

LTF Series

Operation Manual for Electrical Actuator LTF Series

SMC Corporation

Thank you for your purchase of SMC's electrical actuator, LTF series. This operation manual describes handling and precautions necessary to operate LTF series properly. To avoid unexpected failure by mishandling, this operation manual must be read and understood with care prior to handling.

Precautions for handling of electrical actuator (Be sure to read prior to operation .)

Safety instructions

Prior to handling of electrical actuator (including installation, operation and maintenance), be sure to read this operation manual with care to understand proper handling for electrical actuator. Also, master all safety information and precautions as well as function of electrical actuator through this operation manual, and then keep it available whenever necessary.

The cautions indicated in this operation manual are intended to prevent hazardous situations and/or equipment damage. These instructions indicate the level of potential hazard by labeling "Caution", "Warning", and "Danger".

- ⚠ **Caution** : Operator error could result in injury or equipment damage.
- ⚠ **Warning** : Operator error could result in serious injury or loss of life.
- ⚠ **Danger** : In extremely condition, there is possibility of serious injury or loss of life.

Even the precaution indicated with **Caution** could result in more serious situation than defined above as case may be. Any precaution is important and must be kept to ensure safety.

General

- ⚠ **Danger**
Do not use in the explosive, flammable or corrosive atmosphere and in the place exposed to water splash or near combustible staffs.
Only trained people can perform transfer, installation, piping, wiring, operation and maintenance. Other people could have electrical shock, injury and cause fire during these works.
Never touch electrical actuator during operation, especially for motor, table, lead screw, guide and switch.
Do not perform installation, connection and maintenance during energization. Otherwise, electrical shock could be caused.
Do not give any damage and stress to the cable and also put heavy load on or between the cables. Otherwise, electrical shock could be caused.

- ⚠ **Caution**
Do not perform installation, operation and maintenance without keeping instructions for them which can be understood with careful reading of this operation manual. Otherwise, electrical shock, injury and fire could be cause.
Keep in mind any trouble due to modification by user is out of SMC's warranty and responsibility.
Do not eliminate the name label.
Take care about temperature increase on the area around motor.
(Transfer)
Do not hold the cable for transfer of electrical actuator. Otherwise, damage of electrical actuator or injury could be caused.
(Storage)
Do not store in the place exposed to rain and water drip or atmosphere containing harmful gas or liquid.
Shade direct sunlight and keep specified temperature and humidity range. (5 ~ 40 , 10 ~ 90% no dew condensation.)

Opening of package

- ⚠ **Caution**
Check consistency between ordered and delivered product.
If the wrong product is installed, damage of electrical actuator and injury could be caused.
If the carried work might result in injury or the electrical actuator might have opening possible to have the finger pinched, take appropriate measure such as mounting of protective cover.
Ensure the firm connection which is not loosened for the part to be fixed or liked in electrical actuator.

Installation

- ⚠ **Caution**
Do not give any damage including gouge and flaw to the mounting face of both and table. Also keep parallelism of the mounting face 0.05mm at max. The parallelism over this limit could increase sliding resistance and make proper function unavailable.
The electrical actuator can be used for direct mounting of work within allowable range. However, if the work is equipped with external support and guide, consider connection and alignment between the work and actuator.
The referential mounting face of the actuator is just for mounting of actuator itself and must not be applied for mounting of whole system especially for what has external support and guide separately.
Additionally, the connection should be considered so that it can compensate the deflection which becomes bigger as longer stroke is selected.
Do not install in the place exposed to vibration or impact. Otherwise, the electrical actuator could be damaged.
Do not give repeated bending and tensile force to power line for the motor. Otherwise, the line could be broken.
The electrical actuator itself is not equipped with protective cover. So, put the protective cover not to expose the actuator directly as much as possible.
Fix the work firmly by using four mounting holes on the top of table. Never operate the actuator with the work fixed by only to one side.

Wiring

- Do not apply voltage other than specified in this operation manual to any terminal. The terminal could be broken or damaged.
Do not connect to incorrect terminal.

Operation

- ⚠ **Warning**
Do not operate the electrical actuator out of range specified in this operation manual. Otherwise, malfunction could be caused.
Keep specified combination of actuator and controller. Other combinations could result in fire and breakage.

Maintenance

- ⚠ **Danger**
Do not perform disassembly and repair. Otherwise, fire and electrical shock could be caused.
Prior to maintenance, be sure to check controller is turned off.
When checking, take care about the movement of table due to residual external force.
Never touch internal circuit of controller.
Do not perform maintenance with the actuator operating. If required absolutely, never work in the area the actuator is moving.
When founding any abnormality as the result of maintenance, contact SMC immediately.
- ⚠ **Caution**
Contact SMC prior to any repair. Especially, disassembly could make the actuator unable to operate.

Mounting of electrical actuator

- 1 . **Connection of actuator cable**
1 - 1 . Fig. 1 shows how to connect actuator to controller. For further connection of controller, refer to "Operation Manual for Electrical Actuator Controller LC1 Series"

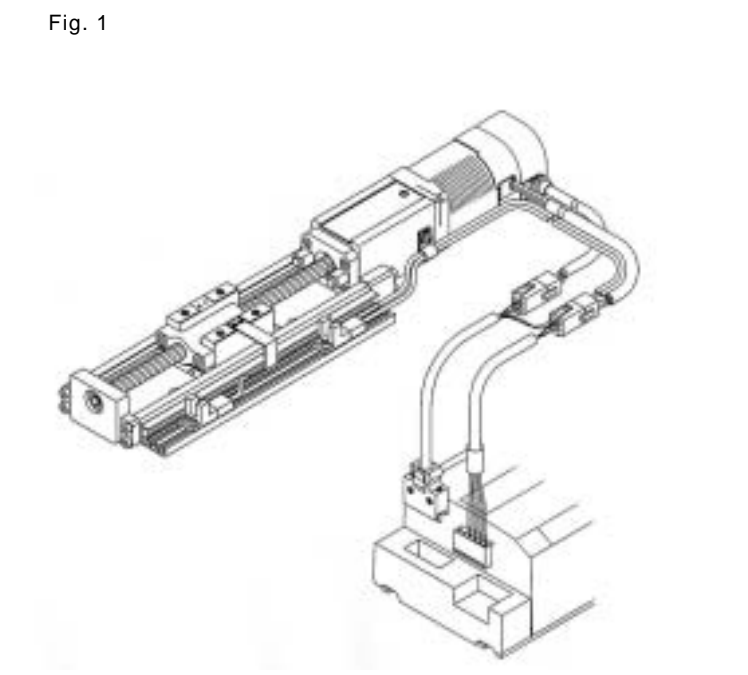

- 2 . **Mounting of actuator**
The actuator is mounted with specific mounting holes.
2 - 1 . LTF6 series
Mounting is performed as shown below with specific mounting holes.

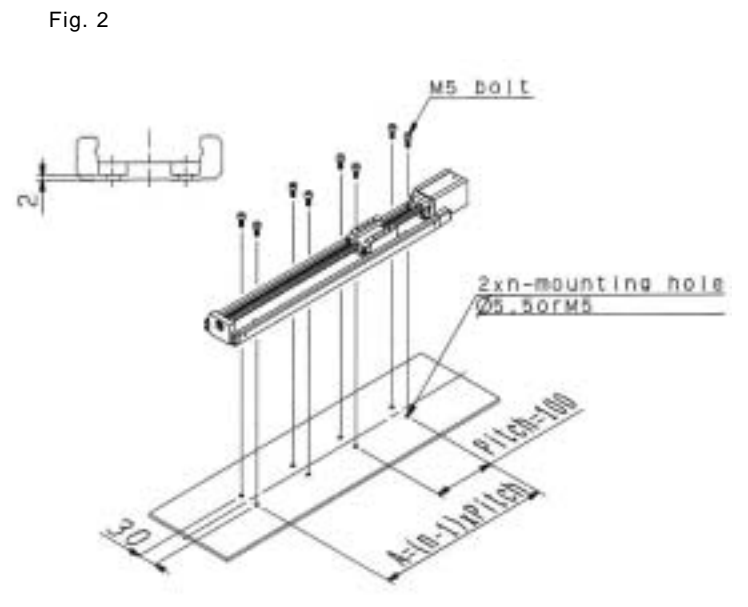

Dimensions

Stroke	n	A	No. of mounting hole
100	2	100	4
200	3	200	6
300	4	300	8
400	5	400	10
500	6	500	12
600	7	600	14

- 2 - 2 . LTF8 series
Mounting is performed as shown below with specific mounting holes.

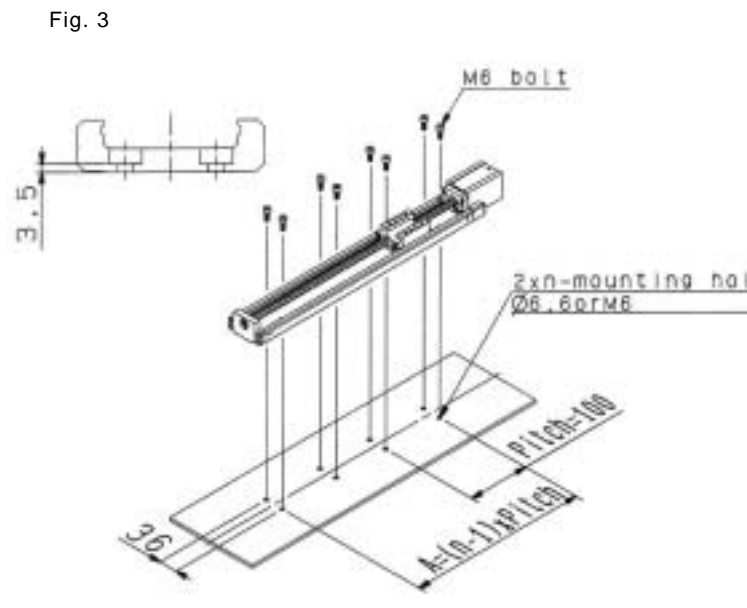

Dimensions

Stroke	n	A	No. of mounting hole
100	2	100	2
200	3	200	4
300	4	300	6
400	5	400	8
500	6	500	10
600	7	600	12
700	8	700	14
800	9	800	16
900	10	900	18
1000	11	1000	20

- 2 - 3 . Referential mounting face
The actuator has referential face for mounting. This face can be used for mounting of the actuator to mating side such as wall, ceiling and floor.

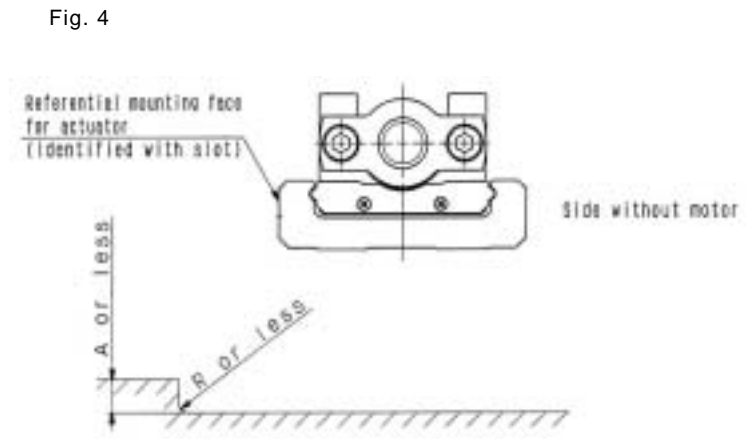

Dimensions (Reference)

Model	R (mm)	A (mm)
LTF6	2	5
LTF8	2.5	6

2 - 4 . Referential mounting face for work

The table of actuator has referential face for mounting of work to the actuator.

Fig. 5

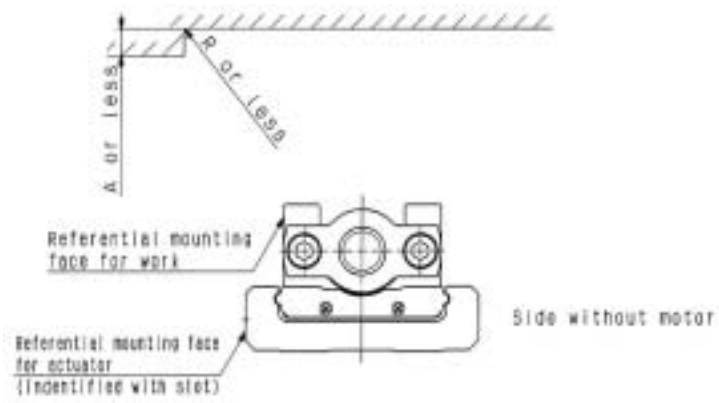

Dimensions (Reference)

Model	R(mm)	A(mm)
LTF6	0.3	2
LTF8	0.3	2

Specifications

1 . Wiring of motor

Fig. 6



Wiring 1 (9 poles)

No.	Color	Part no. of contact
1	U Red	170360-1 or 170364-1
2	V White	
3	W Black	
4	C.G Green	
5	R.SW Output White	
6	F.SW Output White	
7	SW +COM Red	
8	SW -COM Black	
9		

Wiring 2 (15 poles)

No.	Color	Part no. of contact
1	A Blue	170360-1
2	A Blue/Black	
3	B Green	
4	B Green/Black	
5	Z Yellow	
6	Z Yellow/Black	
7	UE Brown	or 170364-1
8	UE Brown/Black	
9	VE Grey	
10	VE Grey/Black	170364-1
11	WE White	
12	WE White/Black	
13	+5V Red	
14	GND Black	
15	SHIELD SHIELD	

2 . Moment of inertia of area in body

Fig. 7

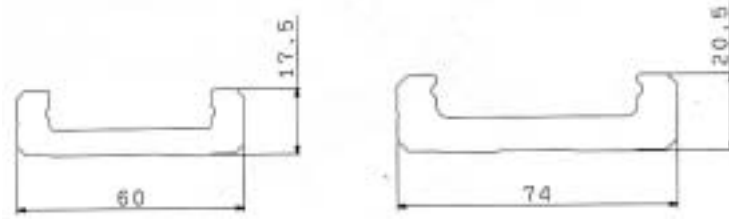

Model	Moment of inertia of area (mm ⁴)	
	I _{xx}	I _{yy}
LTF6	1.2 × 10 ⁴	2.3 × 10 ⁵
LTF8	2.3 × 10 ⁴	5.2 × 10 ⁵

3 . Cross reference between actuator and controller

Each actuator specifies controller to be combined. The table below is cross reference to show the combination. Ensure used combination is correct by using the table to avoid breakage of actuator due to unallowable combination.

Fig. 8

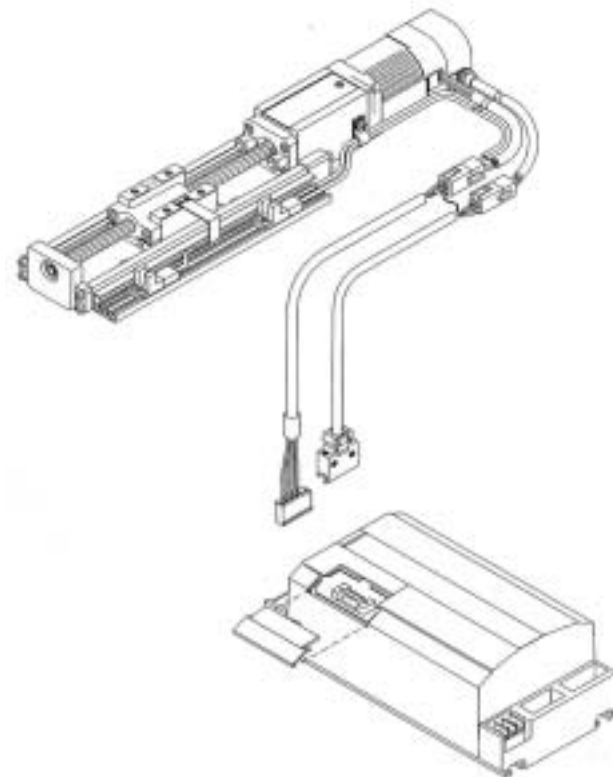

Cross reference

Actuator	Controller
LTF6E1**.*.*.*	LC1-1H2H*1-.*
LTF6E2**.*.*.*	LC1-1H2H*2-.*
LTF8F1**.*.*.*	LC1-1H3H*1-.*
LTF8F2**.*.*.*	LC1-1H3H*2-.*
LTF6E1**.*.*.*K-.*	LC1-1H2V*1-.*
LTF6E2**.*.*.*K-.*	LC1-1H2V*2-.*
LTF8F1**.*.*.*K-.*	LC1-1H3V*1-.*
LTF8F2**.*.*.*K-.*	LC1-1H3V*2-.*

4 . Return to original position

The original position of electrical actuator is determined as follows.

First, the actuator is moved toward original position. After detected by limit switch, the actuator is decelerated. Then, the actuator is moved in opposite direction at creep speed. During movement at creep speed, the actuator is stopped when the first Z phase signal of encoder is outputted, and the position is determined as original position.

Note) The original position is made different due to displacement per revolution of motor. In other words, it depends on difference in lead of ball screw used for the actuator. (If original position needs to be clarified, contact SMC.)

Fig. 9

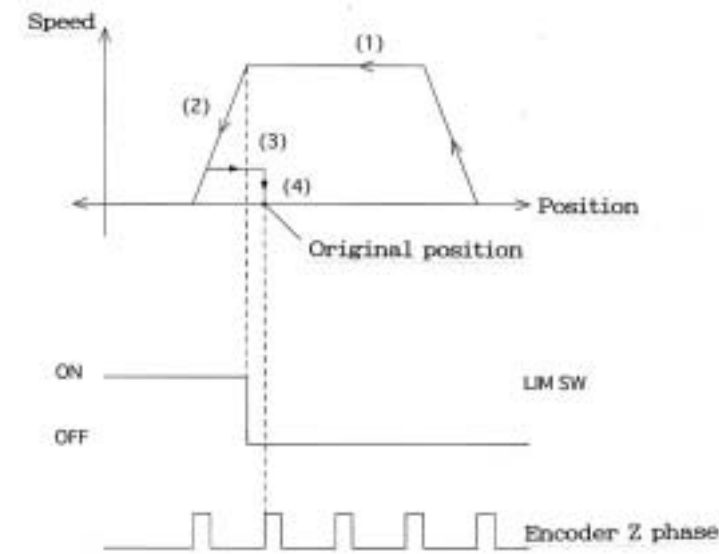

Mounting of switch

1 . How to mount

For mounting of switch, be sure to use screws attached to the actuator. Keep specified tightening torque and apply adhesive specific for screw to prevent looseness.

1 - 1 . Mounting of optical micro sensor

Fig. 10

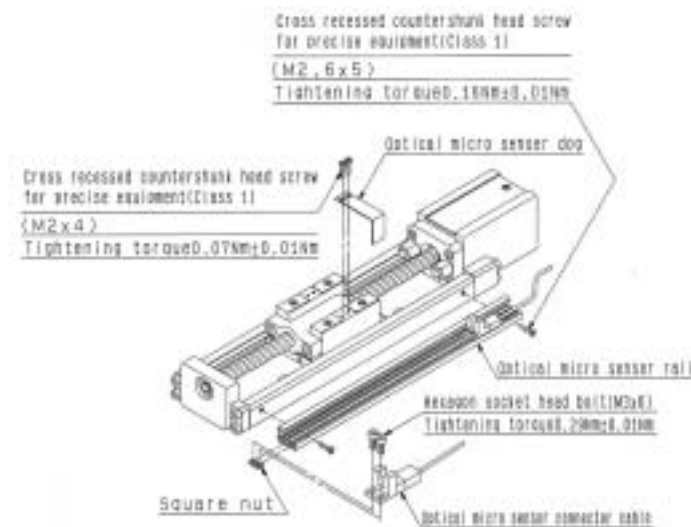

1 - 2 . Mounting of proximity switch

Fig. 11

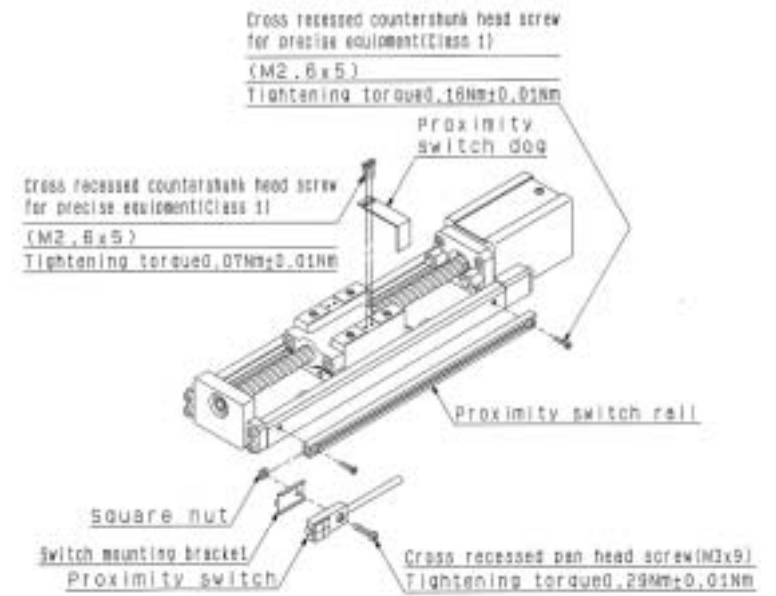

SMC CORPORATION

1-16-4 Shinbashi, Minato-ku, Tokyo 105-0004, JAPAN Tel: 03-3502-2740
Fax: 03-3508-2480 URL: http://www.smcworld.com