



Installation and Maintenance Manual

Zero differential pressure type pilot operated 2 port solenoid valve Series VXZ22/23



EMC Directive 89/336/EEC
 EN61000-6-2:2001: Electromagnetic Compatibility (EMC) - Immunity
 EN61000-6-3:2001: Electromagnetic Compatibility (EMC) - Emission

1 Safety Instructions

- This manual contains essential information for the protection of users and others from possible injury and/or equipment damage.
- Read this manual before using the product, to ensure correct handling, and read the manuals of related apparatus before use.
- Keep this manual in a safe place for future reference.
- These instructions indicate the level of potential hazard by label of "DANGER", "WARNING" or "CAUTION", followed by important safety information which must be carefully followed.
- To ensure safety ISO4414: Pneumatic fluid power and JIS B 8370: Pneumatic system axiom must be observed, along with other relevant safety practices.

⚠ DANGER	In extreme conditions, there is a possibility of serious injury or loss of life.
⚠ WARNING	If instructions are not followed there is a possibility of serious injury or loss of life.
⚠ CAUTION	If instructions are not followed there is a possibility of injury or equipment damage.

⚠ WARNING

- The compatibility of pneumatic equipment is the responsibility of the person who designs the pneumatic system or decides its specifications.**
 Since the products specified here can be used in various operating conditions, their compatibility with the specific pneumatic system must be based on specifications or after analysis and/or tests to meet specific requirements.
- Only trained personnel should operate pneumatically operated machinery and equipment.**
 Compressed air can be dangerous if an operator is unfamiliar with it. Assembly, handling or repair of pneumatic systems should be performed by trained and experienced personnel.
- Do not service machinery/equipment or attempt to remove components until safety is confirmed.**
 - Inspection and maintenance of machinery/equipment should only be performed after confirmation of safe locked-out control positions.
 - When equipment is to be removed, confirm the safety process as mentioned above. Switch off air and electrical supplies and exhaust all residual compressed air in the system.
 - Before machinery/equipment is re-started, ensure all safety measures to prevent sudden movement of cylinders etc. (Supply air into the system gradually to create back pressure, i.e. incorporate a soft-start valve).
- Do not use this product outside of the specifications. Contact SMC if it is to be used in any of the following conditions:**
 - Conditions and environments beyond the given specifications, or if the product is to be used outdoors.
 - Installations in conjunction with atomic energy, railway, air navigation, vehicles, medical equipment, food and beverage, recreation equipment, emergency stop circuits, press applications, or safety equipment.
 - An application which has the possibility of having negative effects on people, property, or animals, requiring special safety analysis.

1 Safety Instructions (continued)

⚠ CAUTION

- Ensure that the air supply system is filtered to 5 microns.

2 Specifications

2.1 Standard Specifications

Valve specifications

Valve construction	Zero differential pressure, pilot operated 2 port diaphragm valve
Withstand pressure (MPa)	5.0
Body material	Brass (C37), Stainless steel
Seal material	NBR, FKM, EPDM
Enclosure	Dusttight, low jetproof (IP65)*
Environment	Location without corrosive or explosive gases

* Electrical entry: Grommet with surge voltage suppressor (GS) has a rating of IP40

Coil specifications

Rated voltage	AC (Class B coil, with built in full-wave rectifier)	100 VAC, 200 VAC, 110 VAC, 220 VAC, 230 VAC, 240 VAC, 48 VAC
	AC (Class H coil)	
	DC (Class B coil only)	24 VDC, 12 VDC
Allowable voltage fluctuation	±10% of rated voltage	
Allowable leakage voltage	AC (Class B coil with built in full-wave rectifier)	10% or less of rated voltage
	AC (Class H coil)	20% or less of rated voltage
	DC (Class B coil only)	2% or less of rated voltage
Coil insulation type	Class B, Class H	

2.2 Solenoid coil specifications

DC Specifications (Class B coil only)

Model	Power consumption (W)	Temperature rise (C°) ^{Note 1}
VXZ22	7	45
VXZ23	10.5	60

Note: The value at ambient temperature of 20°C and when the rated voltage is applied.

AC Specifications (Class B coil with built in full-wave rectifier)

Model	Apparent power (VA) ^{Note 2}	Temperature rise (C°) ^{Note 1}
VXZ22	9.5	60
VXZ23	12	65

Note 1) The value at ambient temperature of 20°C and when the rated voltage is applied.

Note 2) There is no difference in the frequency and the inrush and energised apparent power, since a rectifying circuit is used in the AC (Class B coil with built in full-wave rectifier).

AC Specification (Class H coil)

Model	Apparent power (VA)			Temperature rise (C°) ^{Note 1}
	Frequency (Hz)	Inrush	Energized	
VXZ22	50	65	33	100
	60	55	27	95
VXZ23	50	94	50	120
	60	79	41	115

Note) The value at ambient temperature of 20°C and when the rated voltage is applied.

2 Specifications (continued)

2.3 Model/Valve Specifications

For Air

Inert gas

Normally closed (N.C.)

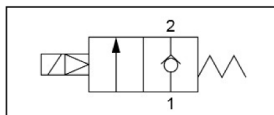

Port size (Nominal size)	Orifice size (mmØ)	Model	Operating pressure differential (MPa)		
			Min	Max	
1/4 (8A)	10	VXZ2230-02	0	1.0	0.7
3/8 (10A)		VXZ2230-03			
1/2 (15A)	VXZ2240-04				
3/4 (20A)	VXZ2350-06				
1 (25A)	VXZ2360-10				

Port size (Nominal size)	Flow characteristics				Maximum system pressure (MPa)	Weight (g)
	C	b	Cv	Effective area (mm²)		
1/4 (8A)	8.5	0.44	2.4	-	1.5	550
3/8 (10A)	11.0	0.42	2.8	-		760
1/2 (15A)	23.0	0.34	6.0	-		1300
3/4 (20A)	38.0	0.20	9.5	-		1480
1 (25A)	-	-	-	215		

Note) Weight of grommet type. Add 10g for conduit type, 30g for DIN terminal type, 60g for conduit terminal type respectively.

Normally open (N.O.)

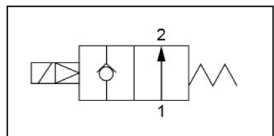

Port size (Nominal size)	Orifice size (mmØ)	Model	Operating pressure differential (MPa)		
			Min	Max	
1/4 (8A)	10	VXZ2232-02	0	0.7	0.6
3/8 (10A)		VXZ2232-03			
1/2 (15A)	VXZ2242-04				
3/4 (20A)	VXZ2352-06				
1 (25A)	VXZ2362-10				

Port size (Nominal size)	Flow characteristics				Maximum system pressure (MPa)	Weight (g)
	C	b	Cv	Effective area (mm²)		
1/4 (8A)	8.5	0.44	2.4	-	1.5	600
3/8 (10A)	11.0	0.42	2.8	-		850
1/2 (15A)	23.0	0.34	6.0	-		1370
3/4 (20A)	38.0	0.20	9.5	-		1550
1 (25A)	-	-	-	215		

Note) Weight of grommet type. Add 10g for conduit type, 30g for DIN terminal type, 60g for conduit terminal type respectively.

Ambient and fluid temperature

Power source	Fluid temperature		Ambient temperature (°C)
	Solenoid valve option symbol		
	NIL, G		
AC/Class B coil	-10 to 60 Note)		-10 to 60
DC	-10 to 60 Note)		-10 to 60

2 Specifications (continued)

For Water

Normally closed (N.C.)

Port size (Nominal size)	Orifice size (mmØ)	Model	Operating pressure differential (MPa)		
			Min	Max	
1/4 (8A)	10	VXZ2230-02	0	1.0	0.7
3/8 (10A)		VXZ2230-03			
1/2 (15A)	VXZ2240-04				
3/4 (20A)	VXZ2350-06				
1 (25A)	VXZ2360-10				

Port size (Nominal size)	Flow characteristics		Maximum system pressure (MPa)	Weight (g)
	AV x 10 ⁻⁶ m ²	Cv converted		
1/4 (8A)	46	1.9	1.5	550
3/8 (10A)	58	2.4		760
1/2 (15A)	130	5.3		1300
3/4 (20A)	220	9.2		1480
1 (25A)	290	12.0		

Note) Weight of grommet type. Add 10g for conduit type, 30g for DIN terminal, 60g for conduit terminal type respectively.

Normally open (N.O.)

Port size (Nominal size)	Orifice size (mmØ)	Model	Operating pressure differential (MPa)		
			Min	Max	
1/4 (8A)	10	VXZ2232-02	0	0.7	0.6
3/8 (10A)		VXZ2232-03			
1/2 (15A)	VXZ2242-04				
3/4 (20A)	VXZ2352-06				
1 (25A)	VXZ2362-10				

Port size (Nominal size)	Flow characteristics		Maximum system pressure (MPa)	Weight (g)
	Av x 10 ⁻⁶ m ²	Cv converted		
1/4 (8A)	46	1.9	1.5	600
3/8 (10A)	58	2.4		850
1/2 (15A)	130	5.3		1370
3/4 (20A)	220	9.2		1550
1 (25A)	290	12.0		

Note) Weight of grommet type. Add 10g for conduit type, 30g for DIN terminal, 60g for conduit terminal type respectively.

Ambient and fluid temperature

Power source	Fluid temperature (°C)		Ambient temperature (°C)
	Solenoid valve option symbol		
	NIL, G, L		
AC/Class B coil	1 to 60		-10 to 60
AC/Class H coil	-		-10 to 60
DC	1 to 60		-10 to 60

Note) With no freezing

2 Specifications (continued)

For Oil

WARNING

When the fluid is oil.

The dynamic viscosity of the fluid must not exceed 50 mm²/s. The special construction of the armature adopted in the built in full-wave rectifier type gives an improvement in OFF response by providing clearance on the absorbed surface when it is switched ON. Select the DC spec. or AC spec. built in full wave rectifier type when the dynamic viscosity is higher than water or when the OFF response is prioritised.

Normally closed (N.C.)

Port size (Nominal size)	Orifice size (mmØ)	Model	Operating pressure differential (MPa)		
			Min	Max	
1/4 (8A)	10	VXZ2230-02	0	0.7	
3/8 (10A)		VXZ2230-03			
1/2 (15A)		VXZ2240-04			
3/4 (20A)		VXZ2350-06			
1 (25A)	25	VXZ2360-10			

Port size (Nominal size)	Flow characteristics		Maximum system pressure (MPa)	Weight (g)
	AV x 10 ⁻⁶ m ²	Cv converted		
1/4 (8A)	46	1.9	1.5	550
3/8 (10A)	58	2.4		760
1/2 (15A)	130	5.3		1300
3/4 (20A)	220	9.2		1480
1 (25A)	290	12.0		

Note) Weight of grommet type. Add 10g for conduit type, 30g for DIN terminal, 60g for conduit terminal type respectively.

Normally open (N.O.)

Port size (Nominal size)	Orifice size (mmØ)	Model	Operating pressure differential (MPa)		
			Min	Max	
1/4 (8A)	10	VXZ2232-02	0	0.7	
3/8 (10A)		VXZ2232-03			
1/2 (15A)		VXZ2242-04			
3/4 (20A)		VXZ2352-06			
1 (25A)	25	VXZ2362-10			

Port size (Nominal size)	Flow characteristics		Maximum system pressure (MPa)	Weight (g)
	AV x 10 ⁻⁶ m ²	Cv converted		
1/4 (8A)	46	1.9	1.5	600
3/8 (10A)	58	2.4		850
1/2 (15A)	130	5.3		1370
3/4 (20A)	220	9.2		1550
1 (25A)	290	12.0		

Note) Weight of grommet type. Add 10g for conduit type, 30g for DIN terminal, 60g for conduit terminal type respectively.

Ambient and fluid temperature

Power source	Fluid temperature (°C)		Ambient temperature (°C)
	Solenoid valve option symbol		
	A, H	D, N	
AC/Class B coil	-5 to 60	-	-10 to 60
AC/Class H coil	-	-5 to 100	-10 to 60
DC	-5 to 60	-	-10 to 60

Note) Dynamic viscosity: 50mm²/s or less

3 Installation

WARNING

Ensure all air and power supplies are ISOLATED before commencing installation. Do not install these valves in explosive atmospheres. If a valve is exposed to oil and/or water droplets, ensure that it is protected. If it is intended to energise a valve for an extended period of time please consult SMC.

This valve is NOT intended to be used as a 'dump' valve.

3.1 Construction

Normally closed (N.C.)

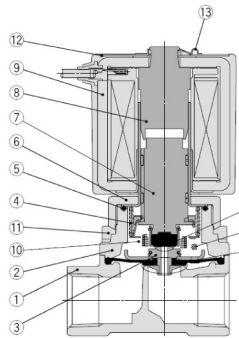

Working principles

<Valve opened - when there is pressure>
When the coil 9 is energized, the armature assembly 7 is attracted into the core of the tube assembly 8 and the pilot valve A is opened.

When the pilot valve is opened and the pressure inside the pilot chamber B decreases, resulting in the pressure difference from the inlet pressure. Then the diaphragm assembly 3 is lifted and the main valve C is opened.

<Valve opened - when there is no pressure or under low minute pressure>
The armature assembly 7 and the diaphragm assembly 3 are connected to each other with the lift spring 10. When the armature assembly is attracted, the diaphragm assembly is pulled up and the main valve C is opened.

<Valve closed>

When the coil 9 is de-energized, the armature assembly 7 returns by the reacting force of the return spring 4 and the pilot valve A is closed.

When the pilot valve is closed, the pressure inside the pilot chamber B increases, resulting in the pressure difference from the inlet pressure is lost and the main valve C closes.

No.	Description	Material	
		Body material brass (C37) specification	Body material stainless steel specifications
1	Body	Brass (C37)	Stainless steel
2	Bonnet	Brass (C37)	Stainless steel
3	Diaphragm assembly	Stainless steel (NBR, FKM, EPDM)	
4	Return spring	Stainless steel	
5	O-ring	(NBR, FKM, EPDM)	
6	Nut	Brass (C37)	Brass (C37), Ni plated
7	Armature assembly	Stainless steel	
8	Tube assembly ^{Note)}	Stainless steel, Cu	Stainless steel, Ag
9	Solenoid coil	-	
10	Lift spring	Stainless steel	
11	Hexagon socket bolt	Stainless steel	
12	Name plate	Aluminium	
13	Clip	SK	

The materials in parentheses are the seal materials.

Note) Cu and Ag are inapplicable to the DC spec and to the AC spec with built in full wave rectifier.

Normally open

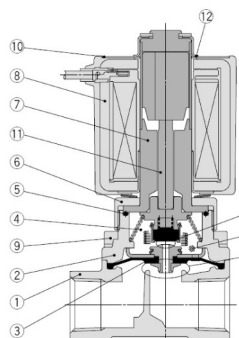

Working principles

<Valve closed>
When the coil 9 is energized, the armature attracted by the core of the tube assembly 8 closes the pilot valve A via the push rod assembly 11. When the pilot valve is closed, the pressure inside the pilot chamber B increases, resulting in the pressure difference from the inlet pressure is lost and the main valve C closes.

3 Installation (continued)

<Valve opened - when there is pressure>

The coil 9 is de-energized, the armature returns by the reacting force of the return spring 4 via the push rod assembly 11 and the pilot valve A is opened. When the pilot valve is opened, the pressure inside the chamber B decreases, resulting in the pressure difference from the inlet pressure. Then the diaphragm assembly 3 is lifted and the main valve C is opened.

<Valve opened - when there is no pressure or under low minute pressure>

The push rod assembly 11 and the diaphragm assembly 3 are connected with each other with the lift spring 10. When the push rod assembly returns, the diaphragm assembly is pulled up and the main valve C is opened.

No.	Description	Material	
		Body material brass (C37) specification	Body material stainless steel specifications
1	Body	Brass (C37)	Stainless steel
2	Bonnet	Brass (C37)	Stainless steel
3	Diaphragm assembly	Stainless steel (NBR, FKM, EPDM)	
4	Return spring	Stainless steel	
5	O-ring	NBR	FKM, EPDM
6	Nut	Brass (C37)	Brass (C37), Ni plated
7	Armature assembly	Stainless steel	
8	Tube assembly ^{Note)}	Stainless steel, Cu	Stainless steel, Ag
9	Solenoid coil	-	
10	Lift spring	Stainless steel	
11	Push rod assembly	PPS, Stainless steel, NBR	Stainless steel, FKM, EPDM
12	Name plate	Aluminium	
13	Cover	Stainless steel	

3.2 Electrical connections

CAUTION

GROMMET

Class H coil: AWG18 Insulator O.D. 2.2mm
Class B coil: AWG20 Insulator O.D. 2.5

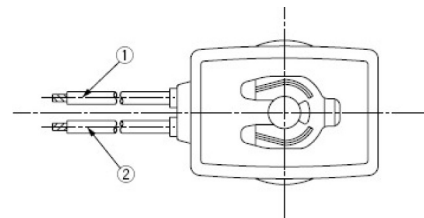

Rated voltage	Lead wire color	
	1	2
DC (class B only)	Black	Red
100 VAC	Blue	Blue
200 VAC	Red	Red
Other AC	Grey	Grey

* There is no polarity

3 Installation (continued)

DIN TERMINAL (Class B only)

Since internal connections are as shown below for the DIN terminal, make connections to the power supply accordingly.

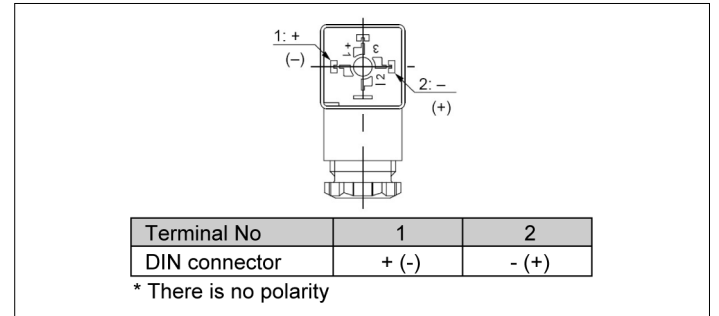

- Use compatible heavy-duty cords with cable O.D of Ø6 to 12mm.
- Use the tightening torques below for each section.

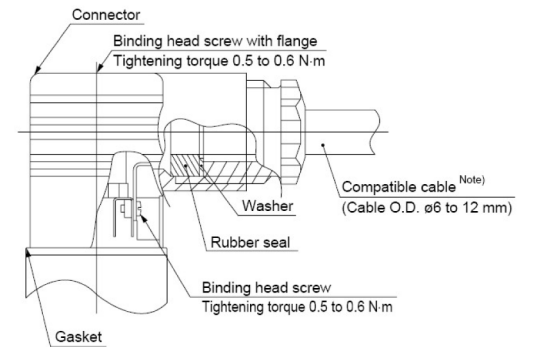

Note) For an outside cable diameter of Ø9 to 12 mm, remove the internal parts of the rubber seal before using.

CONDUIT TERMINAL

In the case of the conduit terminal, make connections according to the marks shown below.

- Use the tightening torques below for each section.
- Properly seal the terminal connection (G1/2) with the special wiring conduit, etc.

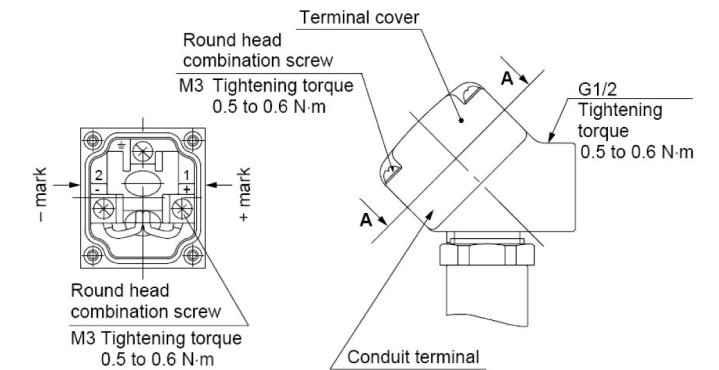

View A-A
(Internal connection diagram)

