



Installation and Maintenance Manual Series V100 3 Port Solenoid Valves

For future reference, please keep this manual in a safe place
This manual should be read in conjunction with the current catalogue.

Safety instructions

These safety instructions are intended to prevent a hazardous situation and/or equipment damage. These instructions indicate the level of potential hazard by label of "Caution", "Warning" or "Danger". To ensure safety, be sure to observe ISO4414^(Note1), JIS B 8370^(Note2) and other safety practices.

Note 1:ISO 4414:Pneumatic fluid power - Recommendations for the application of equipment to transmission and control systems.
Note 2:JIS B 8370:Pneumatic system axiom.

CAUTION: Operator error could result in injury or equipment damage.

WARNING: Operator error could result in serious injury or loss of life.

DANGER: In extreme conditions, there is a possible result of serious injury or loss of life.

WARNING:

1. The compatibility of pneumatic equipment is the responsibility of the person who designs the pneumatic system or decides its specifications.
Since the products specified here are used in various operating conditions, their compatibility for the specific pneumatic system must be based on specifications or after analysis and/or tests to meet your specific requirements.

CAUTION:

Ensure that the air supply system is filtered to 5 micron.

Type of actuation	Model	Type	Operating pressure range MPa	Vacuum application MPa	
				1 port	3 port
N.C.	V114	Standard	0~0.7	-100kPa~0.6	-100kPa~0
N.C.	V114A	Large flow capacity	0~0.7	-100kPa~0.6	-100kPa~0
N.O.	V124	Standard	0~0.7	-100kPa~0	-100kPa~0.6
N.O.	V124A	Large flow capacity	0~0.7	-100kPa~0	-100kPa~0.6

Note 1) In case of V124 and V124A, supply air to "3" port, "1" port will be the exhaust port.

Note 2) Value for DC.

	1→2			2→3		
	C[dm ³ /(s.bar)]	b	Cv	C[dm ³ /(s.bar)]	b	Cv
V114/V124	0.037/0.054	0.11/0.35	0.008/0.015	0.054/0.037	0.35/0.11	0.015/0.008
V114A/V124A	0.076/0.099	0.070/0.23	0.016/0.024	0.099/0.076	0.23/0.070	0.024/0.016

Specifications

Fluid	Air
Ambient and fluid temperature C	-10~Max. 50 C
Note 1) Response time ms	ON: 5ms or less/OFF: 4ms or less
Max. operating frequency Hz	20 Hz
Manual override	Non-locking type, locking slotted type
Lubrication	Non required
Mounting position	Free
Note 2) Impact/Vibration resistance m/s ²	150/30
Enclosure	Dust proof IP40

Note 1) According to dynamic performance test JIS B8374-1981

(Coil temperature 20 C, at rated voltage, without surge voltage suppressor. Except power saving type.)

Note 2) **Impact resistance.** There should be no malfunction of the valve after testing, using a drop impact tester along the valve axis and at right-angles to the valve and armature.

Carry out each test with the valve energised and de-energised. (Value at the initial stage)

Vibration resistance. There should be no malfunction of the valve after testing, using an 8,3 to 2000 Hz sweep along the valve axis and at right-angles to the valve and armature.

Carry out each test with the valve energised and de-energised. (Value at the initial stage)

Solenoid Specifications

Note) At rated voltage

Series	V114/V124	V114A/V124A
Electrical entry	Grommet (G) (H), L type plug connector(L), M type plug connector(M), M8 connector(W)	Grommet (G) (H), L type plug connector(L), M type plug connector(M), M8 connector(W)
Coil rated voltage V DC	24, 12, 6, 5, 3	
Allowable voltage	±10%	
Note) Power consumption W	0.35 (with light: 0.4W) 0.1(power saving type)	1W (with light: 1.1W)
Surge voltage suppressor	Diode (Non-polar style is ZNR)	
Indicator light	LED	

Manifold specifications

Model	S41 type						
Manifold type	Single base style, B mount						
P(SUP)/R(EXH) Type	Common SUP/ Common EXH						
Valves stations	2 to 20 stations						
A porting	Location	Base					
	Direction	Side					
Port size	1, 2, 3 port M5*0.8						
		1→2			2→3		
		C[dm ³ /(s.bar)]	b	Cv	C[dm ³ /(s.bar)]	b	Cv
	V114/V124	0.032/0.050	0.13/0.26	0.0072/0.012	0.050/0.032	0.26/0.13	0.012/0.0072
V114A/V124A	0.070/0.085	0.10/0.16	0.016/0.020	0.085/0.070	0.16/0.10	0.020/0.016	

WARNING:
Operation of Manual Override (Fig.1)

Use caution since manual override operation will operate any connected actuators.

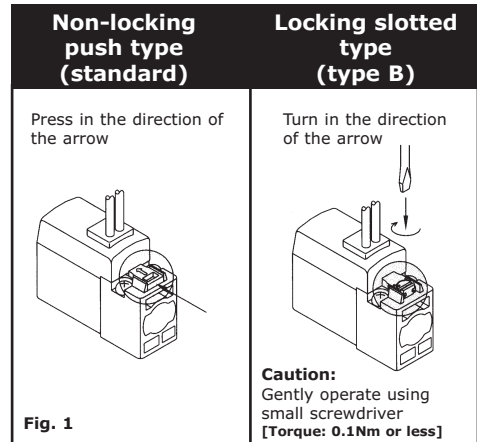

CAUTION:
How to use Plug connector (Fig.2)
Insertion/Removal of Connector

Insertion - Push the connector straight on the pins of the solenoid, making sure the lip of the lever securely "locks" into the groove of the solenoid cover.
Removal - Press the lever against the connector housing and pull it outward from the solenoid.

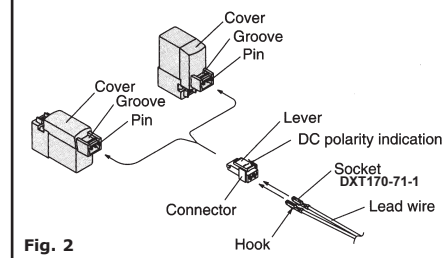

Gasket Assembly (Fig.4)

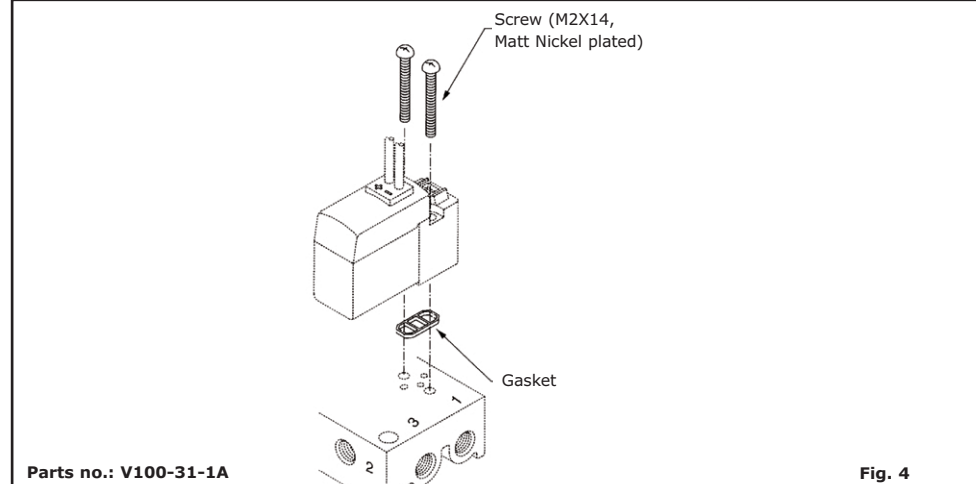

Surge Voltage Suppressor (Fig.6)

(For DC)
Grommet, L and M type plug connector, M8 connector

Standard style with polarity with surge voltage suppressor (S)

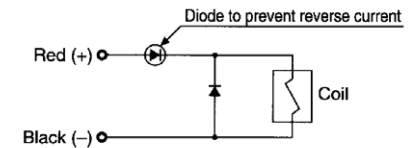

Indicator light and surge voltage suppressor (Z)

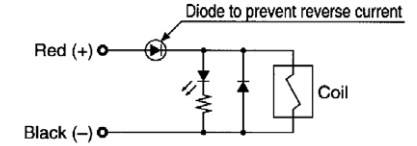

Non-polar style with surge voltage suppressor (R)

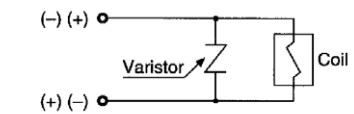

Indicator light and surge voltage suppressor (U)

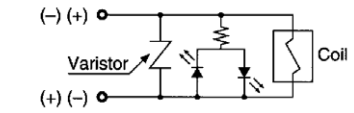

- please correctly connect the lead wires to +(positive) and -(negative) indications on the connector.
- For DC voltages other than 12,24 incorrect wiring will cause damage to the surge voltage suppressor circuit. (Wrong polarity will cause trouble).
- Solenoids, whose lead wires have been pre-wired, are positive side red and negative side black.

With energy saving circuit (except M8 connector)

When it saves the energy while holding, consumption energy is lower by 1/4 approximately in comparison with standard products. Provided that rated DC24V is applied and energized period >62ms.

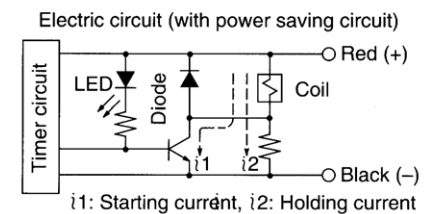

Blanking Plate Assembly (Fig.5)

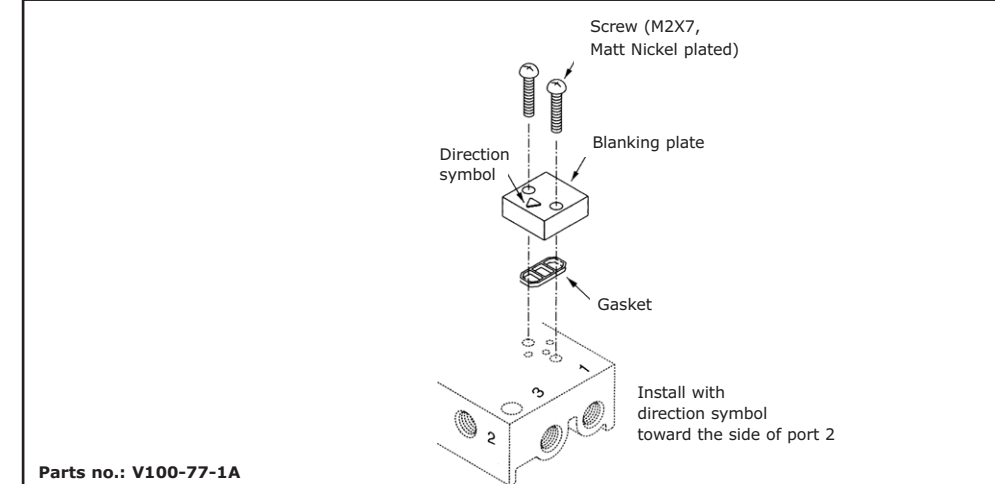

Connector Assembly with Protective cover

Connector assembly with protective cover enhances dust protection.

- Effective in preventing possible short circuit problems due to contaminations in contact with connector section.
- Cover material is chloroprene rubber, which has excellent weather ability and electric insulation properties. However, be careful not to allow contact with cutting oil.
- Round cord provides neat appearance.

Long period continuous energization

When the valves are energized for a long period, coil-generated heat might shorten the life and lower the performance of the solenoid valve. It may also cause connected devices to malfunction. If the application has a long period of continuous energization, or the energized period is longer than non-energized period per day, use a DC specification valve, or a valve with an energy saving circuit. It is also possible to have a shorter energized period by choosing a Normally Open valve. Consult SMC regarding this matter. This countermeasure may not have to be strictly followed, as it depends on the application. In the case of valves installed on a control board, take countermeasures in order to keep the temperature inside the specified range. Manifold mounted valves are close to each other. When valves are energized for a long time and the manifold has more than three stations, the temperature rise must be considered. Be cautious.

⚠ CAUTION

1. Voltage leakage
When C-R device (surge voltage suppressor) is used for the protection of switching device, note that voltage leakage will be increased by passing voltage leakage through C-R device. Suppressor residual voltage leakage should be as follows:

DC coil : 3% or less of rated voltage

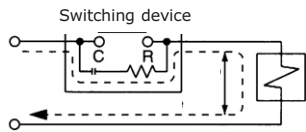

2. Surge voltage suppressor
If a surge protection circuit contains non-ordinary diodes such as Zener diodes or Varistor, a residual voltage that is in proportion to the protective elements and the rated voltage will remain. Therefore, give consideration to surge voltage protection of the controller. In the case of diodes, the residual voltage is approximately 1V.
3. Use in low temperature environments
Valve use is possible at extreme temperature, up to -10°C.
Take appropriate measures to avoid freezing of drainage, moisture etc.
4. Mounting direction. All mounting posture are available.

Wiring

⚠ CAUTION

Polarity

When DC power is connected to a solenoid valve equipped with light and/or surge voltage suppressor, check for polarity indications.

For polarity indications.

No diode to protect polarity:

If polarity connection is wrong, the diode in the valve or switching device at control equipment or power supply may be damaged.

With diode to protect polarity:

If polarity connection is wrong, the valve does not switch.

Low Temperature Application

May be used down to -10°C if the air is sufficiently free of moisture. Please use an appropriate dryer to ensure dry air preventing the valve from freezing.

Piping

⚠ CAUTION

Tightening torques

When installing fittings etc., follow given torque level given below.

Thread	Appropriate tightening torque N·m
M5	1.5-2

Lubrication

⚠ CAUTION

Lubrication

1. The valve has been lubricated for life at manufacture, and does not require lubrication in service.
2. If a lubricant is used in the system, use turbine oil Class 1, ISO VG32 (no additives). Once lubricant is used in the system, you must continue to lubricate, as the original lubricant applied during manufacturing will be washed away.
3. Contact SMC for recommended turbine oil Class 2, ISO VG32 (with additives).

Supply air

⚠ CAUTION

WARNING

Use clean air

If the compressed air supply includes chemicals, synthetic materials (including organic solvents), salinity, corrosive gas etc., it can lead to damage or malfunction.

CAUTION

Install an air filter

Install an air filter at the upper streamside of the valve. Filtration degree should be 5µm or less.

Environment

⚠ WARNING

1. Do not use in atmosphere where the valve is in direct contact with corrosive gases, chemicals, salt water, water or steam.
2. Do not use in an explosive atmosphere.
3. Do not use in a place subject to heavy vibrations and/or shocks. Check the specifications for each series.
4. The valve should not be exposed to prolonged sunlight. Use a protective cover.
5. Remove emissive heat.
6. If using in atmosphere where there is possible contact with water drop-lets, oil, weld spatter, etc., take suitable preventative measures.
7. When the solenoid valve is mounted in a control panel or its energized for a long time, make sure ambient temperature is within the valve specification range.

Maintenance

⚠ WARNING

1. Maintenance procedures are shown in the operation manual.
If maintenance is not properly done, it may cause malfunction and damage of machine or equipment.
2. Machine maintenance and supply/exhaust of compressed air
When machine is to be serviced, first check for removal of work pieces and run-away of equipment, etc.. Then cut the supply pressure and power, and exhaust compressed air in the system through residual pressure release mechanism.
When the machine is to be released, check first that actuators are in their proper start up positions.
3. Low frequency operation
Valves should be switched at least once every 30 days to avoid malfunction. (Pay attention to air supply)
4. Manual override
When manual override is engaged, connected equipment starts to operate.

To enquire about the product, please contact the following :-

SMC Corporation

ENGLAND	01908-563888	TURKEY	212-2211512
ITALY	02-92711	GERMANY	6103-402-0
HOLLAND	020-5318888	FRANCE	01-64761000
SWITZERLAND	052-34-0022	SWEDEN	08-6030700
SPAIN	945-184100	AUSTRIA	02262-62-280
	902-255255	IRELAND	01-4501822
GREECE	01-3426076	DENMARK	87 38 87 00
FINLAND	09-68 10 21	NORWAY	67 12 90 20
BELGIUM	03-3551464	POLAND	48-22-6131847