



Installation and Maintenance Manual

LXS Series Electric Actuator



Read this manual before using this product.

Safety Instructions for Electric Actuator.

Series: LXS2/5□□-□□□□-□□□□-□

1 SAFETY

For safety and proper operation, read this manual thoroughly before use so as to understand the installation, maintenance and safety checks etc. Make sure that you have a good knowledge of the equipment and all the relevant safety precautions prior to installation.

Keep this Installation and Maintenance Manual handy so that operators can refer to it.

1.1 General recommendation

These safety instructions are intended to prevent a hazardous situation and/or equipment damage. These instructions indicate the level of potential hazard by the following labels.

CAUTION: Operator could result in injury or equipment damage.

WARNING: Operator error could result in serious injury or loss of life.

DANGER: In extreme conditions, there is a possible result of serious injury or loss of life.

Even with the label of CAUTION: some of them may lead to serious results depending on circumstances. Make sure to follow every instruction since they are important for safety.

2 GENERAL

DANGER (In general)

- Avoid the use of products in an explosive atmosphere. It could cause injury and fire.
- Only trained personnel should perform transport, installation, piping, wiring, operation and maintenance. There is a possibility of electric shock, injury and fire.
- Never touch the moving part of actuator while operating.
- Do not work with actuators when the power is on. Make sure to switch power off before starting work. It may lead to electric shock.

CAUTION

- Read thoroughly and follow this manual before installation, operation and maintenance. There is a possibility of electric shock, injury and fire.
- Do not use drivers out of specifications. It may lead to electric shock, injury and damage.
- Do not use damaged drivers and actuators. It may lead to injury and fire.
- Product modification made by customers is not covered by warranty. SMC does not take any responsibility for this.
- Do not remove any plate or label attached to the product.
- Use drivers and actuators as in the specified combination. Fire and failure could occur otherwise.
- Pay attention to the rise in temperature of the driver, motor and peripheral equipment. It may lead to burning.

(Transport)

- Make sure not to drop the product during transport. There is a possibility of injury and damage.
- Do not hold cables during transport. It may lead to failure and injury.
- Follow the instructions to avoid collapse of cargo piles due to overloading.

(Disposal)

- Dispose actuators as general industrial waste.

(Storage)

- Do not keep the product in a place where exposed to rain, water droplets or harmful gases and liquids.
- Store in a place within the specified temperature and humidity range (-20 to 70°C, 10 to 90% without condensation) avoiding direct sunlight.

3 UNPACKING

CAUTION

Confirm that the product you received is what you ordered. Injury and damage may occur if an improper product is installed.

4 INSTALLATION

CAUTION

- Take safety measures such as installation of a protective cover if there is a possibility that operators are exposed to danger of injury by moving work pieces.
- Do not dent and scratch body and table mounting surfaces. Keep the parallelism of mounting surface 0.05mm or less. A loss of parallelism may increase sliding resistance and interfere with full performance.
- When connecting a load having an external support or guide mechanism, design a suitable connection and perform careful alignment. Do not install in a place with vibration and impact. Actuators can perform unpredictably or break in this event.
- Avoid repeated bending and tension force applications on power transmission lines of motor. It may lead to breaking of wire.
- Securely tighten all stationary parts and connected parts of actuator so as to prevent them from becoming loose.

4.1 Mounting

Actuator: Mounting is possible in 3 different directions. Choose the one most suitable for your machinery and work piece.

1. Tapped hole			2. Through hole		
Bolt	Max. tightening torque Nm	Max. screw-in depth lmm	Bolt	Max. tightening torque Nm	Max. screw-in depth lmm
M6x1	7.4	20	M5x0.8	4.4	28

3. T-slot		
Bolt	Max. tightening torque Nm	Max. screw-in depth lmm
M6x1	7.4	10

CAUTION

Use bolts at least 0.5 mm shorter than the maximum screw-in depth so as to prevent them from touching the body.

Work piece

1. Front mount			2. Top mount		
Bolt	Max. tightening torque Nm	Max. screw-in depth lmm	Bolt	Max. tightening torque Nm	Max. screw-in depth lmm
M6x1	7.4	13	M5x0.8	4.4	10

5 WIRING

DANGER

- Use double insulated for power supply.
- Do not apply voltage not specified in this operation manual. It could lead to breakage and damage.
- Do not forcibly bend, pull or pinch power supply cables and motor lead wires. It may lead to electric shock.
- Perform wiring and inspection at least 1 minute after cutting power off. There is a danger of electric shock.
- Connect with power supply cables referring to the schematics in this manual. Electric shock and fire may occur otherwise.
- For an emergency stop switch, use one that secures immediate disconnection and isolation of the power supply.

CAUTION

- Do not measure the insulation resistance and withstand voltage. It may lead to breakage.
- Take the following measures against malfunction from noise.
 - Place a line filter in the power supply line to reject noise.
 - Separate signal lines from intense electric field like motor lines and power transmission lines as far as possible so as not to be affected by noise.
 - For inductive load such as solenoid valves and relays, make sure to implement measures against load surge.
- Properly connect to ground using PE (Protective Earth) terminals located on the actuator table and body.

5.1 Home position switch

Power supply voltage	5 to 24VDC ±10%	Ripple (P-P)	10% or less
Current consumption	35mA or less		
Control output	5 to 24VDC		
	Load current (Ic)	100mA	Residual voltage 0.8V or less
	Load current (Ic)	40mA	Residual voltage 0.4V or less

Lead line

Brown	5~24V
White	L
Black	Output
Blue	0V

Output level circuit

Operating condition of output transistor	ON when light enters	ON when light is blocked
Output circuit		
Time chart	("L" and "+" shorted) Light enters: Light blocked: Lighted indicator light (Red): Light ON: Light Off: Output Transistor: ON: OFF: Load 1 (Relay): Operate: Return: Load 2: H: L:	("L" and "+" open) Light enters: Light blocked: Lighted indicator light (Red): Light ON: Light Off: Output Transistor: ON: OFF: Load 1 (Relay): Operate: Return: Load 2: H: L:

Precautions

- Do not operate switches beyond the rated voltage limit. Burst and damage may occur if voltage out of the specified range is applied.
- Avoid faulty wiring such as an error in the polarity of power supply. It may lead to burst and damage.
- Do not short circuit the load. (Do not connect the load to power supply.) It may lead to burst and damage.
- Take the following measures for the use of a commercial switching regulator.
 - Connect with 0V line of power supply just before the sensor or through a capacitor (0.47(μF approximately) to lower the impedance of mounting frames around the sensor and keep out noise from induction.
 - Connect noise filter terminals (intermediate terminal or ACG) of switching power supply with power supply chassis (FG) and 0V line.
- When there is a possibility of a power line surge, connect with a zener diode (30 to 35 V) and a capacitor (0.1 to 1 μ.F), etc. depending on the operating environment. Make sure that surge is eliminated before use.
- If high pressure line, power transmission line and photo micro sensor are in the same piping or in a duct, induction could cause malfunction or damage. Provide separate wiring or piping for them.

Always connect with a reverse voltage suppression diode when driving small induction load such as relays.

5.2 Motor Brake

Basic specifications
 Type: De-energized operation
 Static torque: 0.3 Nm
 Rated voltage: 24VDC± 5%
 Power consumption: 2W (at 75°C)

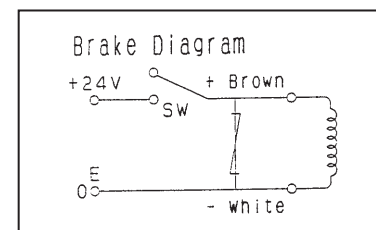

Precautions for use

Motor brake works while de-energized. 24VDC is required to unlock it. Depending on how the actuator (Series LX) with motor brake is wired, timing of the stop is delayed and brake may not work. Refer to the wiring example below and carefully install wiring. Provide a double circuitry so that a circuit where brake operates can be controlled by an external emergency stop.

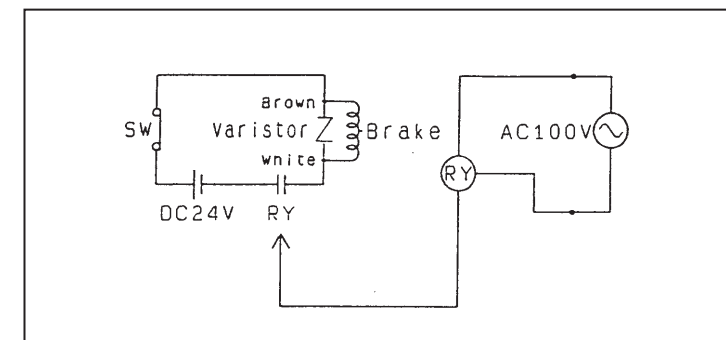

6 OPERATION

WARNING

- Never access or touch terminals and switches while energized. It may lead to electric shock.
- Never touch any moving part of the actuator when it is powered up or operating. This may lead to injury.
- Ensure not to input sudden large performance or parameter changes during the operation cycle. These sudden or large changes can lead to injury.
- Provide an emergency stop circuit externally to stop the operation immediately and cut power off.
- Confirm that no control signal is on before deactivating the emergency stop. Actuators may go out of control and it may lead to injury.
- Brake mechanism of actuator with electro-magnetic brake does not provide secure fixing of load. Do not use it as a safety brake. Take safety measures separately. Injury and breakage may occur otherwise.
- The product performs unpredictably with larger loads than specified or improper setting of speed and acceleration. Erratic movement may lead to injury.

CAUTION

- Do not touch the driver radiator and motor for some time after power has been disconnected, as they heat up when energized. It may lead to a burn.
- Immediately stop the operation in the event of failure. There is a possibility of electric shock, injury and fire.
- Never make an immoderate adjustment and change because it brings unstable operation. It may cause injury.
- Do not access machinery after momentary failure as it may suddenly restart when power supply has recovered. Also, design a machine that secures operators' safety even if it restarts.
- Confirm that specification of power supply is normal. It could lead to failure.
- Check the rotating direction before connecting with other devices. It may cause injury and damage.
- Confirm the setting of drivers and actuators before starting the operation. It may lead to burnout and fire.

7 DUTY RATIO

When using a stepper motor, the motor surface temperature must be kept under 100°C. To achieve this it is advisable to operate the actuator at less than 50% duty ratio independent of the payload.

*Duty ratio: ratio of actuator operating time and suspended time in a cycle. It is calculated by the formula below.

Duty ratio=(operating time / (Operating time + Suspended time)) X100

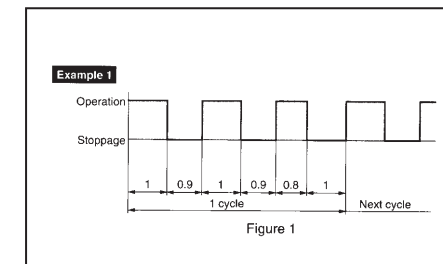

Duty ratio = $\frac{(1+1+0.8)}{(1+0.9+1+0.9+0.8+1)} \times 100 = 50\%$ ∴ Possible to use

8 MAINTENANCE

⚠ DANGER

- Do not overhaul the product. It could lead to fire and electric shock.
- Check the voltage using a tester more than 1 minute after power-off in case of wiring and inspection. There is a possibility of getting electric shock.

⚠ CAUTION

- Ask SMC for repair. The product may become inoperable once disassembled.

9 SPECIFICATIONS

Model	LXSH2SA	LXSH2SB	LXSH2BC	LXSH2BD
Stroke (mm)	50, 75, 100, 125, 150			
Motor	2 phase stepping motor (2.0 A/phase)			
Lead screw	Ø8 Lead 6mm	Ø8 Lead 12mm	Ø8 Lead 2mm	Ø8 Lead 5mm
Work load (kg)*1	9(4) horizontal 4(4) vertical	4.5(4) horizontal 2(2) vertical	10(4) horizontal 6(4) vertical	10(4) horizontal 5(4) vertical
Speed (mm/s)	100	200	30	80
Positioning repeatability (mm)	±0.05		±0.03	
Ambient temperature (°C)	5 to 40 (No condensation)			

*1: Keep the work load within the bracket () value when mounting a work piece to the end plate.

Model	LXSH5SA	LXSH5SB	LXSH5BC	LXSH5BD
Stroke (mm)	50, 75, 100, 125, 150			
Motor	5 phase stepping motor (0.75 A/phase*)			
Lead screw	Ø8 Lead 6mm	Ø8 Lead 12mm	Ø8 Lead 2mm	Ø8 Lead 5mm
Work load (kg)*1	6(4) horizontal 2(2) vertical	3(3) horizontal 1(1) vertical	10(4) horizontal (4) vertical	10(4)horizontal 5(4) vertical
Speed (mm/s)	100	200	30	80
Positioning repeatability (mm)	±0.05		±0.03	
Ambient temperature (°C)	5 to 40 (No condensation)			

*1: Keep the work load within the bracket () value when mounting a work piece to the end plate.

10 CONFORMITY OF LX ELECTRIC ACTUATOR & LC6D DRIVER TO CE DIRECTIVE

- These products do conform to the relevant standards as set out in the EMC Directive 89/336/EEC when used in combination (LC6D series and LX series).
- The Low Voltage Directive is not applicable for these products.
- SMC products are defined as components and thus are intended for incorporation into machinery and assemblies, which are covered by the Machinery Directive 98/37/EC.

10.1 EMC conformity

Although not legally obligated to do so, SMC have had the following set in the "EMC conformity" section tested by a third party organization to ensure that they pass all relevant directives as set out by the EMC Directive 89/336/EEC as in the table below. However the user of the components must take care and responsibility to apply the correct EMC directives to their final machine or assembly into which these components are incorporated."

Conforming standards

Standard	Name	
EN61000-6-2	EN55011	Conducted Emissions
	EN55011	Radiated Emissions
EN61000-6-4	EN61000-4-2	Electrostatic Discharge
	EN61000-4-3	RF Electromagnetic Field
	EN61000-4-4	Fast Transient Burst
	EN61000-4-5	Surge
	EN61000-4-6	Conducted RF Immunity
	EN61000-4-8	Magnetic Immunity
	EN61000-4-11	Voltage Dips & Interruptions

Arrangement of equipment

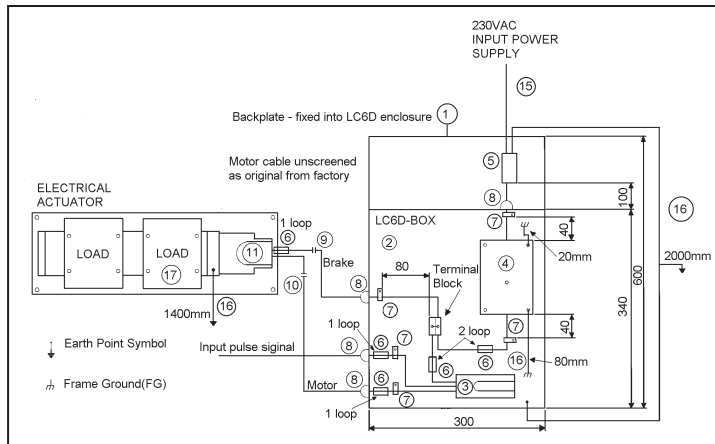

Equipment & parts used

No.	Name	Part No. / Material	Manufacturer
1	Plate (Grounding required.)	Aluminium plate	-
2	Enclose (To be connected with a plate.)	Aluminium case	-
3	Stepping motor driver	Series LC6D	SMC
4	Power supply	ZWS120PPF-24	NEMIC LAMBDA
5	Filter	RF1015-DLC	Rasmi
6	Ferrite core	ESD-SR-25	Tokin
7	P-clip (To ground the shield)	-	-
8	Grommet	-	-
9	D-sub connector (With EMI shield) 15 pins	425-7884, 465-378, 465-384	RS-Component s
10	D-sub connector (With EMI shield) 9 pins	425-7878, 465-356, 465-362	RS-Component s
11	Actuator	Series LX	SMC
12	Motor cable 3 pairs, Shielded heavy-duty cable	3895210	Farnell
13	Signal cable 3 pairs, Shielded heavy-duty cable	3895210	Farnell
14	Motor brake cable Shielded twisted pair cable	140-459	Farnell
15	Power supply cable	-	-
16	Heavy - duty cable	-	-

10.2 Designing instructions

There are some points that require attention to meet the EMC Directives. Refer to the following to design the equipment where these products are built in.

Installation

These products should be installed into an electrical enclosure. Take the following points into consideration when designing an electrical enclosure.

- Choose an enclosure of IP54 (or better).
- Use control panels made of metal (steel or aluminium)
- Securely ground control panels with thick and short electric wires.

Grounding

It is necessary to minimize resistance of grounding parts and contact resistance of the portions connected to ground. Take the following into consideration.

- Use as shorter and thicker wires as possible for grounding cables to keep impedance low.
- Remove paint and insulation coating on contact surfaces to lower the contact resistance.

EMC filter

Set an EMC filter at the supply side of switching power supply. Leave as much space as possible between input and output lines. If they are located too close, the filter may not be very effective due to inducted noise. Also, make the cable between filter output and power supply unit as short as possible.

Motor cable & Signal cable

Use shielded cables. Keep the portion of connector cables, for example, where sheath and shield is stripped as small as possible. Also, ground the shield of each cable just before equipment is connected (LC6D, switching power supply, etc.). Use a P-clip (Fig.9-2-1) and U-clip (Fig.9-2-2) to connect to ground. Grounding is not very effective by soldering wires to a shielded cable (Fig.9-2-3).

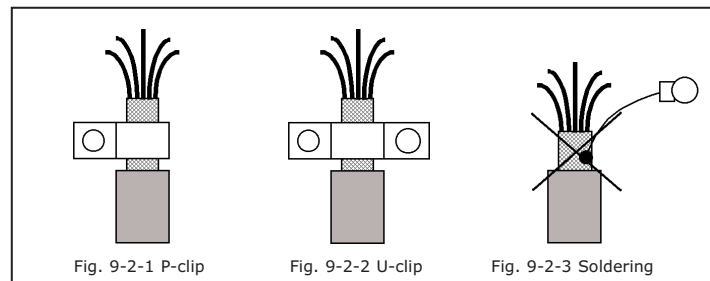

Ferrite core

Place ferrite cores as shown in Fig.1. Provide ferrite cores with loops as many as specified in Fig 9-3-1. ("2 loops" means putting the cable through the ferrite core three times).

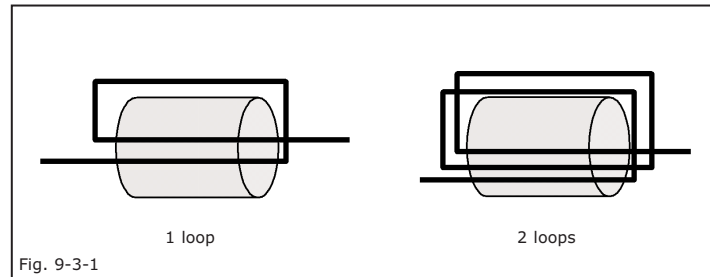

11 EUROPEAN CONTACT LIST

SMC Corporation

Country	Telephone	Country	Telephone
Austria	(43) 2262-62 280	Italy	(39) 02-92711
Belgium	(32) 3-355 1464	Netherlands	(31) 20-531 8888
Czech Republic	(420) 5-414 24611	Norway	(47) 67 12 90 20
Denmark	(45) 70 25 29 00	Poland	(48) 22-548 50 85
Finland	(358) 9-859 580	Portugal	(351) 22 610 89 22
France	(33) 1-64 76 1000	Spain	(34) 945-18 4100
Germany	(49) 6103 4020	Sweden	(46) 8-603 0700
Greece	(30) 1- 342 6076	Switzerland	(41) 52-396 3131
Hungary	(36) 1-371 1343	Turkey	(90) 212 221 1512
Ireland	(351) 1-403 9000	United Kingdom	(44) 1908-56 3888

Websites

SMC Corporation	www.smcworld.com
SMC Europe	www.smceu.com