



# Installation and Maintenance Manual for LG1 Series Electrical Actuator

This manual should be read in conjunction with the current catalogue

## Applicable model numbers:

- LG1□H2182□□□□-□□□□-FO-Q Standard motor
- LG1□H21□2□□□□-□□□□-FO-X10-Q Non standard motor



## 1 SAFETY

For safe and proper operation, read this manual thoroughly before use so as to understand the Installation, maintenance and safety checks etc. Make sure that you have a good knowledge of the equipment and all the relevant safety precautions prior to installation.

Keep this Installation and Maintenance Manual handy so that operators can refer to it.

### 1.1 General recommendation

These safety instructions are intended to prevent a hazardous situation and/or equipment damage.

These instructions indicate the level of potential hazard by a label of "CAUTION", "WARNING" or "DANGER". To ensure safety, please observe ISO 10218 Note 1) and JIS B 8433 Note2) and other safety practices.

- CAUTION:** Operator error could result in injury or equipment damage.
- WARNING:** Operator error could result in serious injury or loss of life.
- DANGER:** In extreme conditions, there is the possibility of serious injury or loss of life.

Note 1) ISO 10218: Manipulating industrial robots.  
 Note 2) JIS B 8433: General rules for robot safety.

## 2 GENERAL

### DANGER (In general)

- Avoid the use of these products in an explosive atmosphere, it could cause injury and fire.
- Do not perform work on the actuators when the power is on. Ensure that the power is switched off before starting work, to avoid risk of electric shock.

### WARNING

- The compatibility of electric actuators is the responsibility of the person who designs the system or decides its specifications.**  
 Since the products specified here are used in various operating conditions, their compatibility for the specific system must be based on specifications or after analysis and/or tests to meet your specific requirements.
- Only trained personnel should operate this equipment.**  
 Electric actuators can be dangerous if an operator is unfamiliar with them. Assembly, handling or repair of systems using electric actuators should be performed by trained and experienced operators.
- Do not service machinery/equipment or attempt to remove components until safe conditions are confirmed.**
  - Inspection and maintenance of machinery/equipment should only be performed after confirmation of safe locked-out control positions.
  - When equipment is to be removed, confirm the safety process as mentioned above, and shut off and isolate the power supply for this equipment.
  - Before machinery/equipment is restarted, confirm that all safety measures are in effect.
- Contact SMC if the product is to be used in any of the following conditions:**
  - Conditions and environments beyond the given specifications, or if the product is to be used outdoors.
  - Installation on equipment in conjunction with atomic energy, medical equipment, food and beverages, or safety equipment.
  - An application, which has the possibility of having negative effects on people, property or animals, requiring special safety analysis.

### CAUTION

- Read thoroughly and follow this manual before installation, operation and maintenance. There is the possibility of electric shock, injury and fire.
- Do not use product out of specifications.
- Do not use damaged drivers and actuators. It may lead to injury and fire.
- Do not remove any plate or label attached to the product.
- Use drivers and actuators in the specified combinations. Fire and failure could occur otherwise.
- Pay attention to the rise in temperature of the driver, motor and peripheral equipment. It may lead to burning.

### (Transport)

- Make sure not to drop the product during transport. There is a possibility of injury and damage.
- Do not hold cables during transport. It may lead to failure and injury.
- Follow the instructions to avoid collapse of cargo piles due to overloading.

### (Disposal)

- The disposal of actuators is as general industrial waste.

### (Storage)

- Do not keep the product in a place where it is exposed to rain, water droplets or harmful gases and liquids.
- Store in a place within the specified temperature and humidity range (-20 to 70°C, 10 to 90% without condensation) avoiding direct sunlight.

## 3 UNPACKING

### CAUTION

Confirm that the product you have received is what you ordered. Injury/damage may occur if an incorrect product is installed.

## 4 INSTALLATION

### CAUTION

- Take safety measures such as the installation of a protective cover if there is the possibility that operators will be exposed to danger of injury by moving parts.
- Do not dent/scratch the body or table mounting surfaces. Keep the parallelism of the mounting surface within 0.05mm. A loss of parallelism may increase the sliding resistance and interfere with overall performance of the actuator.
- When connecting a load having an external support or guide mechanism, design a suitable connection and perform careful alignment.
- Avoid repeated bending and tension forces being applied to power transmission lines of motor cables. It may lead to breaking of wires.
- Securely tighten all stationary parts and connected parts of actuator so as to prevent them from becoming loose.
- Run power and signal cables separately to avoid risk noise of interference.
- Avoid use in the following operating environments.
  - Locations with a lot of debris or dust, or where chips may enter the actuator.
  - Locations where the ambient temperature is outside the range specified. (Refer to specifications)
  - Locations where the ambient humidity is outside the specified range. (Refer to specifications)
  - Locations where corrosive or combustible gases are generated.
  - Locations where strong magnetic or electric fields are generated.
  - Locations where direct vibration or impact shock etc. will be applied to the actuator unit.
  - Locations with a lot of dust and where water or oil splash onto the actuator.
- Perform the following inspections before operating an actuator or controller.
  - Inspection for damage to the actuator/controller power lines.
  - Inspection for looseness of the connectors to each power line and signal line.
  - Inspection for looseness of the actuator/controller mountings.
  - Inspection for abnormal operation of the actuator/controller.
  - Emergency stop buttons are not operated.
  - Implement preventive measures such as a fence enclosure to prevent human entry to the operating area of the actuator/controller
  - Take measures to perform an emergency stop by using a sensor, etc. To prevent human entry into the above mentioned operating area.
- Design Points
  - Do not allow impact or shock load to be applied to the actuator table. (Slider)
  - A protective cover is recommended to minimize the risk of human injury.

## 5 CE DIRECTIVES

### 5.1 Machinery Directive 98/37/EC

SMC Electrical Actuators are defined as components and thus are intended for incorporation into machinery and assemblies, which are covered by the Machinery Directive 98/37/EC (refer to annex II B). CE marking is therefore not applied to Electrical Actuators.

### 5.2 Electromagnetic Compatibility (EMC) Directive 89/336/EEC

SMC use CE marked motors and drivers for the actuators. Please refer to the relevant manuals for installation guidelines.

### 5.3 Low Voltage Directive (LVD) 73/23/EEC

The drivers and motors for these products are in compliance with the LVD. Please refer to the relevant manuals for installation guidelines.

### CAUTION

Always observe installation guidelines and safety instructions of motors and drivers to ensure electrical safety and compliance with the Directives.

## 6 MOUNTING THE ELECTRICAL ACTUATOR

### CAUTION

- Take care that actuator movement does not catch cables.
- Give adequate consideration to the arrangement of wiring, etc., when mounting. If wiring is forced into inappropriate arrangement, this may lead to breaks in the wiring and result in malfunction.
- Ensure that the cables are secured and avoid bending the cables at sharp angles where they enter the actuator, and also be sure that the cables do not move easily.
- Do not use until you verify that the equipment can operate properly.
- Securely tighten all stationary and connected parts of the actuator, so that they will not become loose.
- When attaching a workload, do not apply strong impact shock or a large moment. If an outside force exceeding the allowable moment is applied, this may cause looseness in the guide unit, an increase in sliding resistance or other problems.
- If abnormal heating, smoking or fire occurs in the actuator/controller, shut off the power supply immediately.
- If the electric actuator is repeatedly operated for short strokes (20mm or less) this may cause loss of grease. Therefore operate the actuator for a full stroke once every 40 to 60 cycles.

## 6.1 Reference surfaces

Body reference plane

Reference plane is provided on the actuator body for frame mounting

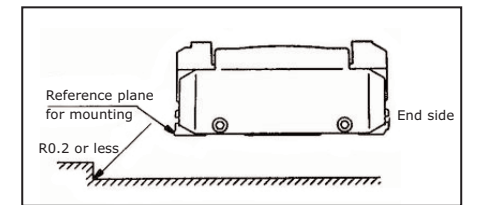

### 6.1.1 Actuator cover

To fix the actuator to the frame by using the body mounting holes, the body cover needs to be removed. Follow the procedure below to remove and mount the body cover.

- Loosen body cover mounting bolts (M3)
- Remove the body cover

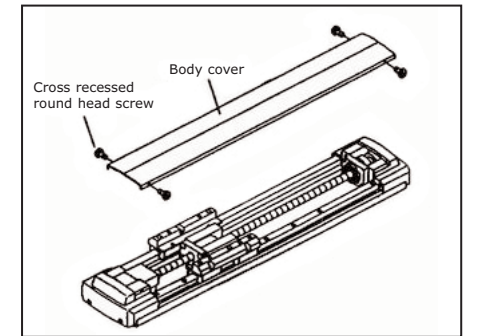

## 6.2 Actuator mounting

### 6.2.1 Mounting Possibilities

### CAUTION

We recommend attaching the actuator onto a sturdy flat plate. Please consider if it is suitable for your application.

### WARNING

The LG actuators must only be mounted in the horizontal position. Never mount the LG actuator vertically.

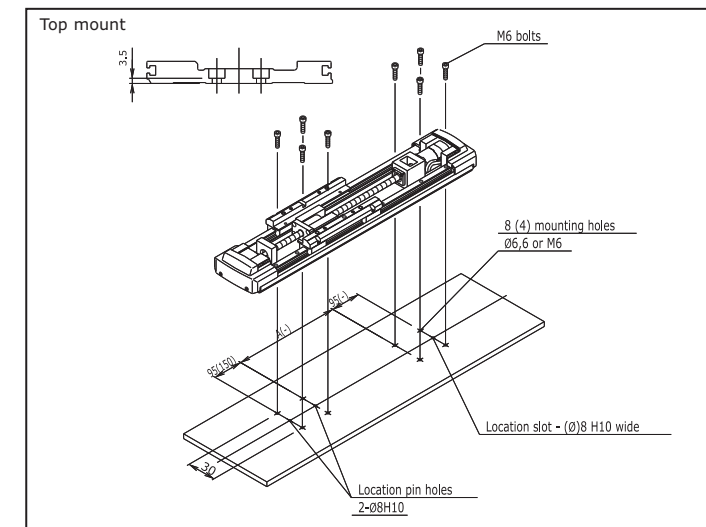

Stroke	A
100	-
200	60
300	160
400	260
500	360
600	460
700	560
800	660
900	760
1000	860
1200	1060

Dimensions inside ( ) are for a 100mm stroke.

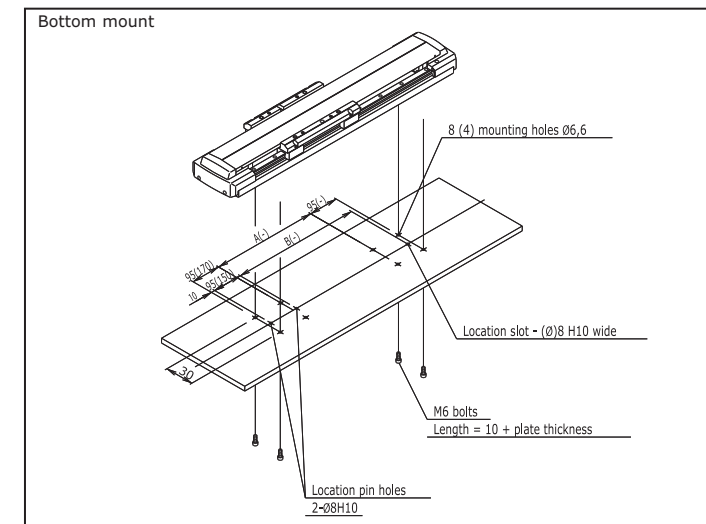

Stroke	A	B
100	-	-
200	80	155
300	180	255
400	280	355
500	380	455
600	480	555
700	580	655
800	680	755
900	780	855
1000	880	955
1200	1080	1155

Dimensions inside ( ) are for a 100mm stroke.

### 6.3 Motor mounting



#### CAUTION:

Refer to relevant motor manual for further information

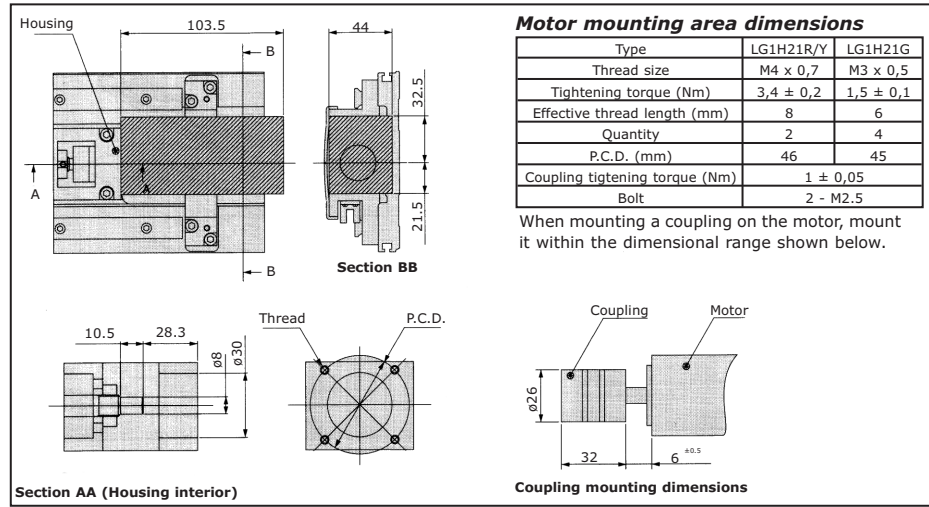

#### Coupling - Mounting precautions



#### DANGER

Provide a safety mechanism

If the product breaks down, the driven part can be completely separated from the driving part. To prevent hazards, be sure to provide a safety mechanism.



#### CAUTION

1) Use our specified bolts and screws only.

The use of bolts or screws other than those specified can damage the bolts, screws or product. Use our specified bolts only.

2) Never use the product with joint slippage.

Slippage at the joint can generate heat during operation, damaging the product and an adverse influence on the machine. Never use the product with joint slippage.

3) Transportation.

In transportation, handle the product carefully to avoid damaging the product. Never handle the product in a way that excessive force is applied to the membrane.

4) Attachment procedures.

The dimension of the attachment shaft should be class h7 or smaller. Do not tighten the clamping bolt until a shaft is inserted into the product.

## 7 ELECTRICAL ACTUATOR STANDARD SPECIFICATIONS



#### WARNING

Never operate the actuator outside the specifications

Stroke			mm	100	200	300	400	500	600	700	800	900	1000	1200
Weight	Horizontal specification	Ball screw	Aluminum alloy frame	5.3	6.1	6.9	7.7	8.5	9.3	10.1	10.9	11.7	12.5	-
			Stainless steel frame	8.3	9.6	10.8	12.0	13.3	14.5	15.8	17.1	18.3	19.6	-
	Slide screw	20 mm Lead	Aluminum alloy frame	5.8	6.7	7.6	8.5	9.4	10.2	11.1	12.0	12.9	13.8	15.9
			Stainless steel frame	9.1	10.5	11.9	13.2	14.6	16.0	17.4	18.8	20.1	21.6	24.9
Operating temperature range			°C	5 to 40 (with no condensation)										
Maximum work load	Horizontal specification	Ball screw	10 mm Lead	30										
			20 mm Lead	-		30								
Maximum speed	Horizontal specification	Ball screw	10 mm Lead	500										
			20 mm Lead	-		1000 930 740 600 500 -								
Rated thrust	Ball screw	10 mm Lead	100W	180										
			20 mm Lead	-		90								
Repeatable positioning accuracy	Ball screw	Rolled	mm	±0.05										
			Ground	±0.02										
Motor output	Horizontal specification	Slide screw	mm	±0.1										
			mm	±0.05										
Encoder			Incremental system											
Feed screw	Horizontal specification	Ball screw	Rolled, Ground	ø15mm, 10mm Lead		-								
			Rolled	-		ø15mm, 20mm Lead								
Guide	Horizontal specification	Slide screw	Rolled	ø20mm, 20mm Lead										
			mm	High rigidity direct acting guide										

## 8 WIRING

### 8.1 General



#### CAUTION

Please refer to the relevant driver manuals for wiring.

### 8.2 Home position switch

#### Rating

Power supply	5 to 24V DC ±10%, Ripple (p-p) 10% or less
Current consumption	35mA or less
Control output	5 to 24V DC load current (Ic) 100mA, Residual voltage 0.8V or less Load current (Ic) 40mA, Residual voltage 0.4V or less
Ambient temperature	Operation: -25 to 55°C (When stored: -30 to 80°C)
Ambient humidity	Operation: 5 to 85%RH (When stored: 5 to 95%RH)
Part no.	EE-SX674 (Omron Corporation)

#### Terminal arrangement

1	Brown	VCC (+)
2	White	L*
3	Black	OUTPUT
4	Blue	GND (OV) (-)

\* Normally ON when light is blocked. However, if the (L) terminal and (+) terminal are shorted, it changes to ON when light enters.

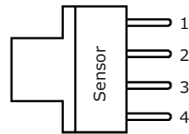

#### Output level circuit

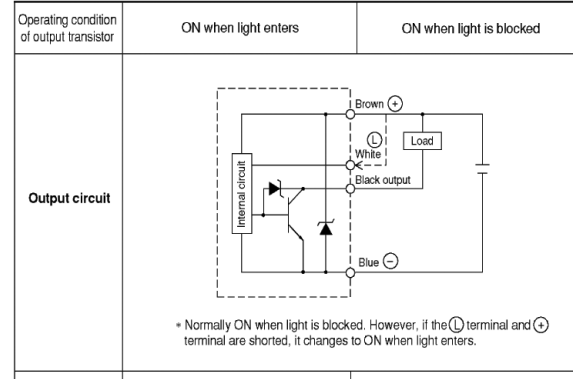

#### Precautions

- Do not operate switches beyond the rated voltage limit. Burst and damage may occur if voltage out of the specified range is applied.
- Avoid faulty wiring such as an error in the polarity of power supply. It may lead to burst and damage.
- Do not short circuit the load. (Do not connect the load to power supply.) It may lead to burst and damage.
- Take the following measures for the use of a commercial switching regulator.

1) Connect with 0V line of power supply just before the sensor or through a capacitor (0.47µF approximately) to lower the impedance of mounting frames around the sensor and keep out noise from induction.

2) Connect noise filter terminals (intermediate terminal or ACG) of switching power supply with power supply chassis (FG) and 0V line.

- When there is a possibility of a power line surge, connect with a zener diode (30 to 35 V) and a capacitor (0.1 to 1 µF), etc. depending on the operating environment. Make sure that surge is eliminated before use.

- If high-pressure line, power transmission line and photo micro sensor are in the same piping or in a duct, induction could cause malfunction or damage. Provide separate wiring or piping for them.

Always connect with a reverse voltage suppression diode when driving small induction load such as relays.

## 9 OPERATION



#### WARNING

- 1) Never access or touch terminals and switches while energized. It may lead to electric shock.
- 2) Never touch any moving part of the actuator when it is powered up or operating. This may lead to injury.



#### CAUTION

- 1) Do not touch the driver radiator and motor for some time after power has been disconnected, as they heat up when energized. It may lead to a burn.
- 2) Immediately stop the operation in the event of failure. There is a possibility of electric shock, injury and fire.
- 3) Check the rotating direction before connecting with other devices. It may cause injury and damage.

## 10 MAINTENANCE INSPECTION



#### DANGER

Do not overhaul the product, it could lead to fire and electric shock.

Check the voltage using a tester, more than 1 minute after the power is turned off before commencing any wiring and inspection.



#### CAUTION

Ask SMC for repair. This product may become inoperable if disassembled.

### 10.1 Maintenance Inspection

It is important to perform regular maintenance inspections of the LG series electrical actuator, to optimise its performance and safe operation. Please familiarize yourself with the information given below, this will enable you to perform the maintenance inspections in a safe and proper manner.

Before performing an inspection it is important to ensure that the power to the controller is switched off/disconnected to avoid the risk of electric shock.

Be extremely careful when handling the actuator, when its power is off/disconnected as there is a danger that the actuators table may unexpectedly move if it is inclined or an external force is inadvertently applied to it.

Do not touch the circuits inside the actuator.

Avoid performing an inspection while the actuator is in operation. If it is necessary to perform the inspection while the actuator is in operation, keep clear of area of movement of the actuator.

If a fault is detected during the inspection, contact your nearest SMC service department as soon as possible.

#### Daily inspection

Perform the following inspections before and after operating the actuator

Inspection Item	Description of Inspection
Actuator Exterior	Check the actuator for scratches or dings. Check for cutting debris, dust, water or other liquids.
Ball Screw Bearing	Check for noise or play.
Guide	Check for abnormal vibration, play and noise.
Motor	Check for overheating.
Cable	Check for damage, cuts, kinks and improper use.

#### Periodic inspection

After 6 months operation or after 1 month of non-operation

Inspection Item	Description of Inspection
Bolts and screws used for mounting the unit	Check for looseness
Ball screw and Linear Guide	After cleaning the threaded portion of the ball screw, manually apply grease to the threads, and move the table back and forth, to spread the grease. Use grease such as Albania No.2 by Showa Shell Oil or Duffney Coronex No.2 by Idemitsu Kosan. Apply the above mentioned grease by hand to the linear guide. Using rubber gloves or rubber finger covers to avoid contamination.
Slide screw and Guide	After cleaning the threaded portion of the slide screw, manually apply grease to the threads, and move the table back and forth, to spread the grease. Use grease order code: LJ1-33M applied at the rate of 10g/100mm. Apply the above mentioned grease by hand to the slide guide. Using rubber gloves or rubber finger covers to avoid contamination.

#### Special Grease - Important note:

Do not use other types of grease, as this may lead to short life or other detrimental conditions occurring during operation of the actuator.

## 11 EUROPEAN CONTACT LIST

#### SMC Corporation

Country	Telephone	Country	Telephone
Austria	(43) 2262-62 280	Italy	(39) 02-92711
Belgium	(32) 3-355 1464	Netherlands	(31) 20-531 8888
Czech Republic	(420) 5-414 24611	Norway	(47) 67 12 90 20
Denmark	(45) 70 25 29 00	Poland	(48) 22-548 50 85
Finland	(358) 9-859 580	Portugal	(351) 22 610 89 22
France	(33) 1-64 76 1000	Spain	(34) 945-18 4100
Germany	(49) 6103 4020	Sweden	(46) 8 603 12 00
Greece	(30) 1- 342 6076	Switzerland	(41) 52-396 3131
Hungary	(36) 23 511 390	Turkey	(90) 212 221 1512
Ireland	(353) 1-403 9000	United Kingdom	(44) 1908-56 3888

#### Websites

SMC Corporation	www.smcworld.com
SMC Europe	www.smceu.com