



Installation and Maintenance Manual

LC6D Series Stepper Motor Driver



Read this manual before using this product.
Safety Instructions for Stepper Motor Driver.

Series: LC6D-□□□AD - P1-X316

1 SAFETY

For safety and proper operation, read this manual thoroughly before use so as to understand the installation, maintenance and safety checks etc. Make sure that you have a good knowledge of the equipment and all the relevant safety precautions prior to installation.

Keep this Installation and Maintenance Manual handy so that operators can refer to it.

1.1 General recommendation

These safety instructions are intended to prevent a hazardous situation and/or equipment damage. These instructions indicate the level of potential hazard by the following labels.

	CAUTION: Operator could result in injury or equipment damage.
	WARNING: Operator error could result in serious injury or loss of life.
	DANGER: In extreme conditions, there is a possible result of serious injury or loss of life.

Even with the label of CAUTION: some of them may lead to serious results depending on circumstances. Make sure to follow every instruction since they are important for safety.

2 GENERAL

DANGER (In general)

- Avoid the use of products in an explosive atmosphere. It could cause injury and fire.
- Only trained personnel should perform transport, installation, piping, wiring, operation and maintenance. There is a possibility of electric shock, injury and fire.
- Never touch the moving part of actuator while operating.
- Do not work with actuators when the power is on. Make sure to switch power off before starting work. It may lead to electric shock.
- Never touch the inside of the driver. It may lead to electric shock.
- Do not damage, apply excessive force to, put heavy weights on and pinch cables. It may lead to electric shock.

CAUTION

- Read thoroughly and follow this manual before installation, operation and maintenance. There is a possibility of electric shock, injury and fire.
- Do not use drivers out of specifications. It may lead to electric shock, injury and damage.
- Do not use damaged drivers and actuators. It may lead to injury and fire.
- Product modification made by customers is not covered by warranty. SMC does not take any responsibility for this.
- Do not remove any plate or label attached to the product.
- Use drivers and actuators as in the specified combination. Fire and failure could occur otherwise.
- Pay attention to the rise in temperature of the driver, motor and peripheral equipment. It may lead to burning.

(Transport)

- Make sure not to drop the product during transport. There is a possibility of injury and damage.
- Do not hold cables during transport. It may lead to failure and injury.
- Follow the instructions to avoid collapse of cargo piles due to overloading.

(Disposal)

- Dispose drivers as general industrial waste.

(Storage)

- Do not keep the product in a place where exposed to rain, water droplets or harmful gases and liquids.
- Store in a place within the specified temperature and humidity range (-20 to 70°C, 10 to 90% without condensation) avoiding direct sunlight.

3 UNPACKING

CAUTION

Confirm that the product you received is what you ordered. Injury and damage may occur if an improper product is installed.

Open the package and check the label to see whether the driver you received is what you ordered.

Contents		Part No.	Quantity
Driver	2 phase	LC6D-220AD-P1-X316	1
	5 phase	LC6D-507AD-P1-X316	
Receptacle		5557-14R	1
Female terminal		5556PBT	14

4 INSTALLATION

CAUTION

- Set in an enclosure where water, oil, carbon, smoke dust does not enter. (IP54 equivalent)
- Do not place obstacles to ventilation around the driver. Abnormal heating may pose a danger as cooling is inhibited.
- Ensure correct mounting. Incorrect mounting direction may cause malfunction.
- Design the driver so as to allow connection and disconnection after installation.
- Prevent inlet/outlet from being blocked and foreign matter from getting into it. It may lead to fire.
- Keep a space of 50mm or more between the body and inner walls of control panel or other equipment. Failure could occur otherwise.
- Prevent screws from hitting the driver body in case of DIN rail mounting. It could cause failure.
- Never install in a place subjected to water splash, corrosives and inflammable gases, and adjacent to combustible materials. It could lead to fire and malfunction.
- Do not step on nor put heavy things on the product. It may lead to injury.
- Avoid strong impact. It could cause malfunction.
- Make sure that the product does not fall during installation. There is a danger of injury and damage.

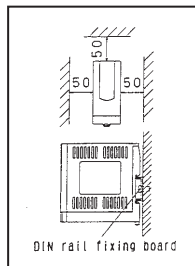

4.1 Actuator type

a. Applicable actuator for LC6D-220AD-P1-X316

Series	Model
LXP (Guide rod type)	LXPB2 □□-□□□□□-□□□□-□
LXS (High rigidity slide table)	LXSH2 □□-□□□□□-□□□□-□

b. Applicable actuator for LC6D-507AD- P1-X316

LXF (Low profile slide table)	LXFH5 □□-□□□□□-□□□□-□
LXP (Guide rod type)	LXPB5 □□-□□□□□-□□□□-□
LXS (High rigidity slide table)	LXSH5 □□-□□□□□-□□□□-□

4.2 Dimensions

- *1 . With DIN rail attached
- *2 . With operation window open

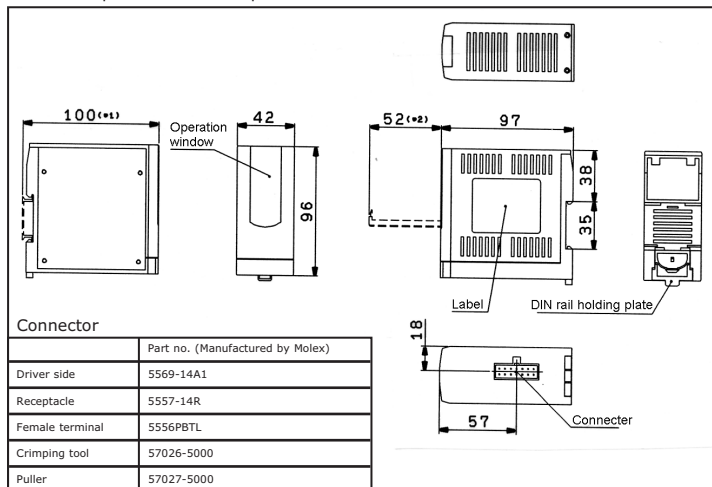

4.3 Mounting

Hook the upper side onto the DIN rail (1) and press the lower side until it is secured to the DIN rail. (2) For removal, insert a flat-blade screwdriver into the pocket (3) and pull it out in the direction of an arrow.

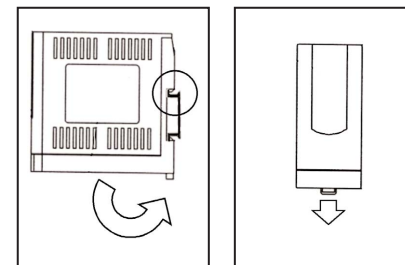

5 WIRING

DANGER

- Use power supply of double insulation.
- Do not apply voltage not specified in this operation manual. It could lead to breakage and damage.
- Do not forcibly bend, pull or pinch power supply cables and motor lead wires. It may lead to electric shock.
- Perform wiring and inspection at least 1 minute after cutting power off. There is a danger of electric shock.
- Connect with power supply cables referring to the schematics in this manual. Electric shock and fire may occur otherwise.
- For an emergency stop switch, use one that secures immediate disconnection and isolation of the power supply.

CAUTION

- Do not measure the insulation resistance and withstand voltage. It may lead to breakage.
- Take the following measures against malfunction from noise.
 - Place a line filter in the power supply line to reject noise.
 - Separate signal lines from intense electric field like motor lines and power transmission lines as far as possible so as not to be affected by noise. Possibility of uncontrolled movement and injury.
 - For inductive load such as solenoid valves and relays, make sure to implement measures against load surge.
- Properly connect to ground using PE (Protective Earth) terminals located on the actuator table and body.

5.1 Electrical Wiring [Connection example with PNP (source) type]

DANGER

LC6D-□□□AD - P1-X316

Power supply over 0.5mm² (AWG18-20), Wiring for motor
 — Wiring for signal over 0.2mm² (AWG18-24)

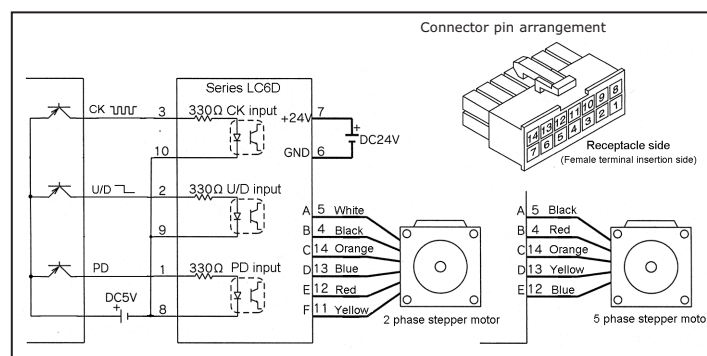

- For signal power of 24VDC (common to Series LC6D)**
Connect an external resistor R (1.3kW 1/2W) to keep the current below 15mA.

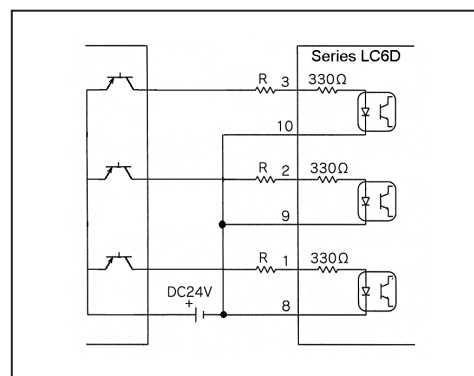

b. Connection example with NPN (sink) type

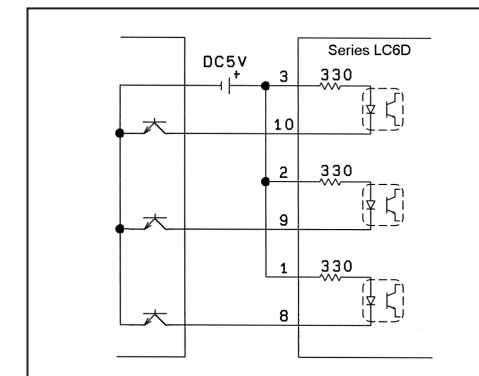

6 OPERATION

WARNING

- Never access or touch terminals and switches while energized. It may lead to electric shock.
- Never touch the rotor of motor during operation. It may lead to injury.
- Do not touch switches with wet hand. It may lead to injury.
- Provide an emergency stop circuit externally to stop the operation immediately and cut power off.
- Confirm that no control signal is on before deactivating the emergency stop. Actuators may go out of control and it may lead to injury.
- Brake mechanism of actuator with electro-magnetic brake does not provide secure fixing of load. Do not use it as a safety brake. Take safety measures separately. Injury and breakage may occur otherwise.
- The product performs unpredictably with larger loads than specified or improper setting of speed and acceleration. Erratic movement may lead to injury.

CAUTION

- Do not touch the driver radiator and motor for some time after power has been disconnected, as they get hot when energized. It may lead to a burn.
- Immediately stop the operation in the event of failure. There is a possibility of electric shock, injury and fire.
- Ensure not to input sudden large performance or parameter changes during the operation cycle. These sudden or large changes can lead to injury.
- Do not access machinery after momentary failure as it may suddenly restart when power supply has recovered. Also, design a machine that secures operators' safety even if it restarts.
- Confirm that specification of power supply is normal. It could lead to failure.
- Check the rotating direction before connecting with other devices. It may cause injury and damage.
- Confirm all settings on the equipment are correct before operation and ensure settings match those specified for the driver and actuator being used. Otherwise failure may occur.
- Ensure driver surface temperature remains below 80°C at all times.

6.1 Input signal

CK input terminal
Upon application of a pulse signal, the actuator moves.

U/D input terminal
Switching input signals changes rotating direction. The actuator moves to end side (CW) with an ON signal and to motor side (CCW) with an OFF signal.

PD input terminal
Upon application of an ON signal, the current carried to the motor is cut (approximately 200ms after the last application of a pulse signal) and the motor is not energized anymore.

6.2 Input signal standard

Pulse height	Level H (ON): 4 to 5.5V	Level L (OFF): 0 to 0.5V
Pulse width	20 μs or more	
Pulse duty	No more than 50%	

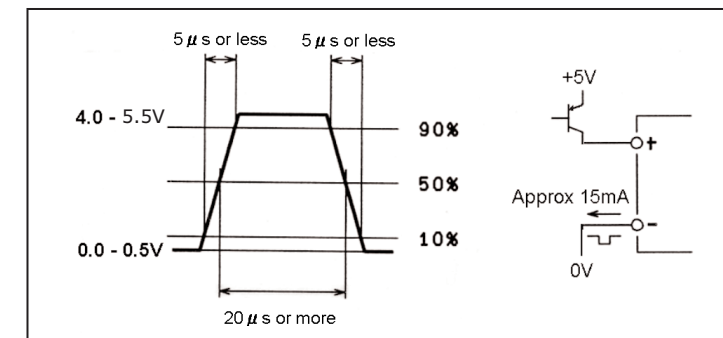

6.3 Functions and Function change-over switch

Where to find a function change-over switch

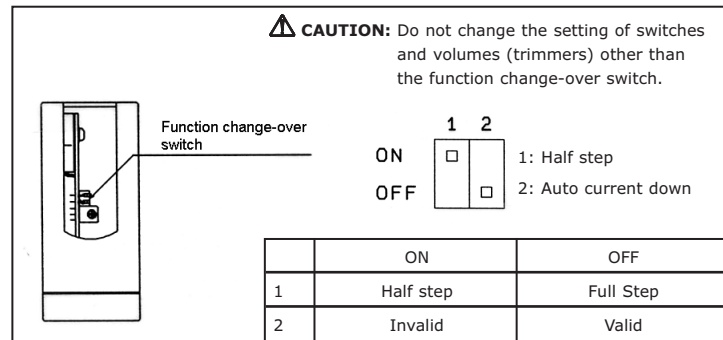

- Switching from half step to full step: Change over the way of energization when needed.

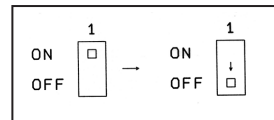

- Deactivating the function of auto current down: Turn on and off the function of auto current down when needed.

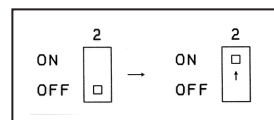

- Auto current down

This is a function that automatically reduces the current almost by half inside the equipment as it stops (approximately 200ms after the last application of a pulse signal). If sufficient torque is required at the time of stop, this function can be deactivated with the function change-over switch.

7 MAINTENANCE

DANGER

- Do not overhaul the product. It could lead to fire and electric shock.
- Check the voltage using a tester more than 1 minute after power-off in case of wiring and inspection. There is a possibility of getting electric shock.

CAUTION

- Ask SMC for repair. The product may become inoperable once disassembled.
- Pay attention to the driver radiator in case of maintenance. It may lead to a burn from high temperature.

Condensers in the power supply line decrease in capacity due to deterioration. To prevent secondary disaster, replacement is recommended approximately every 10 years.

8 ELECTRIC SPECIFICATION

Item	LC6D-220AD-P1-X316	LC6D-507AD-P1-X316
Power supply	24VDC±10% 3.0 A	24VDC±10% 2.5 A
Applicable motor	2 phase stepping motor (2.0 A/phase)	5 phase stepping motor (0.75 A/phase)
Energization	Half step (0.9°/pulse) Full step (1.8°/pulse)	Half step (0.36°/pulse) Full step (0.72°/pulse)
Input signal	Photo coupler input ---- Input impedance 330Ω Input voltage ---- H = 4 to 5.5V _L -0 to 0.5V Input current ---- 15 mA or less	
Function	Auto current down, Power down input	
External connection	Connector	
Weight	0.24 kg	
Ambient temperature	5 to 40°C (No condensation)	
Ambient humidity	35 to 85 % (No condensation)	
Storage temperature	-20 to 70°C (No freezing)	
Storage humidity	10 to 90% (No condensation)	
Vibration proof	Resonance test ----- 10 to 55 Hz, Total amplitude 0.3 mm Regular amplitude test ---- 20 Hz, Total amplitude 1.2 mm Vibration direction ----X, Y, Z 30 min. each	

9 CONFORMITY OF LX ELECTRIC ACTUATOR & LC6D DRIVER TO CE DIRECTIVE

- These products do conform to the relevant standards as set out in the EMC Directive 89/336/EEC
- The Low Voltage Directive is not applicable for these products.
- SMC products are defined as components and thus are intended for incorporation into machinery and assemblies, which are covered by the Machinery Directive 98/37/EC.

9.1 EMC conformity

Although not legally obligated to do so, SMC have had the following set in the "EMC conformity" section tested by a third party organization to ensure that they pass all relevant directives as set out by the EMC Directive 89/336/EEC as in the table below. However the user of the components must take care and responsibility to apply the correct EMC directives to their final machine or assembly into which these components are incorporated."

Conforming standards

Standard	Name	
EN61000-6-2	EN55011	Conducted Emissions
	EN55011	Radiated Emissions
EN61000-6-4	EN61000-4-2	Electrostatic Discharge
	EN61000-4-3	RF Electromagnetic Field
	EN61000-4-4	Fast Transient Burst
	EN61000-4-5	Surge
	EN61000-4-6	Conducted RF Immunity
	EN61000-4-8	Magnetic Immunity
	EN61000-4-11	Voltage Dips & Interruptions

Arrangement of equipment

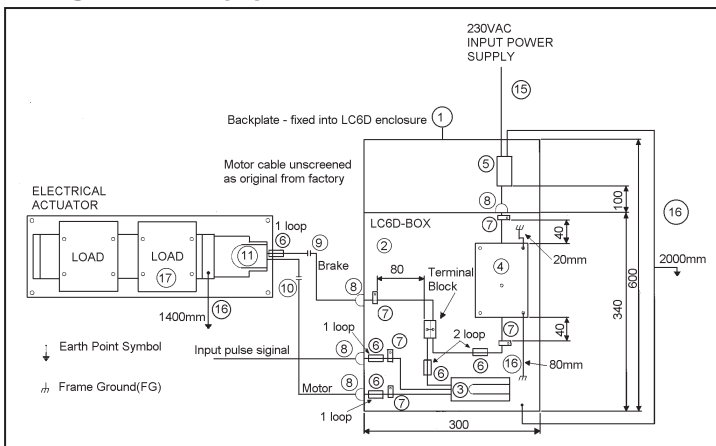

Equipment & parts used

No.	Name	Part No. / Material	Manufacturer
1	Plate (Grounding required.)	Aluminium plate	-
2	Enclose (To be connected with a plate.)	Aluminium case	-
3	Stepping motor driver	Series LC6D	SMC
4	Power supply	ZWS120PPF-24	NEMIC LAMBDA
5	Filter	RF1015-DLC	Rasmi
6	Ferrite core	ESD-SR-25	Tokin
7	P-clip (To ground the shield)	-	-
8	Grommet	-	-
9	D-sub connector (With EMI shield) 15 pins	425-7884, 465-378, 465-384	RS-Component s
10	D-sub connector (With EMI shield) 9 pins	425-7878, 465-356, 465-362	RS-Component s
11	Actuator	Series LX	SMC
12	Motor cable 3 pairs, Shielded heavy-duty cable	3895210	Farnell
13	Signal cable 3 pairs, Shielded heavy-duty cable	3895210	Farnell
14	Motor brake cable Shielded twisted pair cable	140-459	Farnell
15	Power supply cable	-	-
16	Heavy - duty cable	-	-

9.2 Designing instructions

There are some points that require attention to meet the EMC Directives. Refer to the following to design the equipment where these products are built in.

Installation

These products should be installed into an electrical enclosure. Take the following points into consideration when designing an electrical enclosure.

- Choose an enclosure of IP54 (or better).
- Use control panels made of metal (steel or aluminium)
- Securely ground control panels with thick and short electric wires.

Grounding

It is necessary to minimize resistance of grounding parts and contact resistance of the portions connected to ground. Take the following into consideration.

- Use as shorter and thicker wires as possible for grounding cables to keep impedance low.
- Remove paint and insulation coating on contact surfaces to lower the contact resistance.

EMC filter

Set an EMC filter at the supply side of switching power supply. Leave as much space as possible between input and output lines. If they are located too close, the filter may not be very effective due to inducted noise. Also, make the cable between filter output and power supply unit as short as possible.

Motor cable & Signal cable

Use shielded cables. Keep the portion of connector cables, for example, where sheath and shield is stripped as small as possible. Also, ground the shield of each cable just before equipment is connected (LC6D, switching power supply, etc.). Use a P-clip (Fig.9-2-1) and U-clip (Fig.9-2-2) to connect to ground. Grounding is not very effective by soldering wires to a shielded cable (Fig.9-2-3).

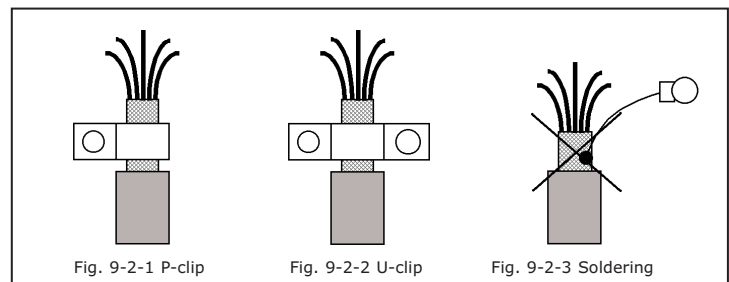

Ferrite core

Place ferrite cores as shown in Fig.1. Provide ferrite cores with loops as many as specified in Fig 9-3-1. ("2 loops" means putting the cable through the ferrite core three times).

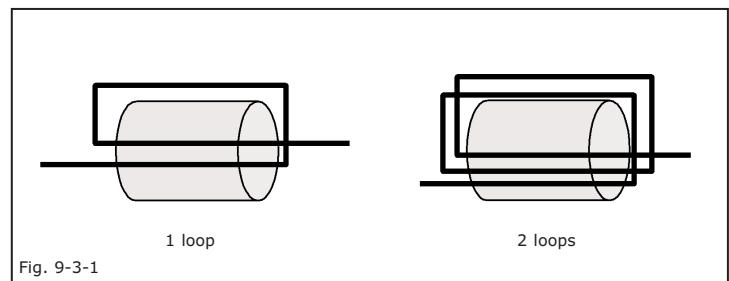

10 EUROPEAN CONTACT LIST

SMC Corporation

Country	Telephone	Country	Telephone
Austria	(43) 2262-62 280	Italy	(39) 02-92711
Belgium	(32) 3-355 1464	Netherlands	(31) 20-531 8888
Czech Republic	(420) 5-414 24611	Norway	(47) 67 12 90 20
Denmark	(45) 70 25 29 00	Poland	(48) 22-548 50 85
Finland	(358) 9-859 580	Portugal	(351) 22 610 89 22
France	(33) 1-64 76 1000	Spain	(34) 945-18 4100
Germany	(49) 6103 4020	Sweden	(46) 8-603 0700
Greece	(30) 1- 342 6076	Switzerland	(41) 52-396 3131
Hungary	(36) 1-371 1343	Turkey	(90) 212 221 1512
Ireland	(351) 1-403 9000	United Kingdom	(44) 1908-56 3888

Websites

SMC Corporation	www.smcworld.com
SMC Europe	www.smceu.com