



# Installation and Maintenance Manual

## Bar Type Ionizer

### Series IZS31



CE (EMC directive: 89/336/EEC, 92/31/EEC, 93/68/EEC)  
 Low Voltage Directive: 73/23/EEC, 93/68/EEC  
 Protection Class: Class III equipment (according to EN60950-1)

## 1 Safety Instructions

- This manual contains essential information for the protection of users and others from possible injury and/or equipment damage.
- Read this manual before using the product, to ensure correct handling, and read the manuals of related apparatus before use.
- Keep this manual in a safe place for future reference.
- These instructions indicate the level of potential hazard by label of "DANGER", "WARNING" or "CAUTION", followed by important safety information which must be carefully followed.
- To ensure safety ISO4414: Pneumatic fluid power and JIS B 8370: Pneumatic system axiom must be observed, along with other relevant safety practices.

<b>⚠ DANGER</b>	In extreme conditions, there is a possibility of serious injury or loss of life.
<b>⚠ WARNING</b>	If instructions are not followed there is a possibility of serious injury or loss of life.
<b>⚠ CAUTION</b>	If instructions are not followed there is a possibility of injury or equipment damage.

### 1.1 General Recommendations

#### ⚠ WARNING

#### 1. The compatibility of equipment is the responsibility of the person who designs the systems or decides the specifications.

Since the products specified here can be used in various operating conditions, their compatibility with the specific system must be based on specifications or after analysis and/or tests to meet your specific requirements. Those who decide the compatibility of equipment shall take the responsibility to guarantee the initial system performance and safety. Construct the system after reviewing all the specifications in the latest catalogue or documentation, as well as, considering the possibility of equipment in every application.

#### 2. Only trained personnel should operate machinery and equipment.

This product generates high voltages, therefore it can be dangerous if an operator is unfamiliar with it. Assembly, handling or repair of systems should be performed by trained and experienced personnel.

#### 3. Do not service machinery/equipment or attempt to remove components until safety is confirmed.

- Inspection and maintenance of the machinery and equipment should be performed after confirmation of safety, considering such areas as earthing, prevention of electric shock and other types of injury.
- When equipment is to be removed, confirm the safety process as mentioned above. Cut air pressure and electrical power supplies which are the energy sources for the equipment and exhaust all residual compressed air in the system.
- Before machinery/equipment is re-started, take measures to prevent short circuit, etc.

#### 4. Do not use product under the following conditions or environments. If it is not avoidable, take appropriate measure and contact SMC.

- Conditions and environments beyond the given specifications or if product is to be used outdoors.
- Installation on equipment in conjunction with atomic energy, railway, air navigation, vehicles, medical equipment, food and beverage, recreation equipment, emergency stop circuits, press applications or safety equipment.

## 1 Safety Instructions (continued)

- An application, which has the possibility of having negative effects on people, property, or animals require a special safety analysis.

### 1.2 Specific Recommendations

#### ⚠ WARNING

#### 1. This product is intended for use in general factory automation systems.

If other applications (especially the ones indicated in section 4 above) are used, please contact SMC before use.

#### 2. Use within specified voltage and temperature limits.

Voltage out of specification may cause malfunction, damage, electric shock and/or fire.

#### 3. Use clean, compressed air for fluid.

Do not use flammable or explosive gas for fluid as it may cause fire or explosion. When fluids other than compressed air are used, please contact SMC service representative.

#### 4. This product does not have an explosion-proof construction.

Do not use this product in areas where dust explosion might be triggered or where flammable or explosive gas is present. It may cause explosion and/or fire.

#### ⚠ CAUTION

#### 1. This product has not been flushed.

When using this product in a clean room environment, flush and confirm the product's purification level before use.

## 2 Intended Conditions of Use

### 2.1 Specifications

Ionizer model	IZS31 (NPN)	IZS31P (PNP)	
Type	Corona discharge		
Voltage supply method	Sensing DC, pulse DC, Plus DC, Minus DC		
Discharge output	+/- 7000 V		
Ion balance *1	+/-30 V		
	(For stainless steel electrodes, ±100 V)		
Purge air	Fluid	Air (Clean, dry air)	
	Op. pressure (max.)	0.7 MPa	
	Connection tube size (mm)	φ4	
Power supply voltage	24 VDC +/- 10 %		
Current consumption (max. value)	Sensing DC mode	200 mA (When sensor is standby: 120 mA)	
	Pulse DC mode	200 mA (When sensor is not used: 170 mA)	
	DC mode	170 mA or less	
Input signal	Discharge stop signal	No voltage contact signal	
	Maintenance start-up signal		
Output signal	Completion signal for static charge elimination	Maximum load current : 100 mA	Maximum Load current: 100 mA
	Maintenance output signal	Residual voltage : 1V or less	Residual voltage: 1 V or less
	Signal for failure	(when the load current is 100 mA)	(With load current of 100 mA)
	Sensor monitor output *2	Max. applied voltage: 28 VDC	
Effective elimination distance	50 to 2000 mm (with sensing DC mode: 200 to 2000 mm)		
Ambient temperature	0 to 50 °C		
Ambient humidity	35 to 80 % RH (Non condensing)		
Material	Ionizer cover: ABS Electrodes: Tungsten, single crystal silicon, stainless steel		
Vibration resistance	Endurance 50 Hz Amplitude 1mm		
Impact resistance	2 hours to X, Y, Z each direction of vibration		
Applicable standard/ directive	10G CE (EMC directive: 89/336/EEC, 92/31/EEC, 93/68/EEC) Low Voltage Directive: 73/23/EEC, 93/68/EEC		

\*1: The distance between the charged object and ionizer is 300 mm or more. (With air purge.)

\*2: When the potential of the charged object is measured with the feedback sensor, the relation between the charged potential and the sensor monitor output voltage and the sensor detecting range will vary depending on the installation distance between the ionizer and the sensor.

## 2 Intended Conditions of Use (continued)

### 2.2 Outline

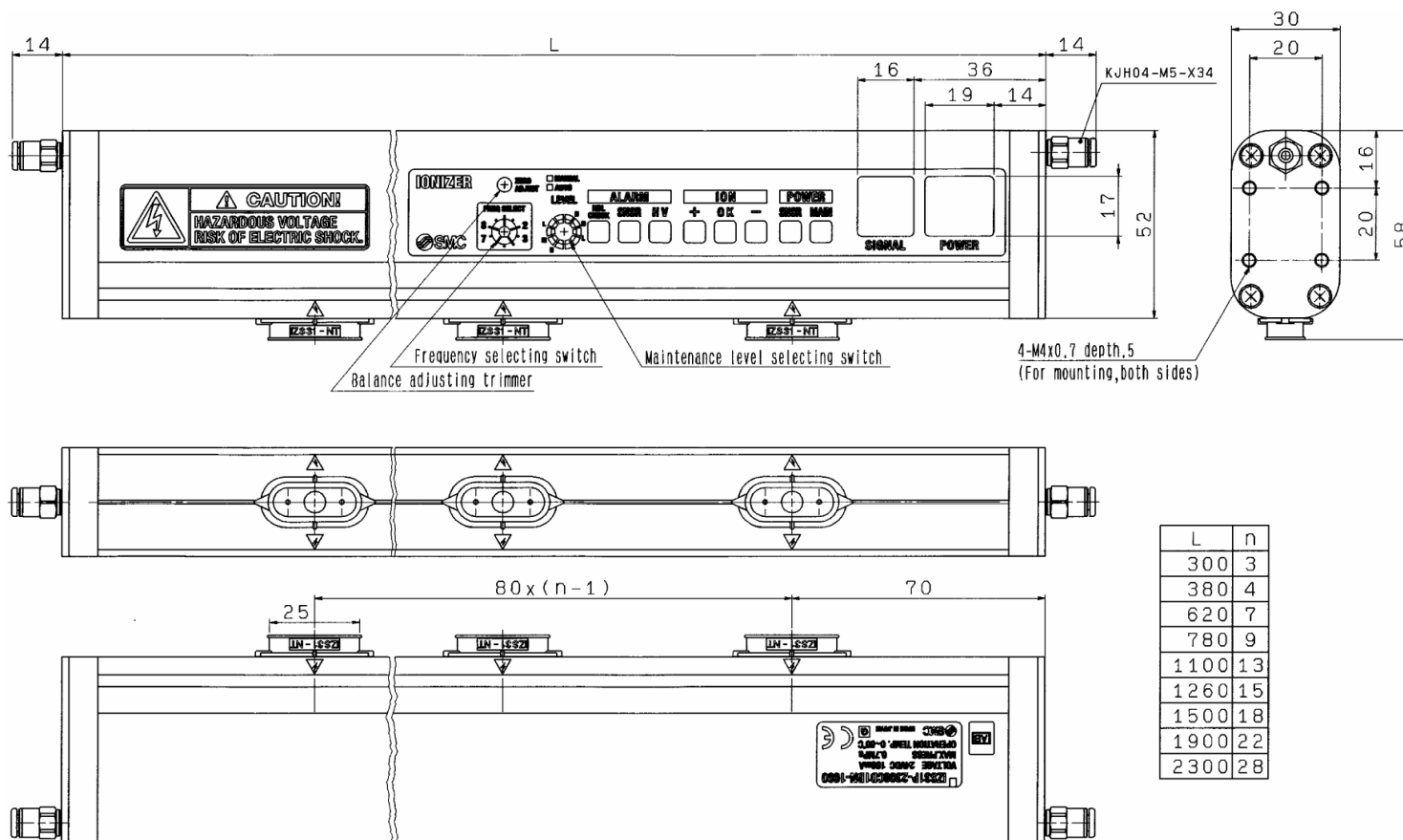

## 3 Installation

### 3.1 Environment

#### ⚠ WARNING

#### 1. Use within operating fluid and ambient temperature range.

The operating fluid and ambient temperature range for Ionizer, feedback sensor and auto-balance sensor is 0 to 50°C. In areas where sudden temperature changes occur, even when these changes are within the specified temperature range, condensation may form. The Ionizer should not be used in such conditions.

#### 2. Do not use this product in an enclosed space.

This product utilizes the corona discharge phenomenon. Since this process generates a small amount of ozone and NOx, only use the Ionizer in open, well-ventilated areas.

#### 3. Environments to avoid

Do not use or store under the following conditions, as these may cause equipment failure:

- Ambient temperatures outside the range 0 to 50°C.
- Ambient humidity outside the range 35 to 85% RH.
- Areas where rapid temperature changes may cause condensation.
- Areas where corrosive gas, flammable gas or other volatile flammable substances are stored.
- Areas where the product may be exposed to conductive powder, such as, iron powder or dust, oil mist, salt, organic solvent, machining chips, particles or cutting oil.
- Directly in the path of air conditioners.
- In enclosed, poorly ventilated areas.
- Exposed to the direct sunlight and/or radiant heat.
- Areas where strong electromagnetic noise is generated (strong electric or magnetic fields, large surges).
- Areas prone to electro-static discharge.
- Areas where RF noise is generated.
- Areas prone to lightning strikes.
- Areas where the product is directly exposed to vibration and/or impact.

### 3 Installation (continued)

- Subject to weight or mechanical stresses that could cause deformation of the product.

If any of these conditions are unavoidable, take appropriate protection measures.

#### 4. Do not use air containing mist or dust.

Air containing mist or dust may lower function and shorten the maintenance cycle. Use a dryer (IDF series), air filter (AF/AFF series), and mist separator (AFM/AM series) to produce clean, compressed air.

#### 5. Ionizer, feedback sensor and auto-balance sensor are not proof against lightning strikes.

Protection against electrical surges due to lightning should be incorporated into the equipment.

### 3.2 Wiring and Piping

#### ⚠ WARNING

- Only connect to SELV type external circuits.
- Ensure that the power supply capacity is sufficient and the voltage is within specification, before connecting.
- Always use a UL listed / recognized power supply which has to be a class 2 power supply with 24Vdc and under 2.1A.
- To maintain product performance, and to prevent electrical shock, connect a protective earth in accordance with instructions in this manual. Ensure that the resistance between the lead wire and ground is less than 100Ω.
- Be sure to cut off power supply when wiring, including connector plug-in/out, as Ionizer may be damaged and cause malfunction.
- Use a dedicated cable to connect the Ionizer with the feedback or auto-balance sensor, and do not disassemble and/or modify the cable.
- Check wiring is correct and confirm safety, before powering up the product. Incorrect wiring may cause product damage or malfunction.
- Do not route wires and cables together with power or high-voltage cables to prevent malfunction due to noise.
- Flush pneumatic piping before installation. Ensure that all dust, water droplets, oil, etc. are removed before piping.

### 3 Installation (continued)

#### 3.3 Electrical connection

##### NPN Circuit

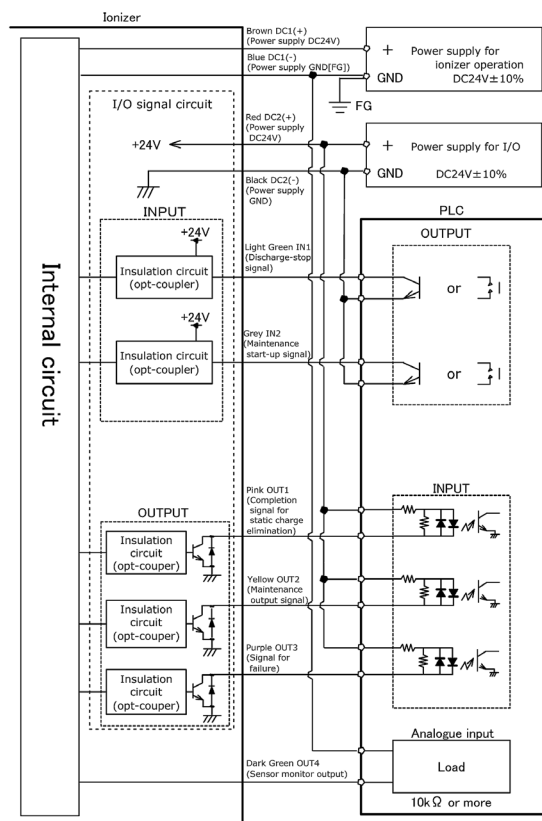

Note: The sensor monitor output (OUT4:Dark Green) is not isolated from the internal circuit of the ionizer; therefore, the return path is to ground (FG).

##### PNP Circuit

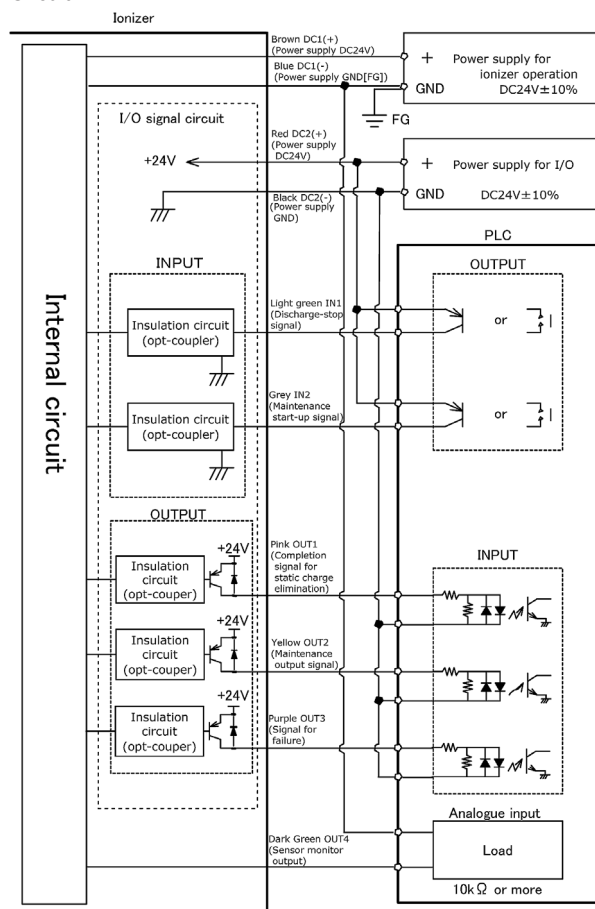

Note: The sensor monitor output (OUT4:Dark Green) is not isolated from the internal circuit of the ionizer; therefore, the return path is to ground (FG).

### 3 Installation (continued)

#### Wiring Tables

Connect dedicated power supply cables.

Connection details for ionizer operation

Symbol	Cable colour	Cable name	Connection	Description
DC1(+)	Brown	Power supply 24 VDC	○	Power supply for ionizer operation
DC1(-)	Blue	Power supply GND [FG]	○	
OUT4	Dark Green	Sensor monitor output	Δ	Analogue O/P (1 to 5V) proportional to static charge present on work-piece

Be sure to ground DC1(-) [Blue]. To prevent possible damage to the ionizer, ensure that the resistance between the lead wire and ground is less than 100Ω.

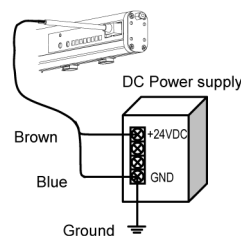

Connection details for I/O signals

Symbol	Cable colour	Cable name	Connection	Description
DC2(+)	Red	Power supply 24 VDC	○	Power supply for I/O signal
DC2(-)	Black	Power supply GND	○	
IN1	Light Green	Discharge-stop signal	○	Signal for starting/ stopping ion generation (NPN type) Operation will begin when IN1 is connected with DC2(-)[Black]. (PNP type) Operation will begin when IN1 is connected with DC2(+)[Red].
IN2	Grey	Maintenance start-up signal	Δ	Input to begin a contamination level check of electrodes, and determine if cleaning is necessary.
-	White	-	-	-
-	Orange	-	-	-
OUT1	Pink	Completion signal for static charge elimination	Δ	Output is ON when the contamination of electrodes is being checked and when the static charge of the work-piece is outside of specification (+/- 30V).
OUT2	Yellow	Maintenance output signal	Δ	Output is ON when cleaning of electrodes is required.
OUT3	Purple	Failure signal	Δ	Output is ON if abnormally high voltage, and/or sensor, and/or CPU failure. (B contact output)

○ : Minimum number of wires required to operate the ionizer.  
 Δ : Wires required to operate the functions.  
 - : Wires not required for the sensing DC mode. These wires should not be short-circuited with other wires.

### 3 Installation (continued)

#### 3.4 Mounting

#### WARNING

1. Install only where there is adequate space for maintenance, wiring and piping.

When installing the electrical connector and one touch pneumatic fitting, ensure sufficient room is left for easy insertion and removal of electrical cable and pneumatic tube.

Do not install with sharp bends in the cable or tube. With consideration of the minimum bend radii given below, ensure that cable and tube entries are straight, and do not apply stress to the electrical connectors or pneumatic fittings. If the connectors or fittings are subject to mechanical stress, malfunctions such as broken wires, air leaks or fire may occur.

Minimum bending radius: Power supply cable .....35 mm  
 Sensor cable .....25 mm

Note: These are minimum bend radii at 20°C. If installation is at a lower temperature, the values will be greater.

Refer to specific catalogue for the minimum bend radius of the pneumatic tube.

2. Install only on a flat surface.

A curved or uneven mounting surface may cause excessive force to be applied to the frame or case. This force, as well as a heavy impact (e.g. from dropping the ionizer) may result in damage and failure.

3. Do not use in areas subject to electrical noise.

It may cause malfunction, deterioration or damage to internal components. Take measures to prevent noise at source and avoid power and signal lines from coming into close contact.

4. Tighten with the specified torque.

Refer to the following table for the correct tightening torque. If the tightening torque is exceeded the mounting screws and brackets may be broken. If the tightening torque is not reached, the mounting screws and brackets may become loose.

Screw size	Recommended tightening torque (N·m)
M3	0.61 to 0.63
M4	0.73 to 0.75
M5	1.3 to 1.5

5. Do not touch the electrodes with a finger or metal tool directly. It may cause injury or malfunction.

If the electrodes are touched with a finger, injury or damage may result or if the electrodes are touched with metal tools damage may result. This may interfere with the specified function and performance, but may also cause operational failure or accident.

Caution for High Voltage

Do not touch the electrodes. High voltage is present. If foreign substances are inserted or persons come into contact with the electrodes, they may be injured by an electric shock or by trying to avoid one.

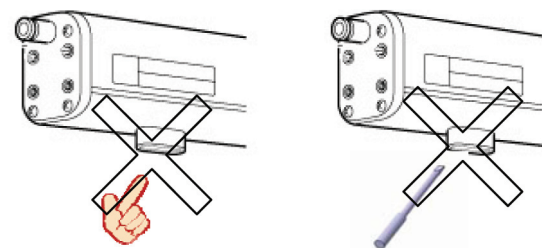

6. Do not attach tape or seal to the product body.

If conductive adhesive or reflective paint is contained in the tape or seal, dielectric phenomenon will occur due to the ions emitted by the ionizer and it may lead to electrostatic charge or electric leakage.

7. Be sure to install or adjust only after power supply is stopped.

### 3 Installation (continued)

#### CAUTION

1. Keep the minimum free space (as shown in the diagrams), around the ionizer for correct operation, installation and maintenance.

Walls or other objects that are present within the minimum free space area can interfere with the operation of the ionizer, reducing the efficiency of static charge removal.

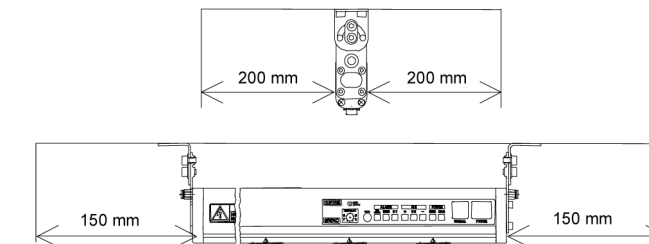

2. Be sure to check the effect of static charge removal after installation.

The effectiveness of static charge removal varies depending on the installation and operating conditions.

#### 3.4.1 Installation of Ionizer Body

Investigate the places where static problems occur, or places where processes and parts generate ESD (electro-static discharge), and carefully consider the required conditions to ensure appropriate static charge removal before installation.

##### 1. Installation height

When the ionizer is installed, keep the distance between charged objects and the ionizer within the range below.

Ion-production frequency [Hz]	Distance between the charged objects and Ionizer (mm)	
	With air purge (note)	Without air purge
1	400 to 2000	400 to 500
3	300 to 2000	300 to 400
5	300 to 2000	300 to 400
10	200 to 2000	200 to 300
15	200 to 2000	200 to 300
20	150 to 2000	150 to 250
30	50 to 2000	50 to 200
60	50 to 2000	50 to 150

Note: The installation heights stated above are nominal values; check the efficiency of operation before installation.

The minimum installation height should be greater than 200 mm when the feedback sensor is used.

When the auto-balance sensor is used, the installation height should be greater than 100 mm.

When the ionizer is used outside of these conditions, ensure the correct operation of the sensors.

### 3 Installation (continued)

2. Mount end brackets on both sides of the Ionizer body with the supplied M4 screws.

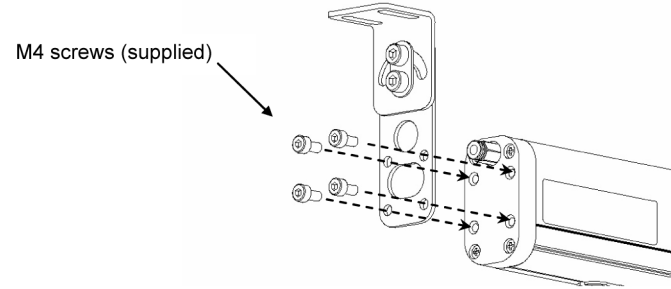

3. Mount intermediate brackets on the Ionizer body at regular intervals.

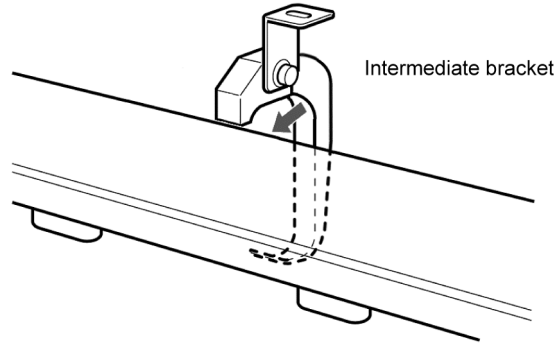

4. Tap M5 threads on the mounting positions of the brackets, and fix the Ionizer body and brackets with M5 screws.

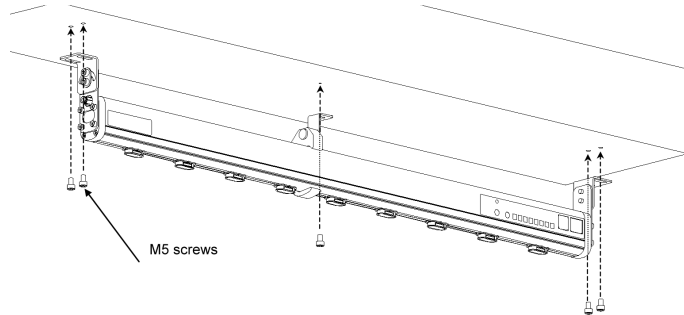

5. Adjust angle of the ionizer body to ensure proper static charge removal, and fix it in position with the bracket locking screws (M5).

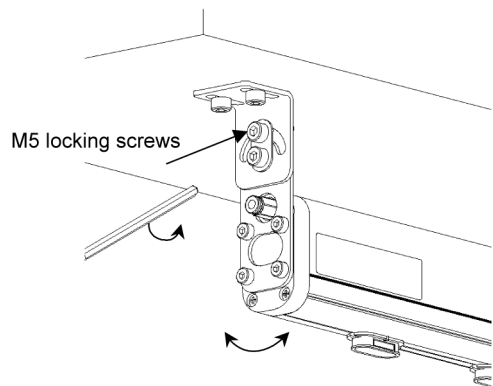

### 3 Installation (continued)

6. Make certain the DC1 (-) lead wire [blue] of the power supply cable is connected to protective ground.

Resistance between the lead wire and ground must be less than 100Ω. If the lead wire is not grounded, the ion balance will be unstable, and there will be the possibility of electric shock, also the Ionizer and connected power supply may be damaged.

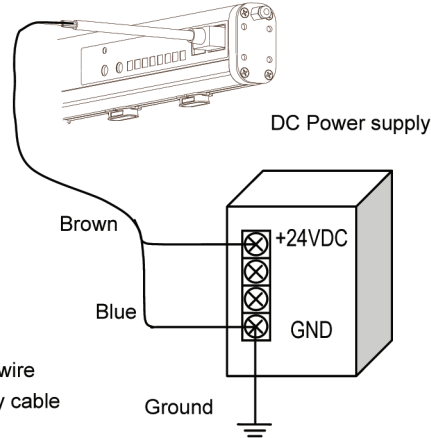

Ground the DC1 (-) lead wire [blue] of the power supply cable

#### 3.4.2 Installation of sensors

##### 1. Installation of sensor head

###### Feedback sensor

Point the detecting hole of the sensor head towards the charged object to accurately measure the object's static charge. Ensure the distance between the detecting hole and surface of the charged object is between 10 and 50 mm. Do not allow the feedback sensor to come into contact with the charged object. The detecting area and sensor output will vary depending on the distance between the surface of the charged object and sensor.

Mount the sensor head with two off M3 screws (sold separately).

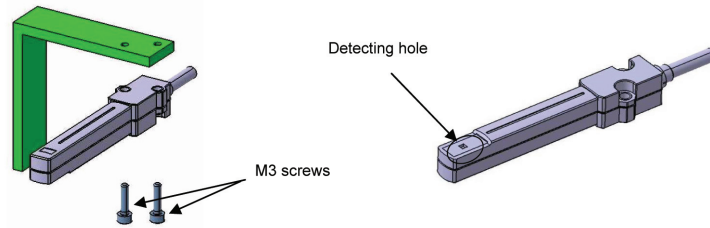

The sensor head case is connected to GND, therefore when installing the power supply, it is very important to take great care that there is not a short circuit between GND and 24V.

Do not insert foreign objects into the detecting hole. The detecting hole is open to enable the measurement of static electricity. If foreign objects, such as tools are inserted into it, the sensor will be damaged. The Ionizer will not function correctly with a damaged sensor.

Do not pull the cable out of the sensor head. If the cable is pulled with excessive force, the sensor head may be damaged.

###### Auto-balance sensor

Position the auto-balance sensor directly under the Ionizer, with its metal plate facing upwards. The ion balance will change depending on the installation height, so the sensor should be installed on a level as close as possible to that of the work-piece. The auto-balance sensor can be removed once the ion balance adjustment is completed.

Keep the height between the auto-balance sensor and Ionizer within the installation height stated in 2.1.

Mount the sensor head with 2 off M3 screws (sold separately).

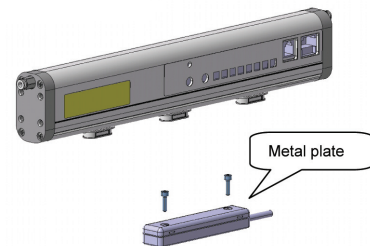

### 3 Installation (continued)

#### 2. Installation of the sensor amplifier

The sensor amplifier should be fixed with 2 off M3 screws (sold separately).

Do not pull the cable out of the sensor amplifier. If the cable is pulled with excessive force, the amplifier may be damaged.

Ensure the case of the sensor amplifier is grounded (resistance between the lead wire and ground must be less than 100Ω). The amplifier case surface is treated with conductive plating, therefore, when the mounting surface itself is grounded, it is not necessary to provide a separate connection to ground. If, however, the mounting surface is insulated (by paint or anodising for example), the case must be wired to ground.

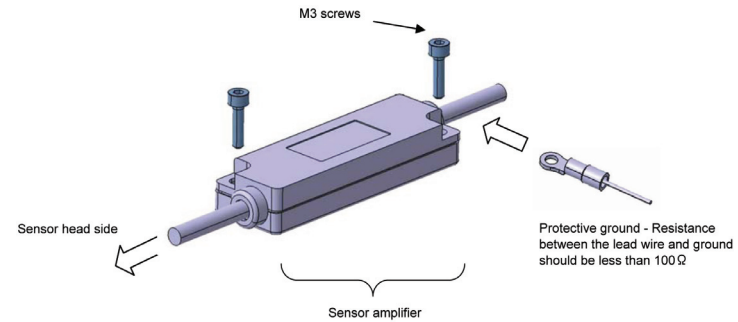

### 4 Settings (continued)

Mode	Operation details		Switch setting
Energy-saving mode	When the static charge elimination is complete, ion generation will cease.		8
Continuous elimination mode	When static charge elimination is complete, the ionizer will continue to operate in pulse DC mode. The ion balance will be maintained within +/-30V and ion generation will be at the selected frequency.		0 ••• 1 Hz 1 ••• 3 Hz 2 ••• 5 Hz 3 ••• 10 Hz 4 ••• 15 Hz 5 ••• 20 Hz 6 ••• 30 Hz 7 ••• 60 Hz

#### 4.2 Pulse DC mode

##### 1. LEVEL selector dial (maintenance level and auto-ion balance)

When ion balance is adjusted using the auto balance sensor, either manual or auto mode can be selected.

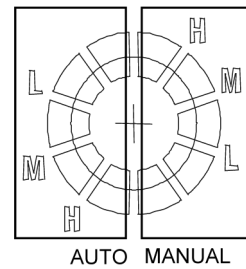

### 4 Settings

#### 4.1 Sensing DC mode

##### 1. LEVEL selector dial (maintenance level)

Use the maintenance level selector dial to choose from three different contamination detection levels:

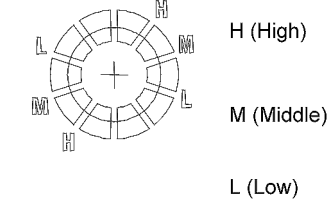

**H (High)**  
Notification will be before static charge elimination time is affected (very slight contamination will be detected)

**M (Middle)**  
Notification will be before there is a large change in static charge elimination time.

**L (Low)**  
Notification will be when the static charge elimination time is significantly longer than normal.

The contamination detection function is performed when the maintenance start-up signal is input.

##### 2. FREQ SELECT dial (energy saving or continuous elimination)

In sensing DC operation, there are two modes of use: Energy saving and continuous elimination.

In energy saving mode, when static charge removal is complete, the ionizer stops generating ions.

In continuous elimination mode, when static charge elimination is complete, the ionizer continues to operate in pulse DC mode. The frequency of operation of pulse DC mode must be selected.

The FREQ SELECT dial is used to select which mode (and frequency), the ionizer will operate in.

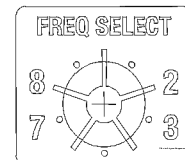

Mode	Description	Switch setting
Manual	Ion balance is adjusted when the maintenance start-up signal is input or when the power supply of the Ionizer is applied. The ion-balance adjustment values are retained for each ion-generation frequency. When the ion-generation frequency is changed, adjust the ion balance. Once the ion-balance adjustment is completed, the ion balance adjustment will not be repeated until the maintenance start-up signal is input again. Therefore, the auto balance sensor can be removed.	MANUAL
Auto	Ion-balance is continuously adjusted. If the auto-balance sensor is removed, manually adjust the ion-balance with the balance adjustment trimmer.	AUTO

\* Position the dial in line with the desired detection level of electrode contamination.

When the ionizer is used without the auto-balance sensor, change the dial setting to AUTO, and manually adjust the ion-balance with the balance adjustment trimmer.

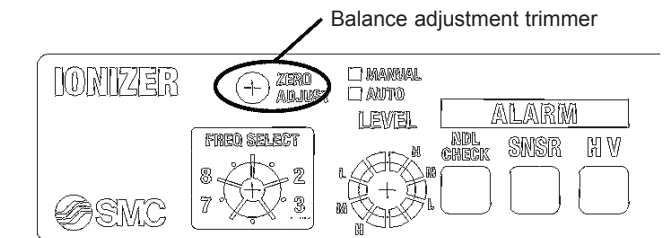

## 4 Settings (continued)

The electrode contamination detection level must be set. Choose from three different levels: L (Low), M (Medium) or H (High).

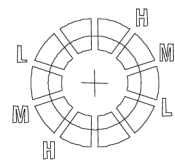

H (High)

Notification will be before static charge elimination time is affected (very slight contamination will be detected)

M (Middle)

Notification will be before there is a large change in static charge elimination time.

L (Low)

Notification will be when the static charge elimination time is significantly longer than normal.

The contamination detection function is performed when the maintenance start-up signal is input.

If H, M and L levels are set, ion balance adjustment will be performed after the contamination detection.

### 2. FREQ SELECT dial (ion generation frequency)

The ionizer can operate over a range of several frequencies, to suit different applications. The desired ion generation frequency should be selected using the FREQ SELECT dial:

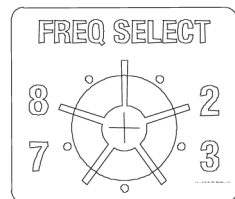

Ion-generation frequency (Hz)	Dial position
1	0
3	1
5	2
10	3
15	4
20	5
30	6
60	7

### 4.3 DC mode

#### 1. FREQ SELECT dial (polarity of emitted ions)

The ionizer can emit a constant stream of either positive or negative ions. Use the FREQ SELECT dial to select the desired polarity:

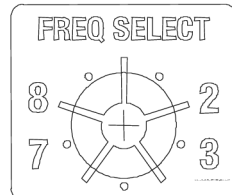

Ion discharge polarity	Dial position
Positive	8
Negative	9

## 5 Maintenance

### ⚠ WARNING

1. Do not drop, hit an object or cause excessive impact (10G or more) when handling. Although externally the Ionizer may not appear to be broken, there may be internal damage causing malfunction.
2. When the cable is inserted or removed, pinch modular plug spring clip with finger and insert or remove the plug in a straight line. If inserted or removed in an inappropriate direction, the mounting part of the modular jack might be damaged leading to operational failure.

### ⚠ CAUTION

#### 1. Keep electrodes clean with regular maintenance.

Make sure that the equipment is operating without any errors by regular maintenance. Only people with sufficient knowledge and experience should perform maintenance of the equipment. Contamination adhering to the electrodes, due to long operating periods, reduces the ability of the Ionizer to eliminate static electricity. If, after cleaning the electrodes, the Ionizer does not regain its correct performance, the electrodes should be replaced. In order to maintain stable performance, regular maintenance and cleaning of electrodes is recommended.



Caution  
for High Voltage

A high voltage generating circuit is installed. Ensure the supply voltage is removed before any maintenance is performed. Do not disassemble or modify the product as it may reduce efficiency of the functions and cause injury due to electric shock or electric leakage.

#### 2. The power supply must be removed when cleaning the electrodes, or changing the electrode cartridge.

To avoid the risk of electric shock, do not touch the electrodes whilst the ionizer has power connected.

#### 3. Do not open the case to disassemble and reconstruct the product.

It may cause electric shock, operational failure and/or disaster, such as, fire. In addition, note the product, which is disassembled or reconstructed, may not satisfy the functions and performance in the specifications and is out of guarantee.

#### 4. Do not operate the product with wet hands.

There is a danger of electric shock.

## 6 Limitations of Use

### ⚠ WARNING

- Do not exceed any of the specifications laid out in section 2 of this document or the specific product catalogue.

## 7 Contacts

AUSTRIA	(43) 2262-62 280	ITALY	(39) 02-92711
BELGIUM	(32) 3-355 1464	NETHERLANDS	(31) 20-531 8888
CZECH REP.	(420) 5-414 24611	NORWAY	(47) 67 12 90 20
DENMARK	(45) 70 25 29 00	POLAND	(48) 22-548 50 85
FINLAND	(358) 207-513 513	PORTUGAL	(351) 2 610 89 22
FRANCE	(33) 1-64 76 1000	SPAIN	(34) 945-18 4100
GERMANY	(49) 6103 4020	SWEDEN	(46) 8-603 0700
GREECE	30) 1- 342 6076	SWITZERLAND	(41) 52-396 3131
HUNGARY	(36) 1-371 1343	TURKEY	(90) 212 221 1512
IRELAND	(353) 1-403 9000	UNITED KINGDOM	(44) 1908-56 3888

SMC Corporation www.smcworld.com (Global) www.smceu.com (Europe)

Specifications are subject to change without prior notice from the manufacturer. The descriptions of products in this document may be used by other companies.

© SMC Corporation All Rights Reserved.