



Installation and Maintenance Manual Series ITV2000, ITV3000, ITV2090 Electro-Pneumatic Regulator

For future reference, please keep this manual in a safe place

This manual should be read in conjunction with the current catalogue

Safety Instructions

These safety instructions are intended to prevent a hazardous situation and / or equipment damage. These instructions indicate the level of potential hazard by label of "Caution", "Warning", or "Danger". To ensure safety, be sure to observe ISO 4414 (Note 1), JIS B 8370 (Note 2) and other safety practices.

(Note 1): ISO 4414: Pneumatic fluid power-Recommendations for the application of equipment to transmission and control systems.
(Note 2): JIS B 8370 : Pneumatic system axiom

CAUTION: Operator error could result in injury or equipment damage.

WARNING: Operator error could result in serious injury or loss of life.

DANGER: In extreme conditions, there is a possible result of serious injury or loss of life.

WARNING

1. **The compatibility of pneumatic equipment is the responsibility of the person who designs the pneumatic system or decides its specifications.**

Since the products specified here are used in various operating conditions, their compatibility for the specific pneumatic system must be based on specifications or after analysis and/or tests to meet your specific requirements .

2. **Only trained personnel should operate pneumatically operated machinery and equipment.**

Compressed air can be dangerous if an operator is unfamiliar with it. Assembly, handling or repair of pneumatic systems should be performed by trained and experienced operators.

3. **Do not service machinery / equipment or attempt to remove component until safety is confirmed.**

- 1) Inspection and maintenance of machinery / equipment should only be performed after confirmation of safe locked-out control positions.
- 2) When equipment is to be removed, confirm the safety process as mentioned above. Switch off air and electrical supplies and exhaust all residual compressed air in the system.
- 3) Before machinery / equipment is re-started, ensure all safety measures to prevent sudden movement of cylinders etc. (Supply air into the system gradually to create back-pressure, i.e. incorporate a soft-start valve.)

4. **Contact SMC if the product is to be used in any of the following conditions:**

- 1) Conditions and environments beyond the given specifications, or if product is used outdoors.
- 2) Installation on equipment in conjunction with atomic energy, railway, air navigation, vehicles, medical equipment, food and beverage, recreation equipment, emergency stop circuits, press applications, or safety equipment.
- 3) An application which has the possibility of having negative effects on people, property, or animals requiring special safety analysis.

CAUTION

Ensure that the air supply system is filtered to 5 micron

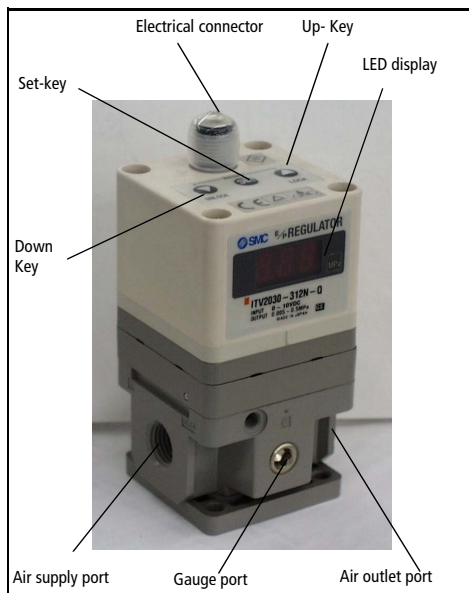

Fig 1

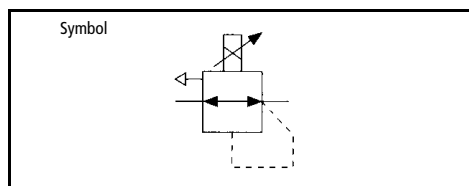

Fig 2

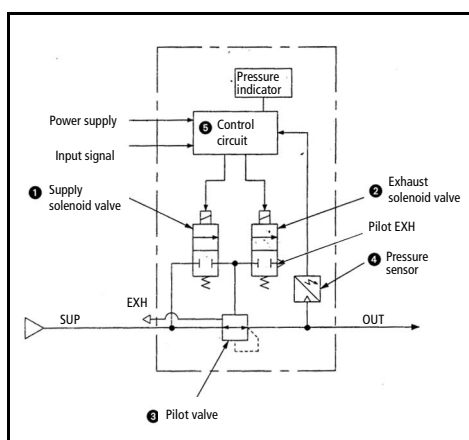

Fig 3

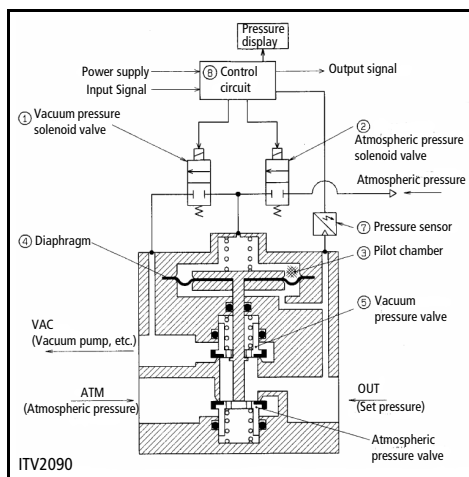

Fig 4

Specifications

Model	ITV201□	ITV203□	ITV205□	ITV209□
	ITV301□	ITV303□	ITV305□	
Min. Supply Pressure	Setting Pressure + 0.1 MPa			
Max. Supply Pressure	0.2 MPa (2.0 kgf/cm ²)	1.0 MPa (10.2 kgf/cm ²)	-101kPa (-760mmHg)	
Setting Pressure Range	0.005~0.1MPa (0.05~1.0kgf/cm ²)	0.005~0.5MPa (0.05~5.1kgf/cm ²)	0.005~0.9MPa (0.05~9.2kgf/cm ²)	-1.3~80kPa (-10~600mmHg)
Max. Flow Rate	1500 l/min (ITV20#0) , 5000 l/min (ITV30#0)			
Supply voltage	24 VDC±10%: 0.12A or less 12-15VDC: 0.18A or less			
Input Signal	Current Type (Note 1)	4-20mADC, 0-20mADC		
	Voltage Type	0-5VDC, 0-10VDC		
Input Impedance	Current Type	250Ω or less		
	Voltage Type	approx. 6.5kΩ		
Output signal (Note 2)	Analog Output	1-5VDC (Load Impedance: 1kΩ or less)		
	Switch Output	NPN Open Collector Type : 30V 30mA PNP Open Collector Type : 30mA		
Linearity	±1% or less (Full Scale)			
Hysteresis	0.5% or less (Full Scale)			
Repeatability	±0.5% or less (Full Scale)			
Sensitivity	0.2% or less (Full Scale)			
Temperature Characteristics	±0.12% or less (Full Scale)/°C			
Protection Structure	Main unit: IP65, Cable connector: IP67			
Display of Pressure	Accuracy	±3% (Full Scale)		
	Min. Unit	MPa: 0.01, kgf/cm ² : 0.01, bar: 0.01, PSI: 0.1 (note 3), kPa: 1	kPa: 1	
Ambient and fluid temperature	0-50 °C (without condensation)			

(Note 1) Two wire control, 4 to 20 mADC and 0 to 20mADC are not available. Supply voltage of 12-15VDC or 24 VDC is required.

(Note 2) Make selection of Analog output or Switch output. Also select NPN or PNP output when Switch output is selected.

(Note 3) 1PSI is the minimum unit on ITV205□ or ITV305□

Operation Principle

ITV2000, ITV3000 : When the input signal increases, the supply solenoid valve ① turns on (Refer Fig 3) and the exhaust solenoid valve ② turns off. Supply pressure is passed to the pilot valve ③ through the supply solenoid valve. The pilot valve will open the main valve allowing partial supply pressure to pass to the out port. The pressure sensor ④ will provide output pressure feedback to the control circuit ⑤. The control circuit will balance the input signal and output pressure to ensure that the output pressure remains proportional to the input signal.

ITV2090 : When the input signal increases, the vacuum solenoid valve ① turns ON (Refer Fig 4), and the atmospheric pressure solenoid valve ② turns OFF. Because of this, the VAC and pilot chamber ③ are connected, the pressure in the pilot chamber ③ becomes negative and acts on the top of the diaphragm. As a result, the vacuum pressure valve ④ which is linked to the diaphragm ④ opens, VAC and OUT are connected, and the set pressure becomes negative. This negative pressure feeds back to the control circuit ⑤ via the pressure sensor ⑦. Then, a correct operation works until a vacuum pressure proportional to the input signal is reached, and a vacuum pressure is obtained which is always proportional to the input signal.

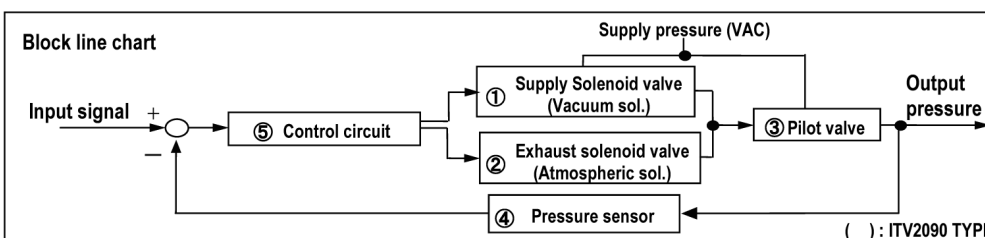
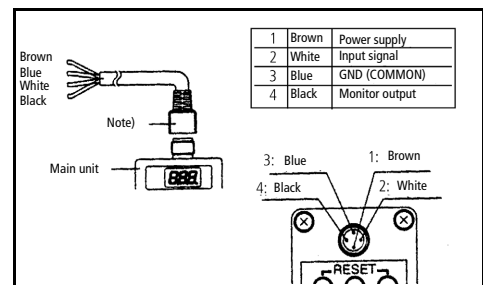

Fig 5

CAUTION

Wiring

Connect the cable to the connector on the main unit as shown in the following diagram. Take precautions as incorrect wiring will damage the unit. Use a DC power supply capable of supplying the necessary power requirements with minimal ripple.



Note: The right angle type connector extends to the left side (over the supply port side)

Wiring diagram

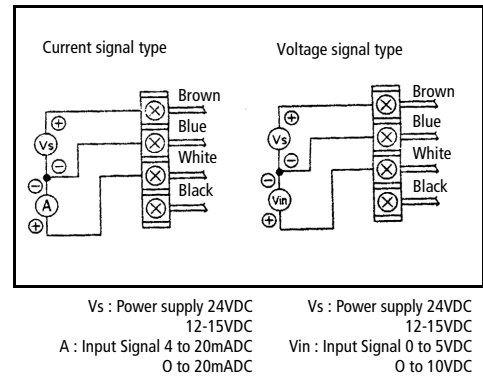

Fig 6

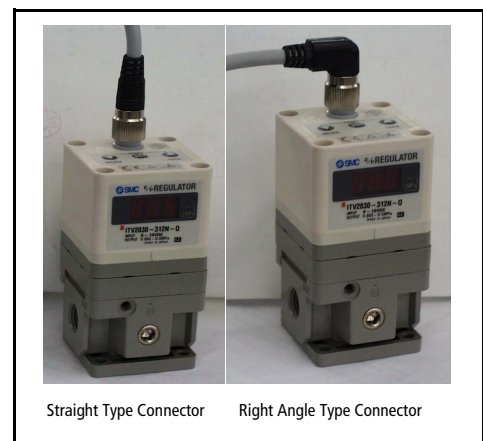

Fig 7

Setting the Regulator

CAUTION

As soon as the 'set' key is operated minimum/maximum pressure will be present at the outlet port.

CAUTION

As soon as primary pressure is applied to the regulator minimum pressure will be present at the outlet port.

- Release 'Key Lock' as explained in section 'Function of Key-Lock'
- To set minimum pressure (display shows F-1) use up/down keys (Fig 1) and press 'Set' key (Fig 1) to 'Lock' setting.
- To set maximum pressure (display shows F-2) use up/down keys (Fig 1) and press 'Set' key (Fig 1) to 'Lock' setting.
- To set switch output 1 (display shows P-1) use up/down keys (Fig 1) and press 'Set' key (Fig 1) to 'Lock' setting.
- To set switch output 2 (display shows P-2) use up/down keys (Fig 1), and press 'Set' key (Fig 1) to 'Lock' setting.

Note 1: If the above sequence has been followed correctly, the settings will complete automatically.

Note 2: If only setting minimum pressure, when pressure is 'Set', pressing the set button once more will 'skip' to the next step.

Function of Key-Lock

With input signal applied



The keys are locked after connecting power, and can not be operated. 'Loc' is indicated on Display (Fig 1) when any keys are pushed.

1. **Key-Lock Release**
 - 1) Push 'Down' key (Fig 1) for longer than 2 seconds.
 - 2) Display will flash 'Loc' (locked).
 - 3) Push 'Set' key (Fig 1) to unlock.
2. **Key-Lock**
 - 1) Push 'Up' key (Fig 1) for longer than 2 seconds.
 - 2) Display will flash 'unL' (unlocked).
 - 3) Push 'Set' key (Fig 1) to lock.

Note: To cancel push 'Down' key (Fig 1).

Function of the 'Error' Display

If an abnormality is detected by the ITV2000 the LED display (Fig 1) will show 'Er' followed by a code number. Isolate the power supply and ascertain and solve the problem. Re-instate power supply after correcting fault.

Error codes are as follows:

N°	Content	Display
1	Input Signal Outside Spec.	Er 1
2	EEPROM Reading/Writing Error	Er 2
3	Memory Reading/Writing Error	Er 3
4	Solenoid Valve Fault	Er 4
5	Switch Output Over-Current	Er 5

Reset Function

Push 'Up' and 'Down' keys (Fig 1) together for longer than 3 seconds. Display shows 'RES'. Release keys to reset minimum pressure, maximum pressure and switch outputs P1 & P2 to start condition.

CAUTION

1. If the electrical supply fails, settings are 'held' for a short period.
2. If the air pressure fails with power 'on' the solenoid will 'flutter'. Turn off the power.
3. If the monitor output function is not used, ensure that the wire is totally insulated.

PNP Circuit

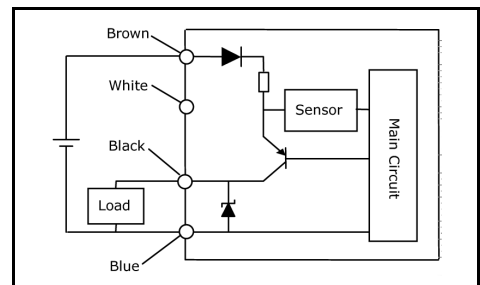

Note: If the supply exceeds 30mA the sensor will output to the LED display and show 'Er 5'.

CAUTION

1. This product is pre-set at the factory and must not be dismantled by the user. Contact your local SMC office for advice.
2. Ensure, when installing this product, that it is kept clear of power lines to avoid noise interference.
3. Ensure that load surge protection is fitted when inductive loads are present (i.e. solenoid, relay etc.).
4. Ensure precautions are in place if the product is used in a 'free flow output' condition. All will continue to flow continuously.
5. Do not use a lubricator on the input side of this product. If lubrication is necessary, place the lubricator on the 'output' side.
6. Ensure all air is exhausted from the product before maintenance.
7. Length of connector cable shall be 10m maximum.

When you enquire about the product, please contact the following SMC Corporation:

	Phone	Phone
AUSTRIA	(43) 2262-62 280	ITALY (39) 02-92711
BELGIUM	(32) 3-355 1464	NETHERLANDS (31) 20-531 8888
CZECH REP.	(420) 5-414 24611	NORWAY (47) 67 12 90 20
DENMARK	(45) 70 25 29 20	POLAND (48) 22-548 50 85
FINLAND	(358) 9-859 580	PORTUGAL (351) 22-610 89 22
FRANCE	(33) 1-64 76 1000	SPAIN (34) 945-18 4100
GERMANY	(49) 6103 4020	SWEDEN (46) 8-603 0700
GREECE	(30) 1-342 6076	SWITZERLAND (41) 52- 396 3131
HUNGARY	(36) 1-371 1343	TURKEY (90) 212 221 1512
IRELAND	(353) 1-403 9000	UK (44) 1908-56 3888