



Installation and Maintenance Manual
IP8100-0#1-#J-X83
Electropneumatic Positioner

1 SAFETY RECOMMENDATION

1.1 General recommendation

These safety instructions are intended to prevent a hazardous situation and/or equipment damage. These instructions indicate the level of potential hazard by label of "Caution", "Warning" or "Danger". To ensure safety, be sure to observe ISO4414 (Note1), JIS B 8370 (Note2) and other safety practices.

Note 1: ISO 4414: Pneumatic fluid power - Recommendations for the application of equipment to transmission and control systems. Note 2: JIS B 8370: Pneumatic system axiom.

CAUTION: Operator error could result in injury or equipment damage.

WARNING: Operator error could result in injury or loss of life.

DANGER: In extreme conditions, there is possible result of serious injury or loss of life.

WARNING

- The compatibility of pneumatic equipment is the responsibility of the person who designs the pneumatic system or decides its specifications. Since the products specified here are used in various operating conditions, their compatibility for the specific pneumatic system must be based on specifications or after analysis and/or tests to meet your specific requirements.
- Only trained personnel should operate pneumatically operated machinery and equipment. Compressed air can be dangerous if an operator is unfamiliar with it. Assembly, handling or repair of pneumatic systems should be performed by trained and experienced operators.
- Do not service machinery/equipment or attempt to remove component until safety is confirmed.
 - Inspection and maintenance of machinery/equipment should only be performed after confirmation of safe locked-out control positions.
 - When equipment is to be removed, confirm the safety process as mentioned above. Switch off air and electrical supplies and exhaust all residual compressed air in the system.
 - Before machinery/equipment is re-started, ensure all safety measures to prevent sudden movement of cylinders etc. (Supply air into the system gradually to create backpressure, i.e. incorporate a soft-start valve).
- Contact SMC if the product is to be used in any of the following conditions:
 - Conditions and environments beyond the given specifications, or if product is used outdoors.
 - Installations in conjunction with atomic energy, railway, air navigation, vehicles, medical equipment, food and beverage, recreation equipment, emergency stop circuits, press applications, or safety equipment.
 - Applications, which have the possibility of having negative effects on people, properties or animals, requiring special safety analysis.

1.2 Conformity to standard

This product is certified to and complies with the following standards:

- EMC Directive 89/336/EEC
- EN61000-6-2:2001 Generic Standards - Immunity for Industrial environments
- EN61000-6-3:2001 Generic Standards - Emission standards for residential, commercial and light industrial environments
- EN55011:1998 Limits and methods of measurement of radio disturbance characteristics of industrial, scientific and medical radio-frequency equipment and light-industrial environments

2 SPECIFICATIONS

Protect the unit from impact and dropping during transfer and when mounted. It may cause failure of the unit.

- Do not use the unit in places with high humidity & temperature. It may cause malfunctions.
- Do not use this positioner outside of the range of it's specifications as this can cause failure.

Item	IP8100	
	Single action	Double action
Input current	4~20mADC (Standard)*1	
Input resistance	235 ± 15Ω (4~20mADC)	
Supply air pressure	0.14~0.7MPa	
Standard stroke	60° ~ 100°*2	
Sensitivity	Within 0.5%F.S.	
Linearity	Within ±2%F.S.	
Hysteresis	Within 1%F.S.	
Repeatability	Within ±0.5%F.S.	
Thermal coefficient	Within 0.1%F.S./°C	
Output flow rate	80 l/min (ANR) or more (SUP=0.14MPa)*3	
Air consumption	Within 5 l/min (ANR) (SUP=0.14MPa)	
Ambient and using fluid temperature	-20°C ~ 80°C	
Air connection port	NPT 1/4 (FEMALE)	
Electric wiring connection port	G1/2 (FEMALE)	
Output Signal	4-20mADC	
Power supply	12 - 35V (for output current detection)	
Resistance Load	< Power Supply-12V 20mADC	
Output characteristic	±2% F.S.	
Hysteresis	1% F.S.	
Temperature Coefficient	0.06% F.S./°C	
Material	Aluminium diecast for the body	
Mass	Approx. 2.6kg	
Classification of degree of protection	JISF8007 IP65 (conform to IEC pub.529)	

*1 : 1/2 split range is possible with the standard type (by adjusting the span)

*2 : The stroke is adjustable in 0-60 and 0-100 .

*3 : Standard air (JIS B0120): temp.20 C, absolute press. 760mmHg, ratio humidity 65%.

2.1 How to Order

IP8100 - 0 1 - J - X83 - Q

EMC CERTIFIED

AIR CONNECTIONS NPT 1/4 (FEMALE)

ACCESSORIES

NIL	NO ACCESSORIES (STANDARD)
A	WITH PILOT VALVE ADDED DIA. 0.7mm ORIFICE FOR RESTRICTING OUTPUT.
B	WITH PILOT VALVE ADDED DIA. 1.0mm ORIFICE FOR RESTRICTING OUTPUT.
C	FORK LEVER ASSEMBLY, TYPE M (P368010-36)
D	FORK LEVER ASSEMBLY, TYPE S (P368010-37)
G	WITH GAIN SUPPRESSION SPRING (A). (WITHOUT STANDARD GAIN SUPPRESSION SPRING)
H	WITH EXTERNAL SCALE PLATE UNIT

NOTE: WHEN MORE THAN 2 ACCESSORIES ARE REQUIRED THE SYMBOL SHOULD BE STATED IN ALPHABETICAL ORDER

PRESSURE GAUGE (SUP, OUT1)

0	None
1	0.2 MPa (R1/8)
2	0.3 MPa (R1/8)
3	1.0 MPa (R1/8)

ACTION

J	WITH OUTPUT CURRENT 4-20mA DC, NORMAL ACTUATION (NON EXPLOSION PROOF)
JR	WITH OUTPUT CURRENT 4-20mA DC, REVERSE ACTUATION (NON EXPLOSION PROOF)

3 INSTALLATION

WARNING

- Do not install unless the safety instructions have been read and understood.
- Since zero-point varies depending on the mounting position, the zero point should be adjusted after installation.
- Avoid hitting the product with metallic objects!
- Avoid using this product in non-explosive environments which can become explosive due to air leakage!

3.1 Environment

WARNING

- Do not use in an environment where the product is directly exposed to corrosive gases, chemicals, salt water, water or steam.
- Do not mount the product in a location where it will be subject to strong vibrations and/or shock.
- Do not mount the product in a location where it is exposed to radiant heat.
- Allow sufficient space for maintenance and adjustment around the product when mounted.

3.2 Piping

CAUTION

- Before piping make sure to clean away all chips, cutting oil, dust etc.
- When installing piping or fitting into a port, ensure that sealant material does not enter the port inside. When using seal tape, leave 1.5 to 2 threads exposed on the end of the pipe/fitting.

3.3 Lubrication

CAUTION

- The positioner has a fixed orifice and nozzle, which contain fine paths in them. Use filtered, dehydrated air and avoid the use of lubricators as this may cause malfunction of the positioner. Ensure that the air supply system is filtered to 5 micron.

3.4 Handling

CAUTION

- Avoid giving impact to the body and torque motor of the positioner, and giving excessive force to the armature because this leads to failure. Handle with care during transport and operation.
- If you leave the positioner at the operation site for a long time without using it, put the cover on it so that rain water does not enter the positioner. If the atmosphere is of high temperature or humidity, take measures to avoid condensation inside. The condensation control measures must be taken thoroughly for export shipment.
- Avoid setting the positioner near magnetic fields because the characteristics are effected.

4 MOUNTING

4.1 Type IP8100

4.1.1 Example of attaching to actuator

The type IP8100 positioner is compatible with type IP610 and IP6100 in the attaching pitch. If you are using IP610 or IP6100 already, the bracket can be used to attach IP8100 to the actuator. If you change from IP6100 to IP8100 and select accessory H (with external scale plate), fork lever type fitting needs to be adjusted at lower position.

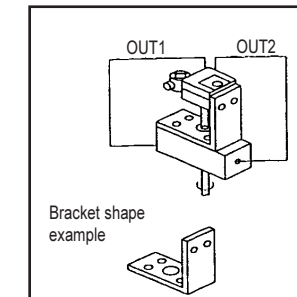

Fig.1 Example of attaching using the positioner side screw

Attaching using the screw hole of a side of the positioner and the screw hole at the actuator top.

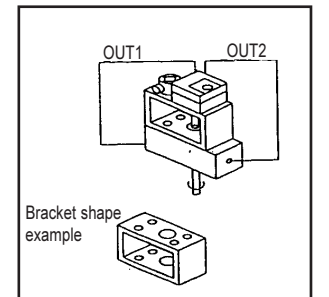

Fig.2 Example of attaching using the positioner back screw

Attaching using the screw hole at the positioner back and the screw hole at the actuator top.

4.1.2 Connection with feedback shaft

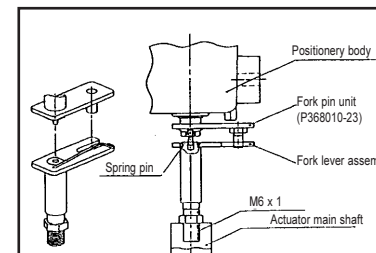

Fig.3 Attaching the feed back lever

- Attach to the position at which the positioner feed back shaft and the rotary actuator main shaft are almost concentric (range in which the spring pin of feed back shaft edge enters the hole of fork lever assembly shaft edge).
- If the seration joint type for IP8100 is made in a special specification, it can be used for this connection.

4.1.3 Cam attaching procedure

CAUTION

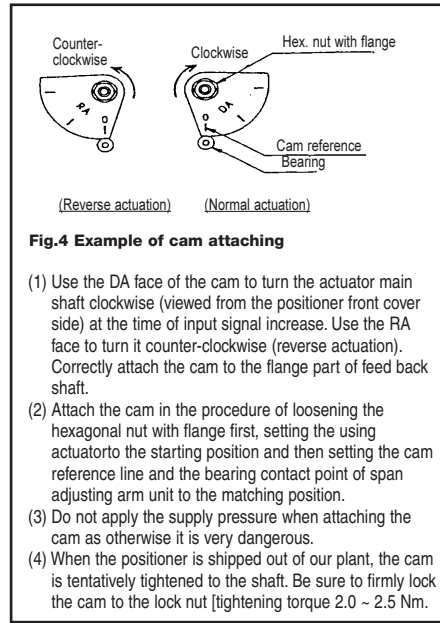

Fig.4 Example of cam attaching

- Use the DA face of the cam to turn the actuator main shaft clockwise (viewed from the positioner front cover side) at the time of input signal increase. Use the RA face to turn it counter-clockwise (reverse actuation). Correctly attach the cam to the flange part of feed back shaft.
- Attach the cam in the procedure of loosening the hexagonal nut with flange first, setting the using actuato to the starting position and then setting the cam reference line and the bearing contact point of span adjusting arm unit to the matching position.
- Do not apply the supply pressure when attaching the cam as otherwise it is very dangerous.
- When the positioner is shipped out of our plant, the cam is tentatively tightened to the shaft. Be sure to firmly lock the cam to the lock nut [tightening torque 2.0 ~ 2.5 Nm.

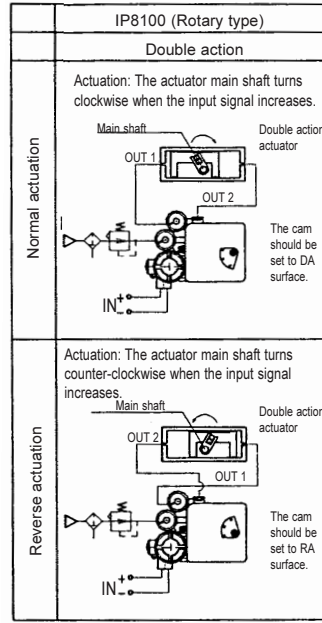

Fig.5 Direct / Reverse actuation

5 ADJUSTMENT

CAUTION

Check the following prior to start the adjustment.

- Check that the pipeline is correctly connected with the pressure supply port and OUT1 and OUT2 ports.
- Check that the actuator and positioner are sturdily connected.
- Check for locking of the auto/manual changeover screw of pilot valve (fully tightened in the clockwise direction).
- Check for correct use of the cam face (normal or reverse) in Type IP8100 and that the flange nut is firmly locked. (Refer to Fig.5)
- Check that the wires are connected correctly with the (+), (-) and grounding terminals.

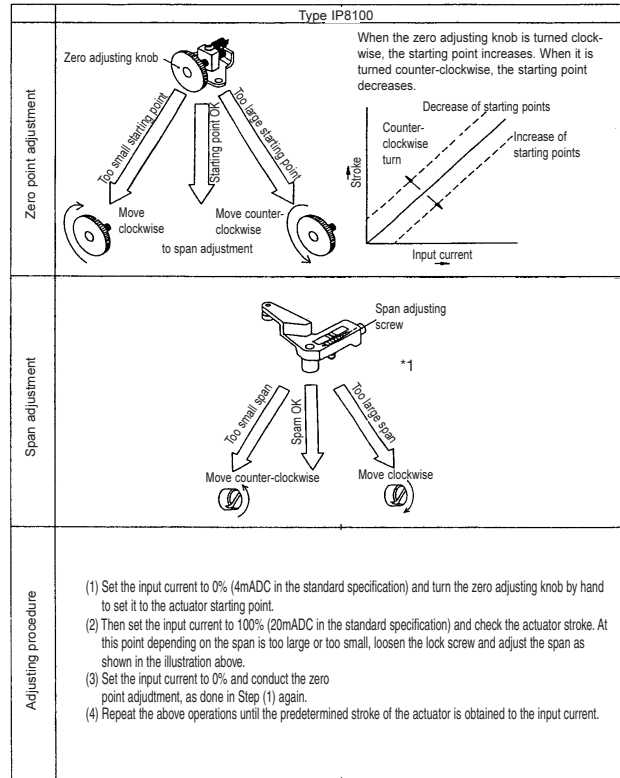

Fig.6 Zero / Span adjustment

*1 When the span adjusting screw is turned clock-wise with a slothead(-) screwdriver, the span decreases. When it is turned counter-clockwise, the span increases.

CAUTION

- For this positioner, span and zero point adjustment of each actuator is necessary. Adjustment shall be done based on each actuator size.
- Keep in mind that span and zero point adjustment interfere in each other.
- Characteristics changes due to change of mounting position, ambient temperature and supply pressure.
- If it takes along time until the operation after initial adjustment, check and adjust this product.
- Sensitive adjustment is effective for only double acting actuator.
- Manual change function is effective for single acting actuator which is controlled by using OUT1.

5.1 Electrical Wiring

This product has a potentiometer and p.c.board built into it. This is for confirming the actuator's opening by a 4-20mADC output signal produced by supplying initial power to the pcb. This supply power can be set freely between DC12-35V.

According to the operating direction of the actuator or feed back lever, the clockwise potentiometer direction gives regular operation, and the counter-clockwise direction gives opposite operation.

5.1.1 Wiring of Input signal & Power source

- Connect the input signal (for Positioner control) to 1(+) and 2(-) of the terminal board in the terminal box.
- Connect power source (for detecting output current) to 3(+) and 4(-) of the terminal board.
- Connect an ammeter in series between (+) side and 3(+) of terminal board or (-) side and 4(-).

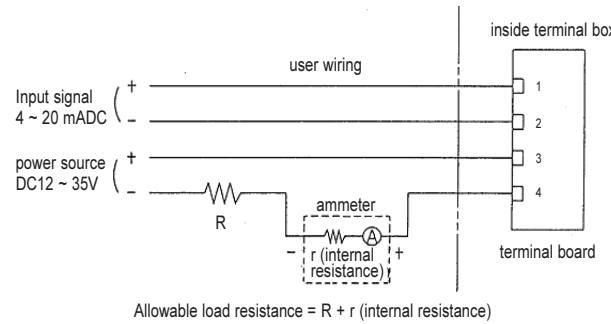

NOTE ! Allowable load resistance depends on supply voltage

- The allowable load resistance is obtained by the formula below.
Allowable load resistance ≤ (Supply voltage-12V) / 20mADC(-1)

Normal output current is not obtained if the load resistance value exceeds the results of the formula. Please confirm internal resistance when selecting an ammeter.

5.2 Zero / Span adjustment (output)

Zero point / Span adjustment of the output current of the positioner (with potentiometer) should be carried out after initial zero / span adjustments in Fig.6.

This product requires zero / span adjustment of the output current according to the actuator's rotating angle (Rotary type).

Please follow the procedure below.

- Set actuator's output opening or stroke to 0% after adjusting the zero / span.
- Adjust zero / span with the variable resistor on the p.c.board.
- Adjust zero point and span alternately and repeatedly as they interact with each other. Since this variable resistor can be wound endlessly, do not overwind otherwise internal equipment might be broken. Adjust while monitoring output signal.

5.3 Change of Operating direction (IP8100 Rotary)

- The Output signal is configured to increase in normal operation (clockwise) when shipped.
- To apply the positioner in reverse operation (counter-clockwise), specify the accessory classification JR when ordering. Alternatively, to change the operation of the delivered product, rearrange the cam to the opposite side and switch the terminals A and C (refer to Fig.7), to reverse the direction of the output signal.
- Loosen potentiometer set screw while applying power and ensuring output current, then rotate the potentiometer 10-20° away from the dead band (see Fig.8) to decide the start point. Settle the potentiometer with the screws again.

CAUTION

(Setting potentiometer)

- The Output signal does not operate at the dead band of the potentiometer.
- If the start point is set at 4mADC, the border line of resistance portion and the dead band, malfunction might occur.
- If the Output current is 0mADC during opening, the potentiometer may be set across the border between the resistance and the dead band. Follow step above noting the potentiometer rotation direction.
- When the rotary positioner is used in reverse action, adjust the potentiometer fixing position to avoid clashing of the cam and potentiometer lead wire.

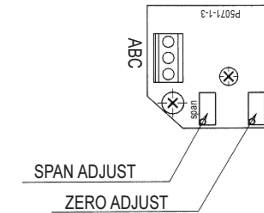

Fig.7 P.C. board

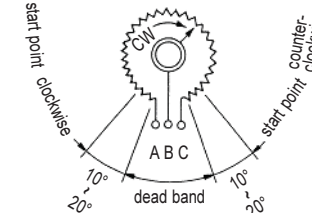

Fig.8 Potentiometer (IP8100)

6 MAINTENANCE

WARNING

- After installation, repair and disassembly, connect compressed air and perform a proper function test and leak test. If bleed noise is louder than the initial state, or operation is abnormal, stop operation and check if installation is correct or not.

CAUTION

- Check if supply air is clean or not. Inspect compressed air cleaning system periodically so that dust, oil and humidity, which can cause malfunction and failure of the unit, do not enter the equipment
- If handled improperly, compressed air can be dangerous. Maintenance and replacement of unit parts should only be performed by trained and experienced personnel for instrumentation equipment, as well as following the product specifications.
- Check the positioner once a year. When an excessively worn diaphragm, O-ring or other packing of any unit that has been damaged is found, replace with new ones. Treatment at an early stage is especially important if the positioner is used in a place of severe environment, such as coastal areas.
- Before removing the positioner for maintenance, or replacing unit parts after installation, ensure the supply pressure is shut off and all residual air pressure is released from the piping.
- When the fixed orifice is clogged with carbon particles or other material, remove the pilot valve Auto/Manual change over screw (built in fixed aperture) and clean it by inserting a 0.3mm diameter wire into the aperture.
- When you disassemble the pilot valve, coat the O-ring of the sliding section with grease. (Use the TORAY SILICONE SH45 grease.)
- Check for air leaks from the compressed air piping. Air leaks could lower the performance characteristics of the positioner. Air is normally discharged form a bleed port, but this is necessary air consumption based on the construction of the positioner, and is not an abnormality if the air consumption is within the specified range.

7 CONTACTS

To enquire about the product, please contact the following :-

SMC Corporation

AUSTRIA	(43) 2262-62 280	ITALY	(39) 02-92711
BELGIUM	(32) 3-355 1464	NETHERLANDS	(31) 20-531 8888
CZECH REP.	(420) 5-414 24611	NORWAY	(47) 67 12 90 20
DENMARK	(45) 70 25 29 00	POLAND	(48) 22-548 50 85
FINLAND	(358) 9-859 580	PORTUGAL	(351) 22 610 89 22
FRANCE	(33) 1-64 76 1000	SPAIN	(34) 945-18 4100
GERMANY	(49) 6103 4020	SWEDEN	(46) 8-603 0700
GREECE	(30) 1- 342 6076	SWITZERLAND	(41) 52-396 3131
HUNGARY	(36) 1-371 1343	TURKEY	(90) 212 221 1512
IRELAND	(353) 1-403 9000	UK	(44) 1908-56 3888

Websites

SMC Corporation
www.smworld.com

SMC Europe
www.smceu.com