



**Installation & Maintenance Manual**  
**Digital Pressure Switch**  
**Series ZSE30A(F)/ISE30A**



**Safety Instructions**

- This manual contains essential information for the protection of users and others from possible injury and/or equipment damage.
- Read this manual before using the product, to ensure correct handling, and read the manuals of related apparatus before use.
- Keep this manual in a safe place for future reference.
- These instructions indicate the level of potential hazard by label of DANGER, WARNING or CAUTION, followed by important safety information which must be carefully followed.
- To ensure safety of personnel and equipment the safety instructions in this manual and the product catalogue must be observed, along with other relevant safety practices.

<b>⚠ DANGER</b>	In extreme conditions, there is a possible result of serious injury or loss of life.
<b>⚠ WARNING</b>	If instructions are not followed there is a possibility of serious injury or loss of life.
<b>⚠ CAUTION</b>	If instructions are not followed there is a possibility of injury or equipment damage.

**⚠ WARNING**

- **Do not disassemble, modify (including change of printed circuit board) or repair the product.**  
An injury or product failure may result.
- **Do not operate the product beyond the specification range.**  
Fire, malfunction or equipment damage may result. Use the product only after confirming the specifications.
- **Do not use the product in the presence of flammable, explosive or corrosive gas.**  
Fire, explosion or corrosion may result. This product does not have an explosion proof construction.
- **When using the product as part of an interlocking system:**  
1) Provide a double interlocking system, for example a mechanical system.  
2) Check the product regularly to ensure proper operation.
- **Before performing maintenance, be sure of the following:**  
1) Turn off the power supply.  
2) Stop the air supply, exhaust the residual pressure and verify the release of air from the system.

**⚠ CAUTION**

- **Always perform a system check after maintenance.**  
Do not use the product if any error occurs.  
Safety cannot be assured if caused by un-intentional malfunction.
- **Provide grounding to ensure correct operation and to improve noise resistance of the product.**  
This product should be individually grounded using a short cable.

**Safety Instructions (continued)**

- **Power Supply selection**  
Use a UL approved direct current (DC) power supply with this product. Use a power supply (class 2) which is of 30Vrms (42.4V peak) or less, complying with UL1310, or a supply circuit with transformer (class 2) complying with UL1585.

**NOTE**

Follow the instructions given below when handling the pressure switch. Otherwise, the pressure switch may be damaged or may fail, thereby resulting in malfunction.

- Make sure to use the pressure switch within the specified voltage range.
- Make sure to use the pressure switch within operating pressure range.
- Data input to the pressure switch is not deleted even if the power supply is disconnected.
- Prepare maintenance space around the product.
- Do not drop or bump, or apply excess impact to the product (100m/s<sup>2</sup>).
- Do not pull the lead wire forcefully, or lift the pressure switch by pulling the lead wire. (Tensile force 35N or less)
- Mount the pressure switch using the correct tightening torque.
- For piping of the pressure switch, hold the piping with a spanner on the metal part of the piping (Piping attachment).
- Install the pressure switch after eliminating dust from the piping by cleaning with a blast of air to avoid failure and malfunction.
- Never mount the pressure switch in a place that will be used as a foothold during piping.
- If the air used contains condensate, install an air dryer and drain before a filter and release the condensate regularly. If a lubricator is used, install the pressure switch at the primary side of the lubricator (flow inlet).
- If foreign material is possible in the fluid, install a filter or mist separator on the inlet side of the pressure switch to avoid failure and malfunction.
- Do not use the pressure switch with corrosive and flammable gas.
- Avoid repeatedly bending or stretching the lead wire.
- Wire correctly.
- Do not wire while the power is ON.
- Do not route the wire in the same place as power cables or high voltage cables.

- Confirm proper insulation of wiring.
- Wire as short as possible to avoid the effect of noise and surge.
- Only the pressure switch with UL mark on the body is UL approved product.
- Do not use in an area where magnetic field is generated to avoid malfunction of the pressure switch.
- Do not use in an area containing oil or chemicals.
- Do not apply heat cycle to the pressure switch.
- Do not use in an area where surges are generated.
- The pressure switch is not equipped with surge protection against lightning.
- Do not use a load which generates surge voltage.
- Avoid foreign matters such as wiring chips from entering the pressure switch.
- Consider the operating environment according to enclosure IP rating.
- Do not mount the pressure switch where vibration and impact exist to avoid failure and malfunction.
- Operation under low temperature (5°C or less) can cause damage or operation failure due to frozen moisture in the fluid or air.
- Do not short-circuit the load. It can cause failure and malfunction.
- Do not press the set buttons with sharp pointed object.
- The pressure switch will not operate for 4 seconds after power is supplied.
- Maintenance and inspection should be performed periodically.
- Displayed analogue output may fluctuate by 2 to 3% for 10 minutes after supplying the power to the pressure switch.
- Do not poke inside a piping port with a sharp object.
- Do not touch the LCD display during operation.

**Model Indication Method**

ISE30A - 01 - N

Set pressure range

	Symbol	Content
Positive pressure	ISE30A	-0.1 to 1MPa
Vacuum pressure	ZSE30A	0 to -101kPa
Compound pressure	ZSE30AF	-100 to 100kPa

Piping specification

Symbol	Content
01	R1/8 (with M5 female thread)
* N01	NPT1/8 (with M5 female thread)
C4H	One-touch fitting φ 4mm and φ 5/32 inch (Straight type)
C6H	One-touch fitting φ 6mm (Straight type)
N7H	One-touch fitting φ 1/4inch (Straight type)
C4L	One-touch fitting φ 4mm and φ 5/32 inch (Elbow type)
C6L	One-touch fitting φ 6mm (Elbow type)
N7L	One-touch fitting φ 1/4inch (Elbow type)

\* made to order

Output specification

Symbol	Content
N	NPN open collector 1 output
P	PNP open collector 1 output
A	NPN open collector 2 outputs
B	PNP open collector 2 outputs
* C	NPN open collector 1 output + Analogue voltage output
* D	NPN open collector 1 output + Analogue current output
* E	PNP open collector 1 output + Analogue voltage output
* F	PNP open collector 1 output + Analogue current output

\* made to order

**Specification**

Model No.	ZSE30A (Vacuum)	ZSE30AF (Compound)	ISE30A (Positive pressure)	
Rated pressure range	0.0 to -101.0kPa	-100.0 to 100.0kPa	-0.100 to 1.000MPa	
Set pressure range	10.0 to -105.0kPa	-105.0 to 105.0kPa	-0.105 to 1.050MPa	
Withstand pressure	500kPa	500kPa	1.5MPa	
Min. display unit	0.1kPa	0.1kPa	0.001MPa	
Applicable fluid	Air, inert gases and incombustible gases			
Power supply voltage	12 to 24VDC ±10%, ripple (p-p) 10% or less (Protected against reverse connection)			
Current Consumption	40mA or less			
Switch Output	NPN or PNP open collector output 1 output NPN or PNP open collector output 2 outputs (selectable)			
	Max. load current	80mA		
	Max. applied voltage	28V (NPN output)		
	Residual voltage	1V or less (at 80mA load current)		
	Response time	2.5ms or less (with anti-chatter function: 20, 100, 500, 1000 or 2000ms selectable)		
Analogue output	Output protection Short circuit protection			
	Voltage output (Note 2)	Output voltage	1 to 5V ±2.5%F.S. / 0.6 to 5V ±2.5%F.S.	
		Linearity	±1%F.S. or less	
	Current output (Note 3)	Output impedance	Approx. 1kΩ	
		Output current	4 to 20mA ±2.5%F.S.	2.4 to 20mA ±2.5%F.S.
Linearity		±1%F.S. or less		
Load impedance	Max. load impedance: 300Ω (at power supply voltage of 12VDC) 600Ω (at power supply voltage of 24VDC)			
	Min. load impedance: 50Ω			

**Model Indication Method (continued)**

Option 3

Symbol	Operation manual		Calibration certificate
	Booklet	CD-ROM	
Nil	○	-	-
Y	-	-	-
W	-	○	-
K	○	-	○
T	-	-	○
R	-	○	○

Option 2

Symbol	Content
Nil	No option
A1	Bracket A
A2	Bracket B
B	Panel mount adapter
D	Panel mount adapter + Front protective cover

Option 1

Symbol	Content
Nil	Without lead wire
L	With lead wire and connector (length 2m) Note 1)
G	With lead wire and connector (length 2m) and connector cover Note 1)

Note 1) The output specification "N" or "P" is equipped with 3 cores lead wire, and 4 cores lead wire for others.

**Unit specification**

Symbol	Content
Nil	With unit conversion function Note 1)
M	Fixed SI unit Note 2)
* P	With unit conversion function (PSI initial value) Note1)

\* made to order  
 Note 1) The new Measurement Law prohibits the use of pressure switch with the unit conversion function in Japan.  
 Note 2) Fixed unit kPa, MPa

**Specification (continued)**

Model No.	ZSE30A (Vacuum)	ZSE30AF (Compound)	ISE30A (Positive pressure)
Repeatability	±0.2%F.S. ±1digit		
Hysteresis	Variable from 0 Note 1)		
Display method	4digits 7-segment display, dual-colour display (red/green)		
Indicator accuracy	±2%F.S. ±1digit (at ambient temperature 25 ±3 °C)		
Indicator	LED lit when ON OUT1: Green OUT2: Red		
Environment	Enclosure	IP40 (IEC60529)	
	Ambient temperature	Operation: 0 to 50 °C, Storage: -10 to 60 °C (No condensation or freezing)	
	Ambient humidity	Operation, Storage: 35 to 85%RH (No condensation)	
	Withstand voltage	1000VAC, 1 minute (between connections and case)	
	Insulation resistance	50MΩ or more at 500VDC (between connections and case)	
Vibration proof	10 to 150Hz smaller one 1.5mm or 20m/s <sup>2</sup> double amplitude each in directions of X, Y and Z for 2 hours (De-energizing)		
	Impact proof 100m/s <sup>2</sup> 3 times each in directions of X, Y and Z resp. (De-energizing)		
Temperature characteristic	±2%F.S. (25 °C reference)		
Lead wire	Oil resistance vinyl cabtyre cable 3 cores φ 3.5 2m 4 cores Sectional area of conductor: 0.15mm <sup>2</sup> (AWG26)		
Standard	CE UL/CSA RoHS		

Note 1) If the applied voltage fluctuates around the set value, the set hysteresis must exceed the fluctuation width. Otherwise, chattering will occur.  
 Note 2) If analogue voltage output is selected, the analogue current output cannot be selected at the same time.  
 Note 3) If analogue current output is selected, the analogue voltage output cannot be selected at the same time.

**Specification (continued)**

**Piping specifications**

Model	O1	N01	C4H	C6H	N7H
Port size	R1/8 M5×0.8	NPT1/8 M5×0.8	-	-	-
One-touch fitting straight type	-	-	φ4mm φ5/32inch	φ6mm	φ1/4inch
One-touch fitting elbow type	-	-	-	-	-
Pressure sensing part	Pressure sensing part: Silicone				
Piping port	C3602 (Electroless nickel plating) O-ring: HNBR		PBT, POM, SUS304, C3604 (Electroless nickel plating) O-ring: NBR		
Weight					
With connector, including lead wire (3-core, 2m)	81g		70g	71g	73g
With connector, including lead wire (4-core, 2m)	85g		74g	75g	77g
With connector, excluding lead wire	43g		32g	33g	35g

Model	C4L	C6L	N7L
Port size	-	-	-
One-touch fitting straight type	-	-	-
One-touch fitting elbow type	φ4mm φ5/32inch	φ6mm	φ1/4inch
Pressure sensing part	Pressure sensing part: Silicone		
Piping port	PBT, POM, SUS304, C3604 (Electroless nickel plating) O-ring: NBR		
Weight			
With connector, including lead wire (3-core, 2m)	75g	73g	75g
With connector, including lead wire (4-core, 2m)	79g	77g	79g
With connector, excluding lead wire	37g	35g	37g

**Analogue output**

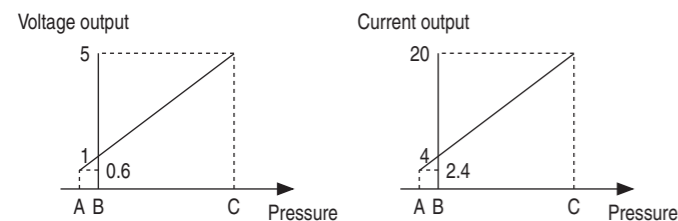

Range	Rated pressure range	A	B	C
For vacuum	0.0 to -101.0kPa	-	0	-101kPa
For compound	-100.0kPa to 100.0kPa	-	-100kPa	100kPa
For positive pressure	-0.100 to 1.000MPa	-0.1kPa	0	1MPa

**Outline with Dimensions (mm)**

**Body dimensions**

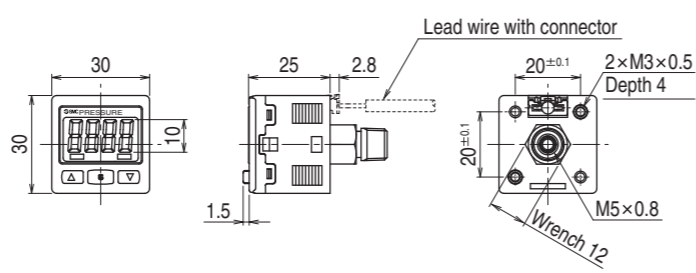

**O1/N01 type**

O1: R1/8  
N01: NPT1/8

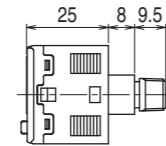

**C4H type**

One-touch fitting  
φ4mm, φ5/32inch  
For straight

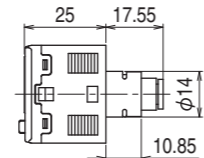

**C6H type**

One-touch fitting  
φ6mm  
For straight

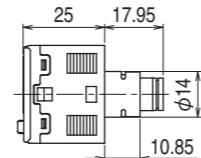

**N7H type**

One-touch fitting  
φ1/4inch  
For straight

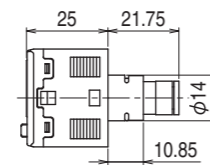

**C4L type**

One-touch fitting  
φ4mm, φ5/32inch  
For elbow

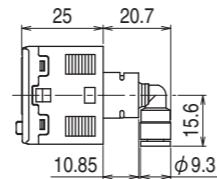

**C6L type**

One-touch fitting  
φ6mm  
For elbow

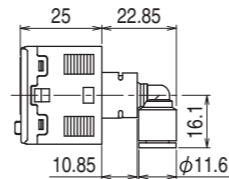

**N7L type**

One-touch fitting  
φ1/4inch  
For elbow

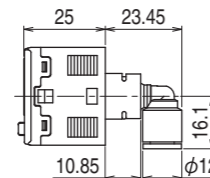

**Outline with Dimensions (mm) (continued)**

**Bracket A (ZS-38-A1)**

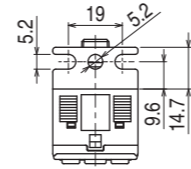
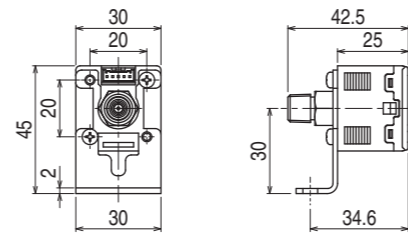

**Bracket B (ZS-38-A2)**

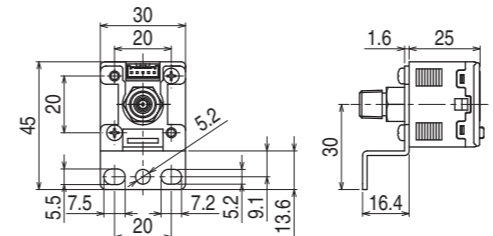
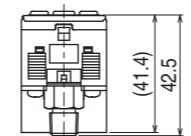

**Panel mount adaptor (ZS-27-C)**

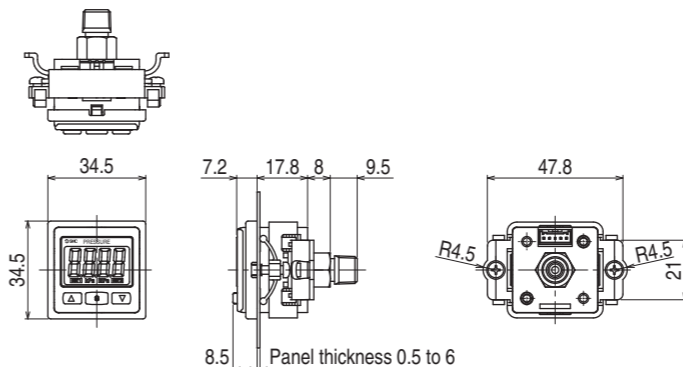

**Panel mount adaptor + Front protective cover (ZS-27-D/ZS-27-C+ZS-27-01)**

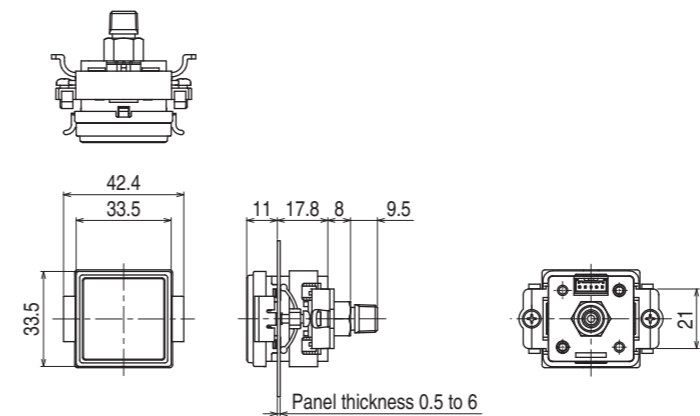

**Names and Functions of Individual Parts**

**Main Unit**

Indication light (Green OUT1 and Red OUT2): Displays switch operation condition.

LCD display: Displays the current status of pressure, setting mode, selected indication unit and error code. Four display modes can be selected: display always in red or green only, or changing from green to red, red to green linked to output.

- ▲ button: Alters the mode or increases ON/OFF set value. Press this button to change to the peak display mode.
- ▼ button: Alters the mode or decreases ON/OFF set value. Press this button to change to the bottom display mode.
- S button: Press this button to change to either mode and to set a set value.

Unit indication: Displays the current specification of unit. (Only for kPa and MPa indication unit)

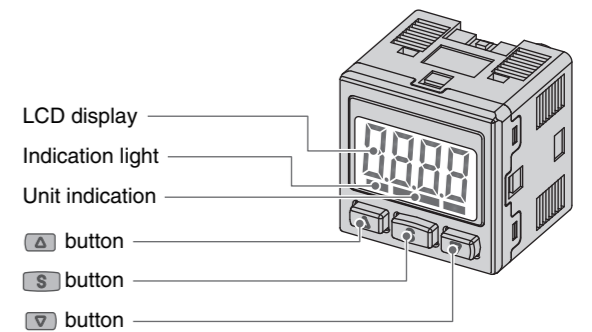

**Mounting and Installation**

**Installation**

**Mounting with bracket**

Note) The tightening torque of piping port must be 7 to 9 N·m. The tightening torque of the bracket mounting screw must be 0.5 to 0.7N·m.

- Mount the bracket on the pressure switch with the set screws M3×5L (2 pcs.) supplied.

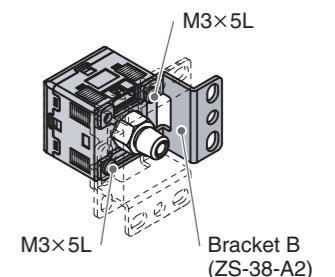
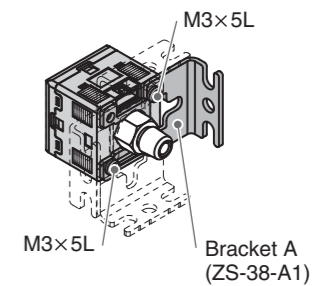

**Mounting and Installation (continued)**

**Mounting with panel mount adapter**

- Fix the panel mount adapter to the pressure switch with the set screws M3×8L (2 pcs.) supplied.

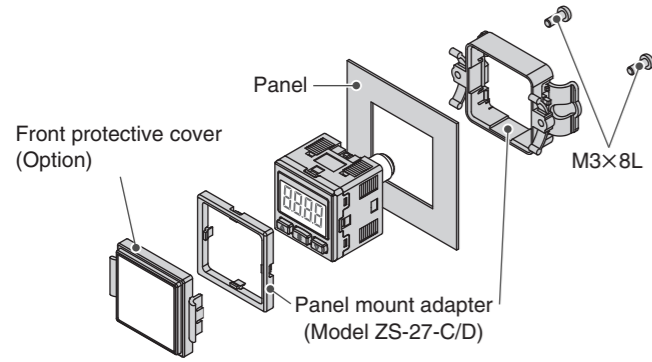

\* The panel mount adapter can be rotated by 90 degrees for mounting.

**Notice when removing the switch**

- The pressure switch with the panel mount adapter can be removed from the installation by opening the hooks each side of the switch, after removing the screws. Take care not to damage the pressure switch or panel mount adapter during removal.

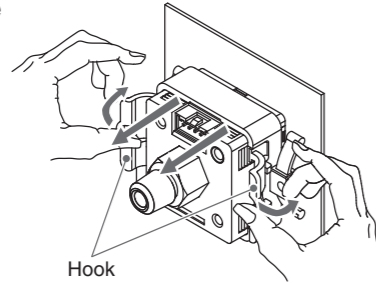

- Panel cutout dimension  
Panel Thickness 0.5 to 6mm

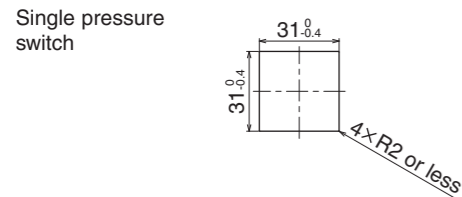

- Two or more in a row  
n : The number of the pressure switches  
<Horizontal>

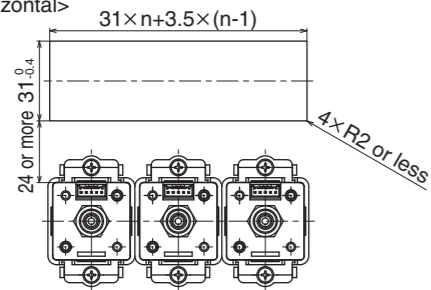

- <Vertical>

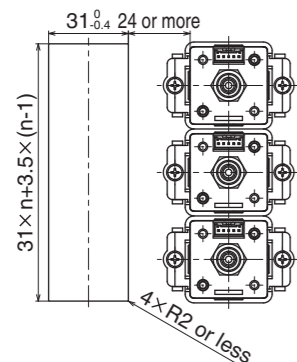

**Mounting and Installation (continued)**

**Piping with One-touch fitting**

- Cut the tube perpendicularly.
- Hold the tube and insert it into the One-touch fitting slowly until it will bottom out.

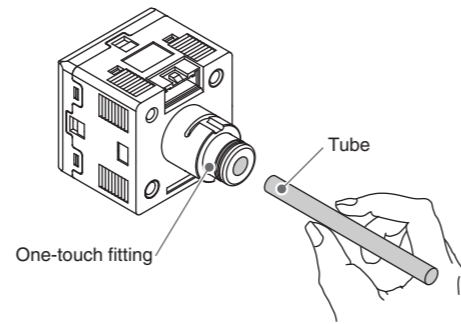

**WARNING**

**Do not install the pressure switch in a place where electrical static charge will be a problem.**  
It may cause an error or system damage.

- Allow a tolerance for the tube length to prevent twist, tensile or moment loads from being applied to the fitting and tube.
- When using a tube not manufactured by SMC, ensure that the outside diameter accuracy satisfies the following tolerances.
  - Nylon tube: ±0.1mm max.
  - Soft nylon tube: ±0.1mm max.
  - Polyurethane tube: +0.15mm / -0.2mm max.

**Wiring**

**Connection**

- Make wiring connection with the power off.
- Use a separate route for wires to the pressure switch. Malfunction due to noise may occur if the wire is installed in the same route as that of power or high-voltage cable.
- Be sure to ground terminal FG when using a switch-mode power supply obtained on the market. When the switch-mode power supply is connected to the pressure switch, switching noise will be superimposed and product specification can no longer be met. This can be prevented by inserting a noise filter, such as a line noise filter and ferrite core, between the switch-mode power supply and the pressure switch, or by using a series power supply instead of the switch-mode power supply.

**Connector**

- When mounting the connector, insert it straight into the pins holding the lever and connector body and press the lever hook firmly into the groove in the housing to lock.
- When removing the connector, press down the lever to release the hook from the groove and pull the connector straight out.

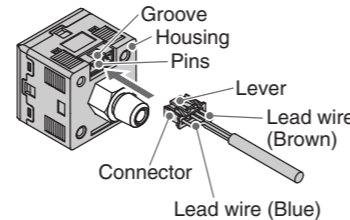

**Connector Pin No.**

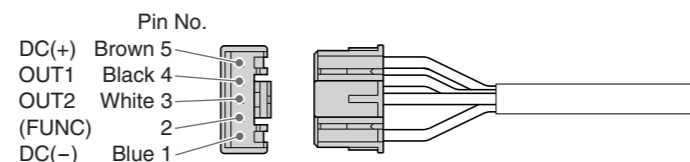

**Mounting and Installation (continued)**

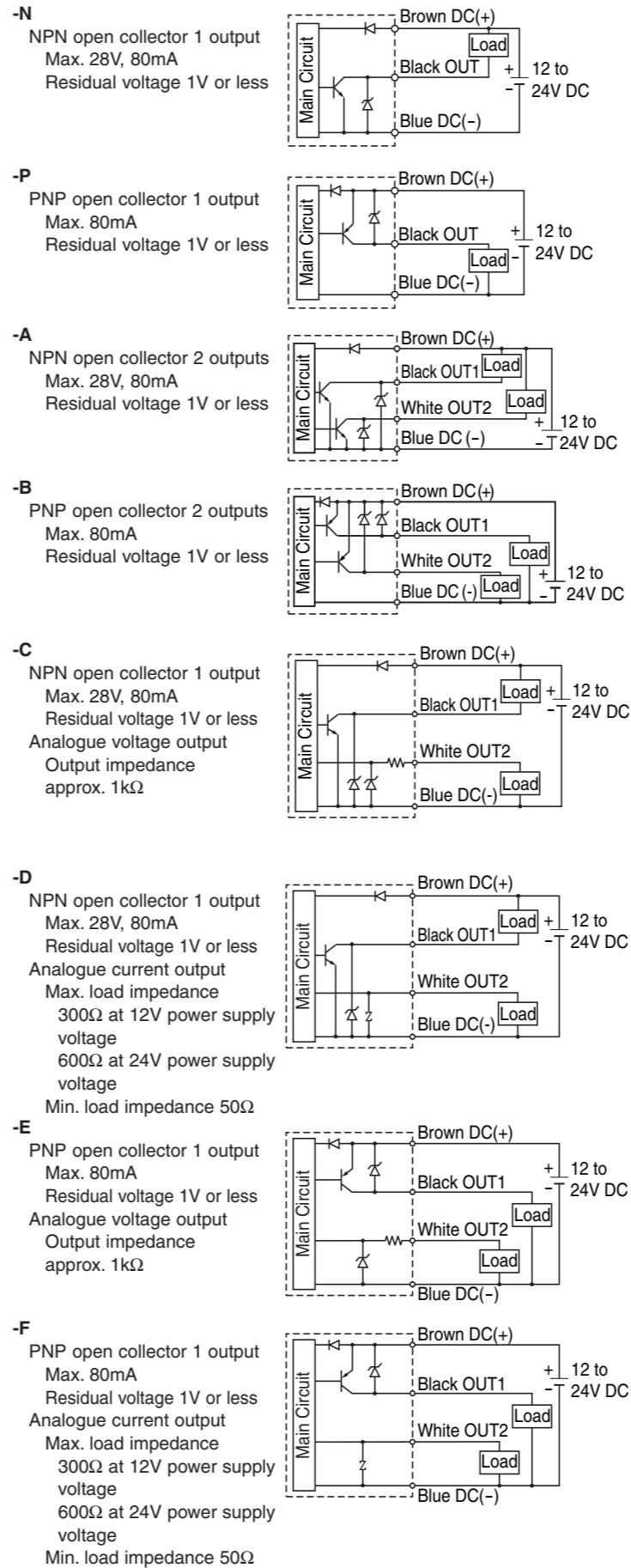

**Pressure Setting**

Set ON point and OFF point of the pressure switch.

**Operation**

When the pressure exceeds the set point, the pressure switch will be turned on.

When the pressure falls below the set point by the amount of hysteresis or more, the pressure switch will be turned off.

The default setting of output set value is the midpoint value between atmospheric pressure and upper limit of the rated pressure range.

If the operation shown below does not cause any problem, keep the settings.

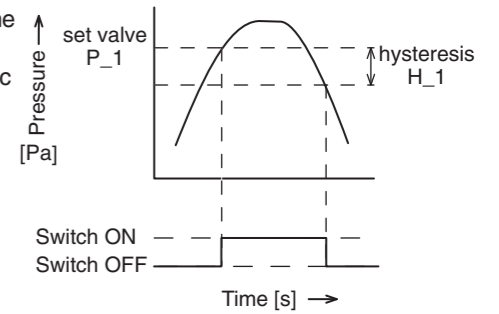

**<How to operate>**

- Press the button once in measurement mode.



- [P\_1] and set value are displayed in turn.



- Press the or button to change the set value. The button is for increase and the button is for decrease.

- Press the button once to increase by one digit, and press it continuously to keep increasing.

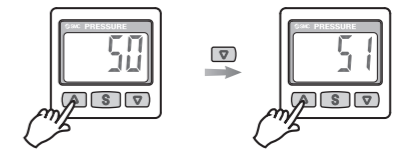

- Press the button once to decrease by one digit, and press it continuously to keep decreasing.

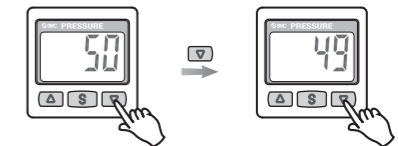

- Press the button to finish the setting. If 2 outputs specification is selected, [P\_2] is displayed. Continue the setting operation.

The pressure switch moves within a set pressure range (from P1L to P1H) during window comparator mode. Set P1L (switch lower limit) and P1H (switch upper limit) with the setting procedure above.

**Zero clear of display**  
Display is reset to zero when and buttons are pressed simultaneously for 1 second.  
For the first operation, perform zero clear without pressure supply.

**Setting of Function**

■ **Default setting**

At the time of shipment, the following default settings are provided.

If this setting is acceptable, keep it for use.

● [F 1] Parameter setting of OUT1

Item	Explanation	Default setting
Output mode	Selects hysteresis mode or window comparator mode.	Hysteresis mode
Reversed output	Selects reversed output	Normal output
Pressure setting	Sets ON point or OFF point of the switch output	ISE30A: 0.500MPa ZSE30A: -50.5kPa ZSE30AF: 50.0kPa
Hysteresis	Chattering can be prevented by setting hysteresis.	5%
Display colour	Selects the display colour.	ON: Green OFF: Red

● [F 2] Parameter setting of OUT2

Same setting as [F 1] OUT1.  
Display colour is linked to the setting of OUT1, and can not be selected.

Item	Default setting
[F 0] Unit conversion function	ISE: MPa ZSE: kPa Option1="P": psi
[F 3] Setting of response time	2.5ms
[F 4] Setting of display resolution	1000-split
[F 5] Setting of auto-preset	Manual
[F 6] Setting of fine adjustment of display value	0%
[F 7] Setting of power saving mode	OFF
[F 8] Setting of security code	OFF

**Measurement mode**

The measurement mode is the condition where the pressure is detected and indicated, and the pressure switch function is operating.

This is the basic mode and is moved to another mode for setting change and other function setting depending on purpose.

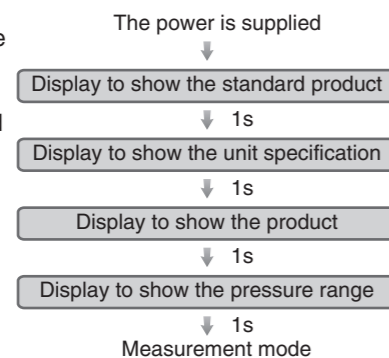

**Setting of Function (continued)**

**Function selection mode**

In measurement mode, press the **[S]** button for 2 seconds or longer to display [F 0]. Select the display of function setting to be changed, [F□□].

Press the **[S]** button for 2 seconds or longer in function selection mode to return to measurement mode.

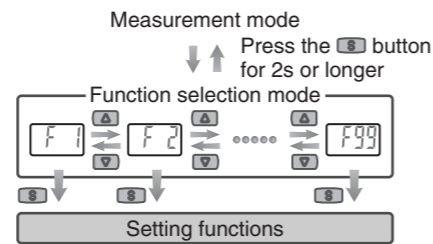

Note) Some functions are not available depending on part number. All functions are displayed with [F□□] and followed with function description. If a function is not available for specified type, the function is displayed as [--].

**Error Indication**

**Error indication function**

This function is to display error location and content when a problem or an error occurs.

Error Name	Error Display	Error Nature	Troubleshooting Method
Over current Error	Er 1 Er 2	A load current of switch output of 80mA or more is flowing.	Turn the power off and remove the output factor for the over current. Then turn the power on.
Residual Pressure Error	Er 3	During zero clear operation, pressure over ±7%F.S. (±3.5%F.S. for compound pressure) is applied. In 1 second, the mode will reset to the measurement mode. ±1%F.S. of the zero clear range changes with individual product differences.	Perform zero clear operation again after restoring the applied pressure to an atmospheric pressure condition.
Pressurizing Error	HHH	Pressure exceeding the high limit of the set pressure range is applied.	Reset applied pressure to a level within the set pressure range.
	LLL	Pressure exceeding the low limit of the set pressure range is applied.	

Error Name	Error Display	Error Nature	Troubleshooting Method
System Error	Er 0 Er 4 Er 6 Er 7 Er 8 Er 9	Displayed in the case of an internal data error.	Turn the power off and turn it on again. If resetting fails, an investigation by SMC CORPORATION will be required.

If the error can not be reset after the above measure is taken, please consult with SMC.

**Contact**

AUSTRIA	(43) 2262 62280	NETHERLANDS	(31) 20 531 8888
BELGIUM	(32) 3 355 1464	NORWAY	(47) 67 12 90 20
CZECH REP.	(420) 541 424611	POLAND	(48) 22 211 9600
DENMARK	(45) 7025 2900	PORTUGAL	(351) 21 471 1880
FINLAND	(358) 207 513513	SLOVAKIA	(421) 2 444 56725
FRANCE	(33) 1 6476 1000	SLOVENIA	(386) 73 885 412
GERMANY	(49) 6103 4020	SPAIN	(34) 945 184 100
GREECE	(30) 210 271 7265	SWEDEN	(46) 8 603 1200
HUNGARY	(36) 23 511 390	SWITZERLAND	(41) 52 396 3131
IRELAND	(353) 1 403 9000	UNITED KINGDOM	(44) 1908 563888
ITALY	(39) 02 92711		

**SMC Corporation**

URL <http://www.smcworld.com> (Global) <http://www.smceu.com> (Europe)

Specifications are subject to change without prior notice from the manufacturer.  
© SMC Corporation All Rights Reserved.