



# Installation & Maintenance Manual

## Digital Flow Switch

- For Air Series **PF2A710/750**  
**PF2A711/721/751**
- For Water Series **PF2W704/720/740**  
**PF2W711**  
**PF2W704T/720T/740T**



### Safety Instructions

The Digital Flow Switch and this manual contain essential information for the protection of users and others from possible injury and property damage and to ensure correct handling. Please confirm that you fully understand the definition of the following messages (signs) before going on to read the text, and always follow the instructions. Please read and understand the operation manuals of related apparatus before operating the flow switch.

#### IMPORTANT MESSAGES

Read this manual and follow its instructions. Signal words such as WARNING, CAUTION and NOTE, will be followed by important safety information that must be carefully reviewed.

<b>⚠WARNING</b>	Indicates a potentially hazardous situation which could result in death or serious injury if you do not follow instructions.
<b>⚠CAUTION</b>	Indicates a potentially hazardous situation which if not avoided, may result in minor injury or moderate injury.
<b>NOTE</b>	Gives you helpful information.

#### ⚠WARNING

**Do not disassemble, modify (including change of printed circuit board) or repair.**

An injury or failure can result.

**Do not operate outside of the specification.**

Fire, malfunction or switch damage can result. Please use it after confirming the specification.

**Do not operate in an environment of inflammable, explosive or corrosive gas.**

Fire or an explosion can result.

This flow switch is not an explosion proof type.

### Safety Instructions (continue)

#### ⚠WARNING

Prepare a double interlock using another system (Mechanical interlock, etc.), and check it is operating correctly, when using this product in an interlock circuit.

An accident by a malfunction may potentially result.

**Do not use with an inflammable, an explosive or a combustible fluid.**

Otherwise, a fire or an explosion or damage may potentially result. (The detector of the flow switch for air is heated to 150°C)

#### ⚠CAUTION

**Check for fluid leakage after installing the flow switch.**

Neglecting fluid leakage may cause a burn or damage to the machines and equipment. A burn may occur when using a high temperature model for water.

**Do not touch the pipe joining parts. (High temperature applications for water)**

Otherwise, a burn may occur. Touch after confirming the product has sufficiently cooled.

#### NOTE

Follow the instructions given below when handling the flow switch. Otherwise, the switch may be damaged or may fail, thereby resulting in malfunction.

- Do not drop, bring into collision with other objects or apply excessive shock to the unit (490m/s<sup>2</sup> or more).
- Do not pull the lead wire with force or lift the main unit by holding the lead wire. (Pulling strength less than 49N)
- Connect wires and cables correctly.

- Do not perform wiring while power is on.
- Although the flow switch complies with the CE Marking, it does not have lightning surge protection, therefore please apply the necessary protection to the equipment.
- Although the flow switch complies with the CE Marking, it should be protected against any sources of surge (electro-magnetic lifter, high frequency induction furnace, motors etc.) around the flow switch.
- Do not use with power cable or high-voltage cable in the same wire route.
- Do not use in a place in which oil or chemical splashes may occur.
- Do not press the setting buttons with a sharp pointed object.
- Turn on the power supply of a flow switch for Air, when the flow is zero. Some initial drift occurs during ten minutes after turning the power on.
- For 3 seconds after power is turned ON the measurement output will be OFF. This includes after momentary disconnection of the power, by reset etc.) Please program the equipment to correspond to this.
- During initial setting or when setting the flow switch, the measured output continues to change with the flow measurement as before setting. Please check how this will affect the equipment before use. Check the flow switch set up after a control system is shut down, if required.
- Install a filter on the primary side (inlet side) if foreign matter is feared to mix in the fluid.
- Use the flow switch within the specified operating pressure range. Design the piping and switch setting (for water) so that the flow switch is not subjected to pressures outside the specified range by a water hammer, etc.
- Do not attach the flow switch (for air) with the underneath of the body facing upwards.

### Model Indication Method

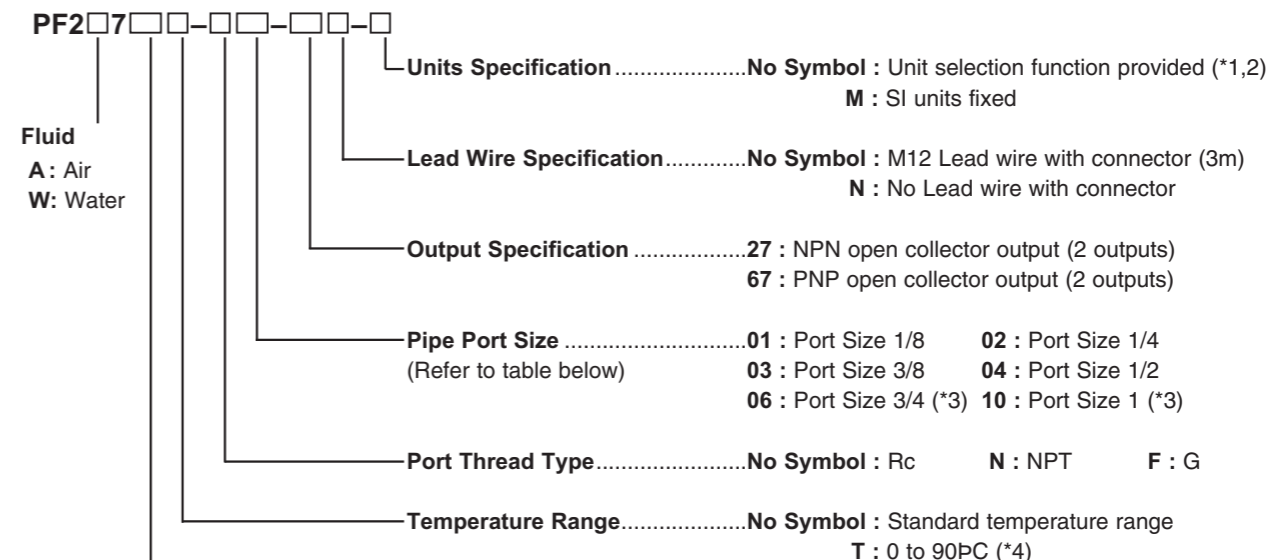

Type	Flow Rate	Pipe Port Size
PF2A 7	<b>10:</b> 1 to 10 ℓ /min	<b>01, 02</b>
	<b>50:</b> 5 to 50 ℓ /min	<b>01, 02</b>
	<b>11:</b> 10 to 100 ℓ /min	<b>03</b>
	<b>21:</b> 20 to 200 ℓ /min	<b>03</b>
PF2W 7	<b>51:</b> 50 to 500 ℓ /min	<b>04</b>
	<b>04:</b> 0.5 to 4 ℓ /min	<b>03</b>
	<b>20:</b> 2 to 16 ℓ /min	<b>03, 04</b>
	<b>40:</b> 5 to 40 ℓ /min	<b>04, 06</b>
	<b>11:</b> 10 to 100 ℓ /min	<b>06, 10</b>

#### NOTES

- \*1 : The new Measurement Law prohibits use in Japan of flow switches with a unit selection function.
- \*2 : Fixed unit for instantaneous flow rate is : ℓ /min for integrated flow rate is : ℓ
- \*3 : This Pipe Port Size is available with PF2W for water only.
- \*4 : The High Temperature Range is available with PF2W for water only.

### Specification

#### For Air

Model	PF2A 710	PF2A 750	PF2A 711	PF2A 721	PF2A 751
Fluid to be Measured	Air, Nitrogen				
Flow Rate Indication Range	0.5 to 10.5 ℓ/min	2.5 to 52.5 ℓ/min	5 to 105 ℓ/min	10 to 210 ℓ/min	25 to 525 ℓ/min
Set Flow Rate Range	0.5 to 10.5 ℓ/min	2.5 to 52.5 ℓ/min	5 to 105 ℓ/min	10 to 210 ℓ/min	25 to 525 ℓ/min
Rated Flow Range	1 to 10 ℓ/min	5 to 50 ℓ/min	10 to 100 ℓ/min	20 to 200 ℓ/min	50 to 500 ℓ/min
Operating Pressure Range	-50kPa to 0.5MPa		-50kPa to 0.75MPa		
Minimum Set Unit	0.1 ℓ/min	0.5 ℓ/min	1 ℓ/min	2 ℓ/min	5 ℓ/min
Flow rate conversion value	0.1 ℓ/pulse (Pulse width: 50msec)	0.5 ℓ/pulse (Pulse width: 50msec)	1 ℓ/pulse (Pulse width: 50msec)	2 ℓ/pulse (Pulse width: 50msec)	5 ℓ/pulse (Pulse width: 50msec)
Unit	ℓ/min, CFM×10 <sup>-2</sup>		ℓ/min, CFM×10 <sup>-1</sup>		
(*1, 2) Integrated Flow Rate	ℓ, ft <sup>3</sup> ×10 <sup>-1</sup>				
Operating Fluid Temperature	0 to 50°C				
Linearity	±5%F.S. or less				
Repeatability	±1%F.S. or less		±2%F.S. or less		
Temperature Characteristic	±3%F.S. or less (15 to 35°C, 25°C standard) ±5%F.S. or less (0 to 50°C, 25°C standard)				
Current Consumption (No load)	150mA or less		160mA or less		170mA or less
Mass (Weight) (*3)	250g		290g		
Piping Specification	1/8, 1/4		3/8		1/2
Material of Wet Part	Attachment: ADC Packing: NBR Mesh: SUS Internal Body: PBT Sensor-housing: PBT Sensor: Lead-glass/ PtIr/ FeNi/ OFC		Attachment: ADC Packing: NBR Spacer: PBT Mesh: SUS Internal Body: PBT Sensor-housing: PBT Sensor: Lead-glass/ PtIr/ FeNi/ OFC		

- \*1: With units selection function (Without units selection function, fixed to SI units (ℓ/min or ft<sup>3</sup>))
- \*2: Two units in normal condition (0°C/101.3kPa) or standard condition (20°C/101.3kPa/65%RH) can be selected.
- \*3: Lead wire not included.
- \*4: Select either switch output or pulse output of integrated flow rate at the initial setting.
- \*5: Window Comparator mode. Hysteresis (H) will be 3 digits. Separate [P\_1] and [P\_2], or [n\_1] and [n\_2], more than 7 digits. (In case of the output 2, n\_1,2 becomes n\_3,4 and P\_1,2 becomes P\_3,4)
- \*6: The flow switch conforms entirely to the CE standard.

Common Specification	
Detecting Method	Calorimetry
Displayed Digits	3 digits 7-segment LED
Withstand Pressure	1.0MPa
Integrated Flow Rate Range	0 to 999999 ℓ
Ambient Temperature Range	Operation: 0 to 50°C, Storage: -25 to 85°C (No condensation or Freezing)
Output Specification (*4)	NPN Open Collector Maximum Load Current: 80mA, Internal Voltage Drop: 1V or less (@ load current 80mA) Maximum Input Voltage: 30V 2 outputs
	PNP Open Collector Maximum Load Current: 80mA, Internal Voltage Drop: 1.5V or less (@ load current 80mA) 2 outputs
Operation Indicator Lamp	Lit when Output is ON, (OUT1): Green, (OUT2): Red
Response Time	1sec or less
Hysteresis	Hysteresis Mode: Variable (Settable starting 0), Window Comparator Mode (*5): Fixed (3 units)
Power Supply Voltage	12 to 24VDC, ripple ±10% or less
Withstand Voltage	1000VAC 1 minute Between group of external terminals and case
Insulation Resistance	50MΩ or more (@ 500VDC M) Between group of external terminals and case
Resistance to Noise	1000Vp-p pulse width 1μs, rise 1ns
Vibration Proof	10 to 500Hz and amplitude 1.5mm or acceleration 98m/s <sup>2</sup> whichever is smaller
Impact Proof	490m/s <sup>2</sup> , (3 times each directions of X, Y and Z respectively)
Enclosure	IP65 (IEC 60529)

Specification (continue)

For Water				
Model	PF2W 704	PF2W 720	PF2W 740	PF2W 711
Fluid to be Measured	Water			
Flow Rate Indication Range	0.35 to 4.5 l/min	1.7 to 17.0 l/min	3.5 to 45 l/min	7 to 110 l/min
Set Flow Rate Range	0.35 to 4.5 l/min	1.7 to 17.0 l/min	3.5 to 45 l/min	7 to 110 l/min
Rated Flow Range	0.5 to 4 l/min	2 to 16 l/min	5 to 40 l/min	10 to 100 l/min
Minimum Set Unit	0.05 l/min	0.1 l/min	0.5 l/min	1 l/min
Flow Rate	0.05 l/pulse	0.1 l/pulse	0.5 l/pulse	1 l/pulse
Conversion Value	(Pulse width: 50msec)	(Pulse width: 50msec)	(Pulse width: 50msec)	(Pulse width: 50msec)
Operating Fluid Temperature	0 to 50°C			
Linearity	±5%F.S. or less			±3%F.S. or less
Repeatability	±3%F.S. or less			±2%F.S. or less
Temperature Characteristic	±5%F.S. or less (0 to 50°C, 25°C standard)			(*)1
Current Consumption (No load)	70mA or less			80mA or less
Mass (Weight) (*2)	460g	520g	700g	1,150g
Piping Specification	3/8	3/8, 1/2	1/2, 3/4	3/4, 1
Material of Wet Part	Attachment: SUS, Packing: NBR, Internal Body: PPS, Sensor: PPS			

For High Temperature fluid

Model	PF2W 704T	PF2W 720T	PF2W 740T
Fluid to be Measured	Water, mixture of 50% water and 50% ethylene glycol		
Flow Rate Indication Range	0.35 to 4.5 l/min	1.7 to 17.0 l/min	3.5 to 45 l/min
Set Flow Rate Range	0.35 to 4.5 l/min	1.7 to 17.0 l/min	3.5 to 45 l/min
Rated Flow Range	0.5 to 4 l/min	2 to 16 l/min	5 to 40 l/min
Minimum Set Unit	0.05 l/min	0.1 l/min	0.5 l/min
Flow Rate	0.05 l/pulse	0.1 l/pulse	0.5 l/pulse
Conversion Value	(Pulse width: 50msec)	(Pulse width: 50msec)	(Pulse width: 50msec)
Operating Fluid Temperature	0 to 90°C (No cavitation)		
Linearity	±5%F.S. or less		
Repeatability	±3%F.S. or less		
Temperature Characteristic	±5%F.S. or less (0 to 90°C, 25°C standard)		
Current Consumption (No load)	70mA or less		
Mass (Weight) (*2)	710g		
Piping Specification	3/8	3/8, 1/2	1/2, 3/4
Material of Wet Part	Attachment: SUS, Packing: FKM, Internal Body: PPS, Sensor: PPS		

Common Specification	
Detecting Method	Karman Vortex Method
Displayed Digits	3digits 7-segment LED
Unit	l/min, gal (US)/min
(*)3 Instantaneous Flow Rate	l, gal (US)
(*)3 Integrated Flow Rate	l, gal (US)
Operating Pressure Range	0 to 1MPa
Withstand Pressure	1.5MPa
Integrated Flow Rate Range	0 to 999999 l
Ambient Temperature Range	Operation: 0 to 50°C, Storage: -25 to 85°C (No condensation or Freezing)
Output Specification (*4)	Switch Output or Integrated Pulse Output
	NPN Open Collector (@ load current 80mA)
	PNP Open Collector (@ load current 80mA), 2 outputs
Operation Indicator Lamp	Lit when Output is ON, (OUT1): Green, (OUT2): Red
Response Time	1sec or less
Hysteresis	Hysteresis Mode: Variable (Settable starting 0), Window Comparator Mode (*5): Fixed (3 digits)
Power Supply Voltage	12 to 24VDC, ripple ±10% or less
Withstand Voltage	1000VAC 1 minute Between group of external terminals and case
Insulation Resistance	50M Ω or more (@ 500VDC M) Between group of external terminals and case
Resistance to Noise	1000Vp-p pulse width 1μs, rise 1ns
Vibration Proof	10 to 500Hz and amplitude 1.5mm or acceleration 98m/s <sup>2</sup> whichever is smaller
Impact Proof	490m/s <sup>2</sup> , (3 times each directions of X, Y and Z respectively)
Enclosure	IP65 (IEC 60529)

\*1: ±3%F.S. or less (15 to 35°C, 25°C standard), ±5%F.S. or less (0 to 50°C, 25°C standard)  
 \*2: Lead wire not included.  
 \*3: With units selection function (Without units selection function, fixed to SI units (l/min or l))  
 \*4: Select either switch output or pulse output of integrated flow rate at the initial setting.  
 \*5: Window Comparator Mode. Hysteresis (H) will be 3 digits. Separate [P\_1] and [P\_2], or [n\_1] and [n\_2], more than 7digits. (In case of the output 2, n\_1,2 becomes n\_3,4 and P\_1,2 becomes P\_3,4)  
 \*6: The flow switch conforms entirely to the CE standard.

Outline with Dimensions (in mm)

PF2A 710 / 750

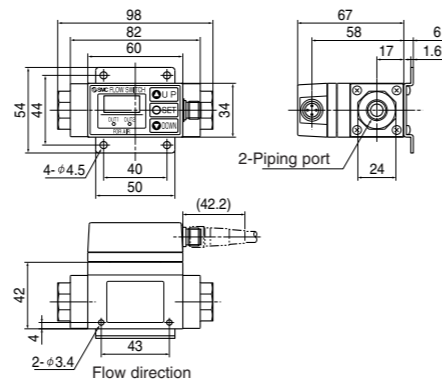

PF2A 711 / 721 / 751

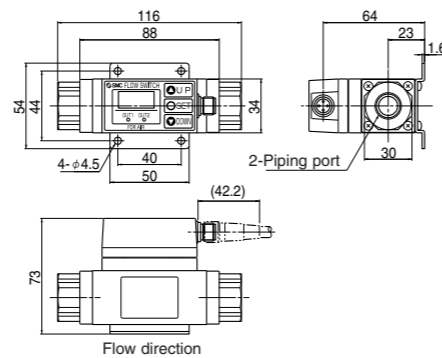

PF2W 704 / 720

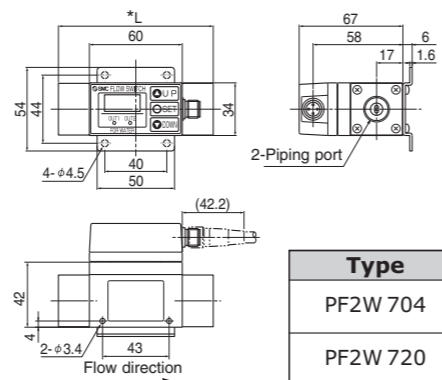

Type	*L
PF2W 704	100mm
PF2W 720	106mm

PF2W 740

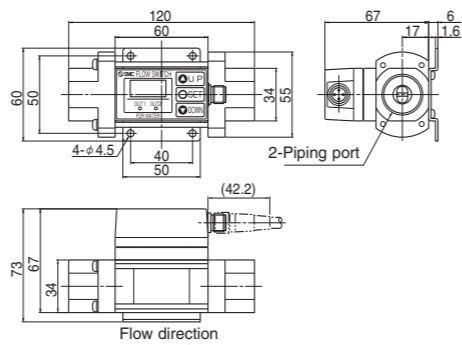

Outline with Dimensions (in mm) (continue)

PF2W 711

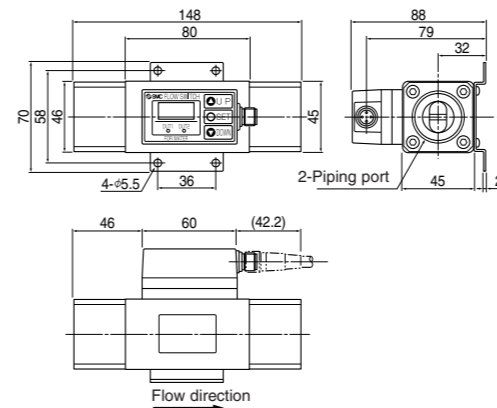

PF2W 704T / 720T / 740T

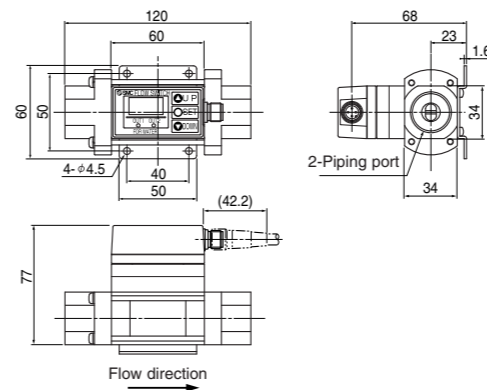

Names and Functions of Individual Parts

Display Part

Output (OUT1) Lamp (Green) : Lit when OUT1 is ON. Flashes when an overcurrent error occurs.  
 Output (OUT2) Lamp (Red) : Lit when OUT2 is ON. Flashes when an overcurrent error occurs.  
 LED Display : Displays the flow rate, set mode status, selected display unit and error codes.  
 ▲ Button (UP) : Selects the mode and increases a set ON/OFF value.  
 ▼ Button (DOWN) : Selects the mode and decreases a set ON/OFF value.  
 SET Button (SET) : Changes the mode and sets a set value.

\* RESET

Pressing the ▲ and ▼ buttons simultaneously will activate the RESET function. Use this function to clear errors when a problem occurs.

Body

Flow switch sensor body  
 The arrow on the side of the body indicates the direction of flow.

Piping port

This port connects with pipeline. Use a pipe fitting to connect with external pipeline.

Accessories

(When no symbol is specified for optional wiring in the type specification.)  
 Lead wire with connector on one end (3m in length)

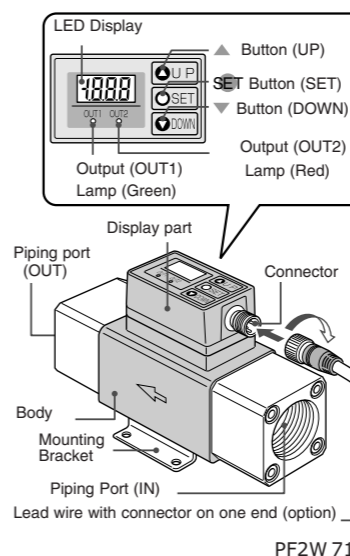

Installation

Before mounting the flow switch, read "Safety Instructions" and "Installation" described in this manual carefully to ensure safe and correct measurement.

Mounting

- Use this flow switch within the specified operating pressure range and operating temperature range.
- Withstand pressure are 1.0MPa for air and 1.5MPa for water.
- Do not install a flow switch at a foothold position.
- Cavitation (bubbles) may be generated depending on the piping design. Refer to the example of a recommended piping system (for water).

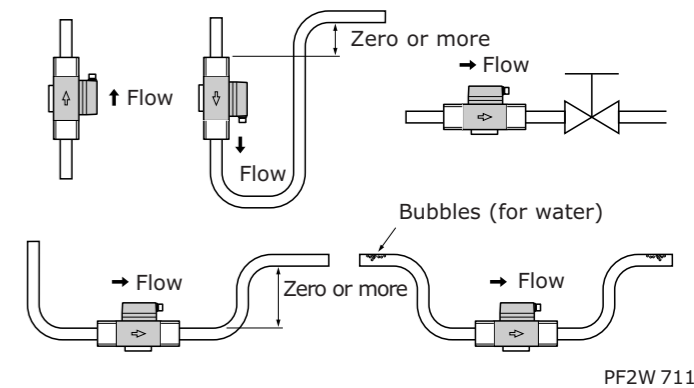

- Install the flow switch so that the flow direction agrees with the arrow direction on the side of the body.
- Provide a straight pipe length of more than eight times the pipe diameter on the primary side (inlet side) of the flow switch.
- To start designing the piping system, check the pressure loss at the operating flow rate using a flow rate characteristic (pressure loss) curve.

- Set the required Display Part position. The Display Part rotates 270P degrees.

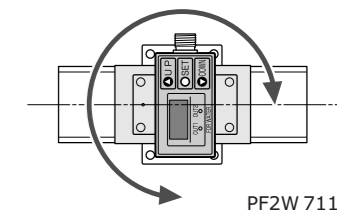

Piping connections

- Use a suitable pipe fitting to connect pipeline with the flow switch.
- Observe the specified tightening torque when connecting pipes. Refer to the following table for the appropriate torque values.

Nominal size of thread	Tightening torque N·m
Rc 1/8	7 to 9
Rc 1/4	12 to 14
Rc 3/8	22 to 24
Rc 1/2	28 to 30
Rc 3/4	28 to 30
Rc 1	36 to 38

- When connecting the pipeline to the flow switch, apply a spanner to the metal part of the flow switch body.
- Make sure that sealing tapes do not enter inside the pipe when connecting pipes.
- Connect pipes securely so that fluid will not leak from loose connections.

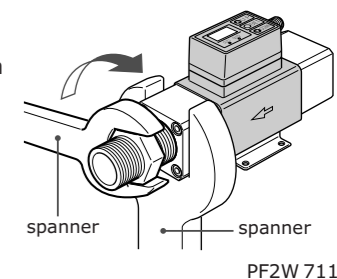

**Installation (continue)**

**Flow rate characteristic (Pressure Loss)**

**PF2A 7\*\***

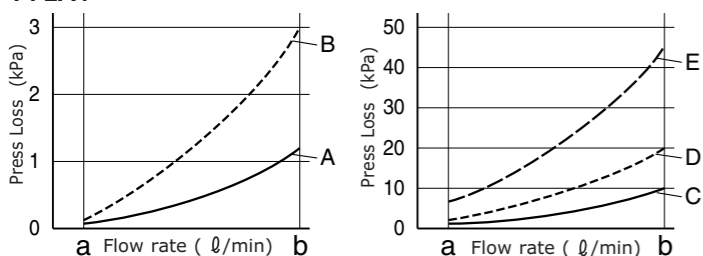

Type	Graph	a (l/min)	b (l/min)
PF2A 710	A	1	10
PF2A 750	B	5	50
PF2A 711	C	10	100
PF2A 721	D	20	200
PF2A 751	E	50	500

**PF2W 7\*\***

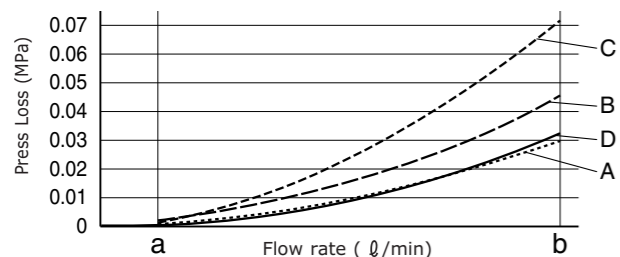

Type	Graph	a (l/min)	b (l/min)
PF2W 704/704T	A	0.5	4
PF2W 720/720T	B	2	16
PF2W 740/740T	C	5	40
PF2W 711	D	10	100

**Internal Circuit and Wiring**

**Output Specification**

When the Lead wire with connector provided by SMC corporation is used the color of wire(Brown, White, Black, Blue) shown on circuit diagram will be applied.

-27

NPN Open Collector Output 2 Outputs  
Max. 30V, 80mA Internal Voltage Drop 1V or less

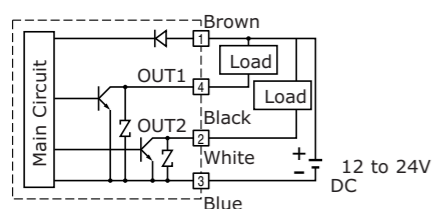

-67

PNP Open Collector Output 2 Outputs  
Max. 80mA Internal Voltage Drop 1.5V or less

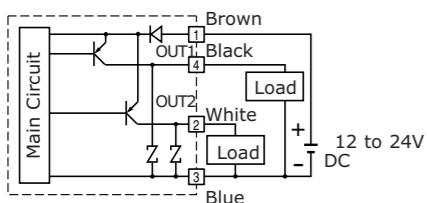

**Internal Circuit and Wiring (continue)**

**How to attach connectors:**

- Turn off power before connecting or disconnecting the connector.
- To insert the connector, push the connector socket of the lead wire to the key part of the switch connector after aligning them to each other and secure the connector with the lock nut.
- To disconnect the connector, unlock the connector lock nut and pull out the connector straight.
- Install the lead wire separately from the route for power cable or high-voltage cable. Otherwise, malfunction may potentially result due to noise.

**Connector pin number**

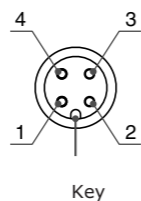

Pin No.	Pin name
1	DC (+)
2	OUT2
3	DC (-)
4	OUT1

**Initialize**

Press and hold the SET button longer than two seconds. Release the SET button when [d\_ ] is displayed.

**1. Display Mode Setting**

Select whether to display instantaneous flow rate or integrated flow rate. To change the Display mode, press the ▲ button and select the desired flow rate to display. Then press the SET button. [d\_1] is for display of an instantaneous flow rate and [d\_2],



**2. Selecting Display Unit**

(When [-M] is not assigned to units specification in model indication)

**Selecting Display Unit**

When [-M] is not assigned to units specification in model indication

Two units each in instantaneous flow rate or integrated flow rate can be selected. Pressing the ▲ or ▼ button in unit setting mode will change the units and a set value will be converted automatically.

Display Part	LED Display	Instantaneous Flow Rate	Integrated Flow Rate
PF2A 7**	U_1	l/min	l
	U_2	CFM×10 <sup>-2</sup> , CFM×10 <sup>-1</sup>	ft <sup>3</sup> × 10 <sup>-1</sup>
PF2W 7**	U_1	l/min	l
	U_2	gal(us)/min	gal(us)

**Selecting Flow rate Display Unit**

(Only for PF2A 7\*\* for Air)

Either normal condition or standard condition (ANR) can be selected.

Normal condition: 0°C/ 101.3kPa  
Standard condition: 20°C/ 101.3kPa/ 65%RH

Press the ▲ button and select the display unit, then press the SET button to set. [nor] means Normal condition and [Anr] means Standard condition.



When normal condition is selected the indicator shown in right illustration will be lit.

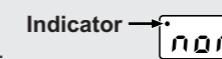

**3. Output Method Setting**

Three output methods are available, namely, instantaneous switch, integrating switch and integrating pulse. The method for output to OUT1 or OUT2 is set as follows.

1)First, the output method for OUT1 is set.

\*Press the ▲ button and select the instantaneous switch, integrating switch or integrating pulse.

\*Press the SET button to set.



[o10] [o11] and [o12] respectively indicate the instantaneous switch, integrating switch and integrating pulse.

2)Select the output method for OUT2 from three output methods by pressing the ▲ button, as in OUT1.

\*Press the SET button to set.



[o20] [o21] and [o22] respectively indicate the instantaneous switch, integrating switch and integrating pulse.

**Initialize (continue)**

**4. Output Mode Setting**

Two output modes are available, namely, the Reverse Output mode and Non-Reverse Output mode. An output mode for OUT1 and OUT2 is set.

1)First, the output method for OUT1 is set.

\* Press the ▲ button and select the Reverse Output mode or Non-Reverse Output mode.

\* Press the SET button to set.

[1\_n] and [1\_P] respectively indicate the Reverse Output mode and Non-Reverse Output mode.



2)Select the output method for OUT2 from the Reverse Output mode and Non-Reverse Output mode by pressing the ▲ button, as in OUT1.

\* Press the SET button to set.

[2\_n] and [2\_P] respectively indicate the Reverse Output mode and Non-Reverse Output mode.



**Setting**

**Setting Procedures**

Check installation condition and wiring and set as follows

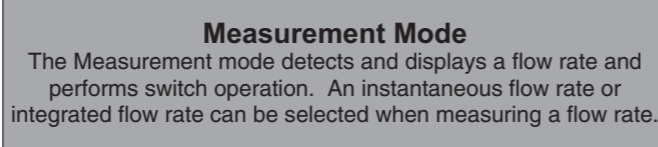
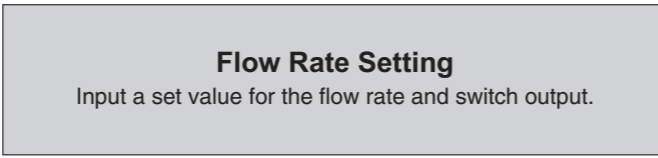
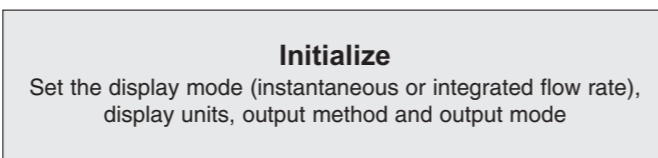
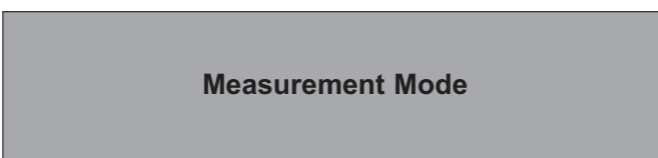

**Display of Integrated Flow Rate**

•Press the ▼ button and the SET button both simultaneously. Integration starts when [-] flashes.

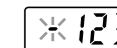

•The lower three digits of an integrated value are always displayed. Press the ▼ button when wishing to check the upper three digits.

•Pressing the ▲ button enables the display of instantaneous flow rate even during integration.

•To stop integration, press the ▼ button and the SET button simultaneously.

The display will keep the present integrated value.



To clear display of an integrated value, press both the ▲ and ▼ buttons simultaneously for longer than two seconds.

To further continue integration from the saved value, press the ▼ button and the SET button simultaneously.

## Instantaneous Flow Rate Setting Mode

### Manual

Manually set the required actuation value when the instantaneous value switch has been selected in initialization. The output method is also set manually in accordance with the set value. Set the output method while referring to the output method described later in this manual.

- Press and hold the **SET** button and release when [F-1] is displayed. 
- Press the **SET** button to input a set value in [n\_1] (P\_1 in the Non-Reverse Output mode) for OUT1. 

When the Reverse Output mode is selected in initialization, [n\_1] and the set value will be displayed alternately. (When the Non-Reverse Output mode is selected in initialization, [P\_1] and the set value will be displayed alternately.)
- Press the **▲** or **▼** buttons to select a desired set value. Press the **▲** button to increase the set value or the **▼** button to decrease the set value.
- Press the **SET** button to set the value and to move to the setting mode for [n\_2] (P\_2 in the Non-Reverse Output mode). 



When the Reverse Output mode is selected in initialization, [n\_2] and the set value will be displayed alternately. (When the Non-Reverse Output mode is selected in initialization, [P\_2] and the set value will be displayed alternately.)
- Press the **▲** or **▼** buttons to select a desired set value. Press the **▲** button to increase the set value or the **▼** button to decrease the set value.

- Press the **SET** button to set the value and to move to the setting mode for OUT2. Set the required values as in OUT1. When the Reverse Output mode is selected for the OUT2 setting in initialization, [n\_3] or [n\_4] and the set value will be displayed alternately. When the Non-Reverse Output mode is selected in initialization, [P\_3] or [P\_4] and the set value will be displayed alternately.
- Completing settings for [n\_1] to [n\_4] ([P\_1] to [P\_4] in the Non-Reverse Output mode) will finish flow rate setting and the mode will return to the Measurement mode.

## Instantaneous Flow Rate Setting Mode (continue)

### Auto Presetting

The flow rate flowing through the flow switch will be set as a reference value and a Hysteresis (H) will be set automatically at a value 3 digits lower when setting auto preset input. The output method for setting by auto presetting is only hysteresis mode.

- Press and hold the **SET** button and release when [F\_1] is displayed. 
- Press the **▲** button and change [F\_1] in the display to [F\_2]. 
- Press the **SET** button and set the auto preset state of OUT1. 

The display will change to show [AP1]. (When OUT1 setting is not needed, press the **▲** and **▼** button simultaneously.)
- Prepare the equipment to set the flow rate of OUT1 and flow fluid through the flow switch at the required flow rate.
- Pressing the **SET** button will automatically read the flow rate. A value 3 digits lower will be set automatically as a Hysteresis (H). The display will show [A1L] and the set value alternately.
- Press the **SET** button and set auto preset state of OUT2. 

The display will change to show [AP2]. (When OUT2 setting is not needed, press the **▲** and **▼** buttons simultaneously.)
- Prepare the equipment to set the flow rate of OUT2 and flow fluid through the flow switch at the required flow rate.
- Pressing the **SET** button will automatically read the flow rate. A value 3 digits lower will be set automatically as a Hysteresis (H). The display will show [A2L] and the set value alternately.
- Press the **SET** button to finish the Auto Presetting mode and the mode will return to the Measurement mode.

## Integrated Flow Rate Setting Mode

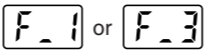
- The switch is set to an integrated flow rate. 
- Integrated flow rate is displayed by switching between lower three digits and upper three digits. Settings are also made by dividing into lower three digits and upper three digits.

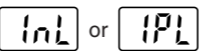
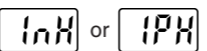
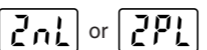
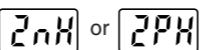
- Press and hold the **SET** button and release when [F\_1] or [F\_3] is displayed. Proceed to Step 3. if [F\_3] is displayed. ([F\_1] will be displayed when the instantaneous switch is selected for any switch output in initialization. In other cases, [F\_3] will be displayed.)
- When [F\_1] is displayed, push the **▲** button until the display shows [F\_3]. The subsequent setting operation will be the same as that when [F\_3] is displayed.
- Set as follows if [F\_3] is displayed.
  - Press the **SET** button to display the lower three digits of the integrated flow rate of OUT1. 
  - Press the **▲** or **▼** buttons and adjust to the desired set value.
  - Press the **SET** button to set. The upper three digits of OUT1 will be displayed. 
  - Press the **▲** or **▼** buttons and adjust to the desired set value.
  - Press the **SET** button to set. The lower three digits of OUT2 will be displayed. 
  - Press the **▲** or **▼** buttons and adjust to the desired set value.
  - Press the **SET** button to set. The upper three digits of OUT2 will be displayed.
  - Press the **▲** or **▼** buttons and adjust to the desired set value. 
  - Press the **SET** button to finish setting the integrated flow rate and the mode will return to the Measurement mode.

## Output Selection

### Instantaneous Switch Output Method

- Four output methods can be selected by selecting an output mode and by combining large and small set values of OUT1 and OUT2. One of these four output methods can be selected for each output.
- OUT1 and OUT2 can be set independently.
  - The minimum flow rate conversion set unit will be 1 digit. Refer to the specification for the set flow rate units.
  - When setting in the Window Comparator mode, the Hysteresis will be set automatically. Hysteresis in this case will be 3 digits fixed.
  - In the Window Comparator mode, between [P\_1] and [P\_2] or between [n\_1] and [n\_2], the span must be more than 7 digits.
  - The following is given using OUT1 as an example. The descriptions for OUT2 are the same as those for OUT1, under the conditions that [n\_1] and [n\_2] should be replaced by [n\_3] and [n\_4], or [P\_1] and [P\_2] should be replaced by [P\_3] and [P\_4].

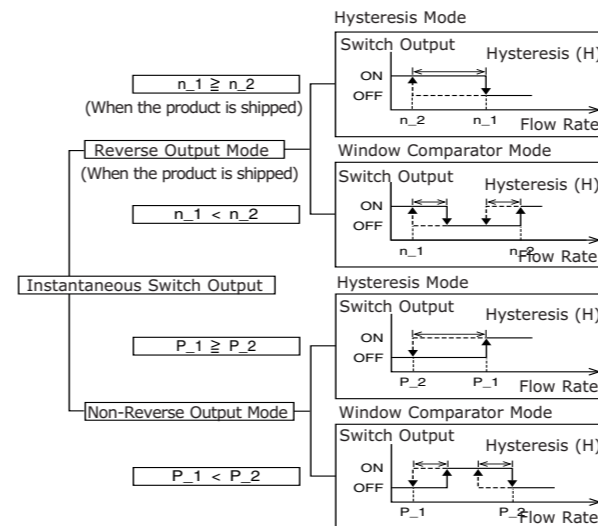

### Integrated Switch Output

- Two output methods can be selected by selecting an output mode. One of these two output methods can be selected for each output.
- OUT1 and OUT2 can be set independently.
- The following is given using OUT1 as an example. The descriptions for OUT2 are the same as those for OUT1, under the conditions that 1nL and 1nH should be replaced by 2nL and 2nH and 1PL and 1PH should be replaced by 2PL and 2PH.

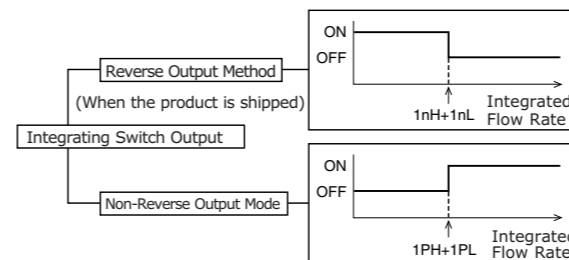

### Integrated Pulse Output

- Pulse output for integrated flow rate measurement.

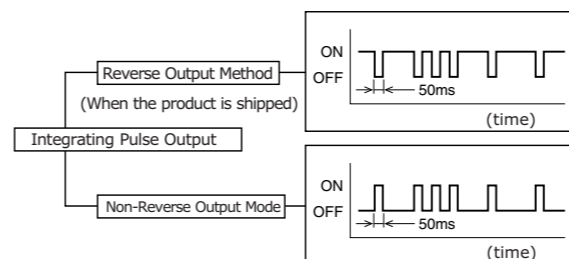

## Other Functions

### Key Lock Function

This function prevents errors such as changing a set value by mistake.

#### Lock

- Press and hold the **SET** button longer than three seconds. 

The display will change to show [F\_1] → [d\_ ] → [unL]. Release the button when [unL] is displayed.
- Press the **▲** button to set the display to [Loc]
- Press the **SET** button to return to the Measurement mode.

#### Unlock

- Press and hold the **SET** button longer than three seconds. 

Release the button when [Loc] is displayed.
- Press the **▲** button to change the display to [unL]
- Press the **SET** button to return to the Measurement mode.

### Error Display and Troubleshooting

In case an error occurs, take the following actions:

LED Display	Error Nature	Troubleshooting
Er1	A current exceeding 80mA is flowing to OUT1.	Turn the power off. Check the load and wiring of OUT1.
Er2	A current exceeding 80mA is flowing to OUT2.	Turn the power off. Check the load and wiring of OUT2.
Er4	Set data has been changed due to an unknown reason.	Reset and return the settings to those that were set when the equipment was delivered to you. If the settings cannot be reset, then the flow switch should be returned to SMC.
- - -	The fluid is flowing at a flow rate higher than the rated value.	Reduce the flow below the rated value. The Error display will automatically reset when the flow is reduced to below the rated value.

To reset display of Error 1, 2 or 4, press the **▲** and **▼** buttons simultaneously.

## Contact

AUSTRIA	(43) 2262 62280	NETHERLANDS	(31) 20 531 8888
BELGIUM	(32) 3 355 1464	NORWAY	(47) 67 12 90 20
CZECH REP.	(420) 541 424 611	POLAND	(48) 22 211 9600
DENMARK	(45) 7025 2900	PORTUGAL	(351) 21 471 1880
FINLAND	(358) 207 513513	SLOVAKIA	(421) 2 444 56725
FRANCE	(33) 1 6476 1000	SLOVENIA	(386) 73 885 412
GERMANY	(49) 6103 4020	SPAIN	(34) 945 184 100
GREECE	(30) 210 271 7265	SWEDEN	(46) 8 603 1200
HUNGARY	(36) 23 511 390	SWITZERLAND	(41) 52 396 3131
IRELAND	(353) 1 403 9000	UNITED KINGDOM	(44) 1908 563888
ITALY	(39) 02 92711		

## SMC Corporation

URL <http://www.smcworld.com> (Global) <http://www.smceu.com> (Europe)

Specifications are subject to change without prior notice from the manufacturer. © SMC Corporation All Rights Reserved.