



Installation and Maintenance Manual

Electro Pneumatic Positioner - Rotary type

with 4-20mA output

IP8100-0#1-#J-X83 / IP8100-0#1-#X84



EMC Directive 89/336/EEC
 EN 61000-6-2:2001: Electromagnetic Compatibility (EMC) - Immunity
 EN 61000-6-3:2001: Electromagnetic Compatibility (EMC) - Emission
 EN 55011:1998: Limits and methods of measurement of radio disturbance characteristics of industrial, scientific and medical radio-frequency equipment and light-industrial environments

1 Safety Instructions

- This manual contains essential information for the protection of users and others from possible injury and/or equipment damage.
- Read this manual before using the product, to ensure correct handling, and read the manuals of related apparatus before use.
- Keep this manual in a safe place for future reference.
- These instructions indicate the level of potential hazard by label of "DANGER", "WARNING" or "CAUTION", followed by important safety information which must be carefully followed.
- To ensure safety ISO4414: Pneumatic Fluid power and JIS B 8370: Pneumatic System principles must be observed, along with other relevant safety practices.

⚠ DANGER	In extreme conditions, there is a possibility of serious injury or loss of life.
⚠ WARNING	If instructions are not followed there is a possibility of serious injury or loss of life.
⚠ CAUTION	If instructions are not followed there is a possibility of injury or equipment damage.

⚠ WARNING

- The compatibility of pneumatic equipment is the responsibility of the person who designs the pneumatic system or decides its specifications.**

Since the products specified here can be used in various operating conditions, their compatibility with the specific pneumatic system must be based on specifications or after analysis and/or tests to meet specific requirements.

- Only trained personnel should operate pneumatically operated machinery and equipment.**
- Compressed air can be dangerous if an operator is unfamiliar with it. Assembly, handling or repair of pneumatic systems should be performed by trained and experienced personnel.
- Do not service machinery/equipment or attempt to remove components until safety is confirmed.**
 - Inspection and maintenance of machinery/equipment should only be performed after confirmation of safe locked-out control positions.
 - When equipment is to be removed, confirm the safety process as mentioned above. Switch off air and electrical supplies and exhaust all residual compressed air in the system.
 - Before machinery/equipment is re-started, ensure all safety measures to prevent sudden movement of cylinders etc. (Supply air into the system gradually to create back pressure, i.e. incorporate a soft-start valve).
- Do not use this product outside of the specifications. Contact SMC if it is to be used in any of the following conditions:**
 - Conditions and environments beyond the given specifications, or if the product is to be used outdoors.
 - Installations in conjunction with atomic energy, railway, air navigation, vehicles, medical equipment, food and beverage, recreation equipment, emergency stop circuits, press applications, or safety equipment.
 - An application which has the possibility of having negative effects on people, property, or animals, requiring special safety analysis.

⚠ CAUTION

- Ensure that the air supply system is filtered to 5 microns.

2 Specifications

Protect the unit from impact and dropping during transfer and when mounted. This may cause failure of the unit.

- Do not use the unit in places with high humidity and temperature. This may cause malfunction.
- Do not use this product outside of the range of its specifications, as this can cause failure.

Item	IP8100	
	Single action	Double action
Type	Rotary type cam	
Input current	4~20 mADC (Standard) *1	
Input resistance	235±15Ω (4 ~ 20 mADC)	
Supply Air Pressure	0.14~0.7 MPa	
Standard stroke	60° to 100° *2	
Sensitivity	Within 0.5% F.S.	
Linearity	Within ±2% F.S.	
Hysteresis	Within 1% F.S.	
Repeatability	Within ±0.5% F.S.	
Thermal coefficient	Within 0.1% F.S/°C	
Output flow rate	200 l/min (ANR) or more (SUP=0.4 MPa) *3	
Air consumption	Within 11 l/min (ANR) (SUP=0.4 MPa)	
Ambient / Fluid temperature	-20°C to +80°C	

Air connection Port	NPT1/4 (Female) : IP8100-0#1-#J-X83 Rc1/4 (Female) : IP8100-0#1-#X84
Electrical wiring connection Port	G1/2 (Female)
Output Signal	4-20 mADC
Power Supply	12-35 V (for output current detection)
Resistance Load	Power Supply-12 V 20 mADC
Output characteristic	±2% F.S.
Hysteresis	1% F.S.
Temperature coefficient	0.06% F.S/°C
Material	Body - Aluminium diecast
Weight	Approx 2.6 kg
Protection Classification	JISF8007, IP65 (IEC 60529)

- * 1 : 1/2 split range is possible using the standard type (by adjusting the span).
- * 2 : The stroke is adjustable for 0 to 60° and 0 to 100°.
- * 3 : Standard air (JIS B0120): temp.20 °C, absolute press.760 mm Hg, ratio humidity 65%.

2 Specifications (continued)

2.1 How to Order

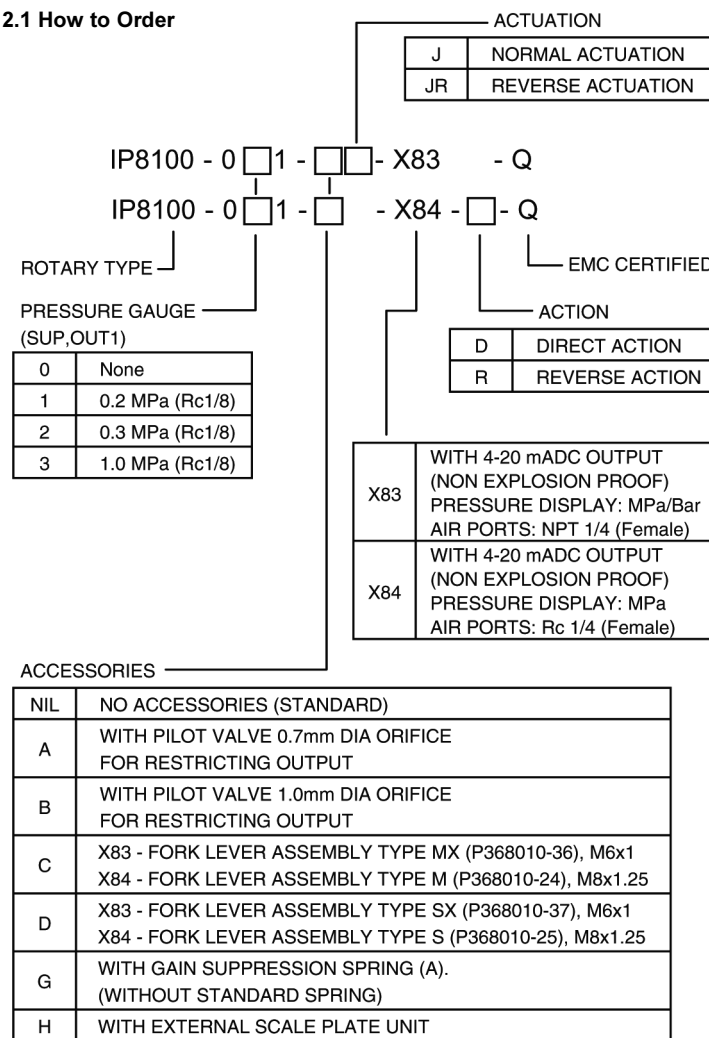

NOTE: WHEN MORE THAN 2 ACCESSORIES ARE REQUIRED, SPECIFY IN ALPHABETICAL ORDER.

3 Installation

3.1 Installation

⚠ WARNING

- Do not install the product unless the safety instructions have been read and understood.
- Since the zero point varies depending on the mounting position, the zero point should be adjusted after installation.
- Avoid hitting the product with metal objects!
- Avoid using the product in non-explosive environments which can become explosive due to air leakage!

3.2 Environment

⚠ WARNING

- Do not use in an environment where the product is directly exposed to corrosive gases, chemicals, salt water, water or steam.
- The product should not be exposed to prolonged sunlight. Use a protective cover.
- Do not mount the product in a location where it is subject to strong vibrations and/or shock.
- Do not mount the product in a location exposed to radiant heat.
- Allow sufficient space for maintenance and adjustment around the product when mounted.

3 Installation (continued)

3.3 Piping

⚠ CAUTION

- Before piping make sure to clean away chips, cutting oil, dust etc.
- When installing piping or fittings, ensure sealant material does not enter inside the port.
- When using seal tape, leave 1.5 to 2 threads exposed on the end of the pipe/fitting.
- Tighten fittings according to appropriate tightening torque.

3.4 Lubrication

⚠ CAUTION

- The Positioner has a fixed orifice and nozzle, which contain fine paths. Use filtered, dehydrated air and avoid the use of lubricators as this may cause malfunction of the Positioner.
- Ensure that the air supply system is filtered to 5 microns.

3.5 Handling

⚠ CAUTION

- Avoid impact to the body and torque motor of the positioner, and applying excessive force to the armature, because this may lead to failure. Handle with care during transportation and operation.
- If the Positioner is left at the operation site for a long time before installation, cover it to prevent rain water from entering the positioner. If the atmosphere is of high temperature or humidity, take measures to avoid condensation inside the positioner. Condensation control measures must be taken thoroughly during export shipment.
- Avoid setting the positioner near magnetic fields because the characteristics will be affected.

4 Mounting

4.1 Mounting IP8100 to Actuator

The IP8100 positioner is compatible with IP6100 and IP610 mounting pitch. If you are using the IP6100 or IP610 already, the bracket for these positioners can be used to mount the IP8100 to the actuator.

If changing from IP6100 to IP8100 and selecting accessory H (with external scale plate unit), the fork lever type fitting will need to be adjusted to a lower position.

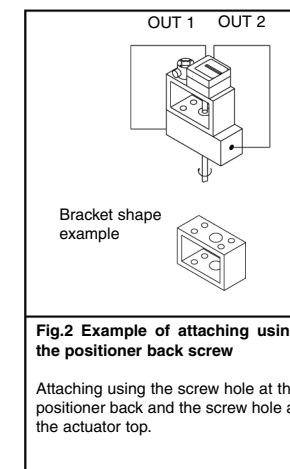
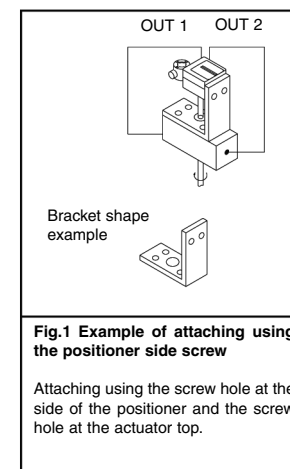

4.2 Connection with feedback shaft

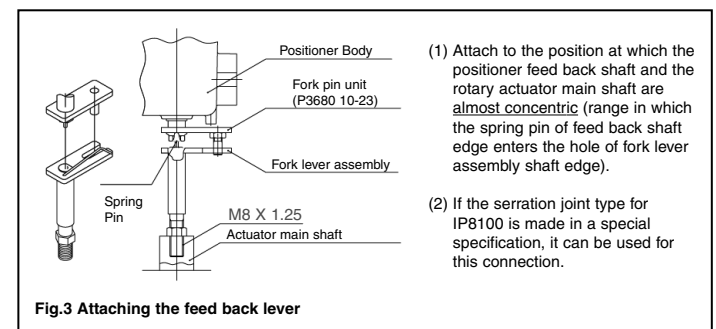

4 Mounting (continued)

4.3 Cam attaching procedure

CAUTION

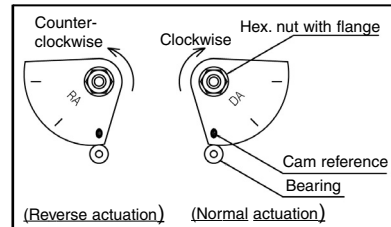

Fig.4 Example of cam attaching

- Use the DA face of the cam to turn the actuator main shaft clockwise (viewed from the positioner front cover side) at the time of input signal increase. Use the RA face to turn it counter-clockwise (reverse actuation). Correctly attach the cam to the flange part of feed back shaft.
- Attach the cam in the procedure of loosening the hexagonal nut with flange first, setting the used actuator to the starting position and then setting the cam reference line and the bearing contact point of span adjusting arm unit to the matching position.
- Do not apply the supply pressure when attaching the cam as otherwise it is very dangerous.
- When the positioner is shipped from the factory, the cam is tentatively tightened to the shaft. Be sure to firmly lock the cam to the lock nut [tightening torque 2.0 ~ 2.5 Nm.

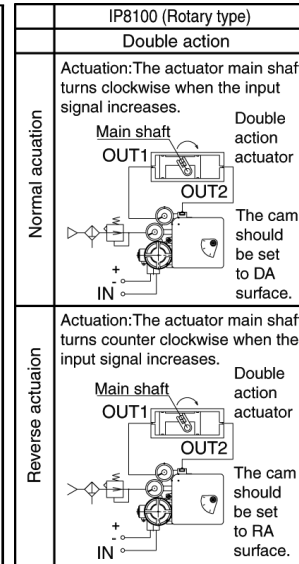

FIG.5 Direct / Reverse actuation

5 Adjustment

CAUTION

Check the following prior to starting the adjustment

- Check that the pipeline is correctly connected with the pressure supply port and OUT1 and OUT2 ports.
- Check that the actuator and positioner are sturdily connected.
- Check for locking of the auto / manual changeover screw of the pilot valve (fully tightened in the clockwise direction).

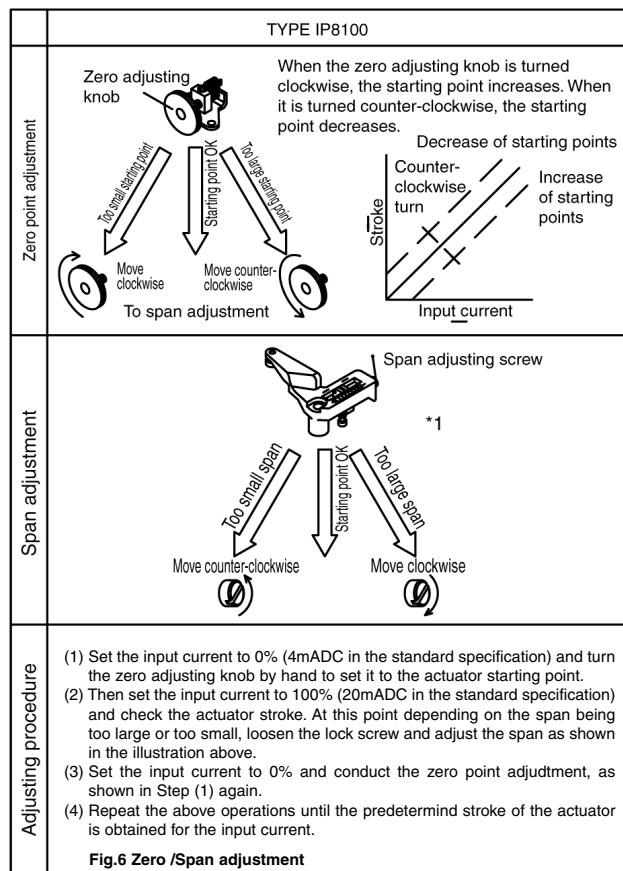

Fig.6 Zero /Span adjustment

5 Adjustment (continued)

- Check for correct use of the cam face (normal or reverse) and that the flange nut is firmly locked (refer to Fig.5).
- Check that the wires are connected correctly to the (+), (-) and Ground terminals.

CAUTION

- For this positioner, span and zero point adjustment of each actuator is necessary. Adjustment should be carried out based on each actuator size.
- Keep in mind that the span and zero point adjustment interfere with each other.
- Characteristics change due to change of mounting position, ambient temperature and supply pressure.
- If the positioner takes a long time to operate after initial adjustment, check and adjust the product again.
- Sensitive adjustment is effective for only double acting actuators.
- Manual change function is effective for single acting actuators which are controlled by using OUT1

5.1 Electrical wiring

This product has a potentiometer and p.c.board built into it. This is for confirming the actuator's opening by a 4-20 mADC output signal produced by supplying initial power to the pcb. This supply power can be set freely between 12-35 VDC.

According to the operating direction of the actuator or feed back lever, the clockwise potentiometer direction gives regular operation, and the counter-clockwise direction gives opposite operation.

5.1.1 Wiring of Input signal & Power source

- Connect the input signal wires (for positioner control) to 1 (+) and 2 (-) of the terminal board in the terminal box.
- Connect the power source wires (for powering the output current detection circuit) to 3 (+) and 4 (-) of the terminal board.
- Connect an ammeter in series between (+) side and 3 (+) of terminal board, or (-) side and 4 (-) terminals.

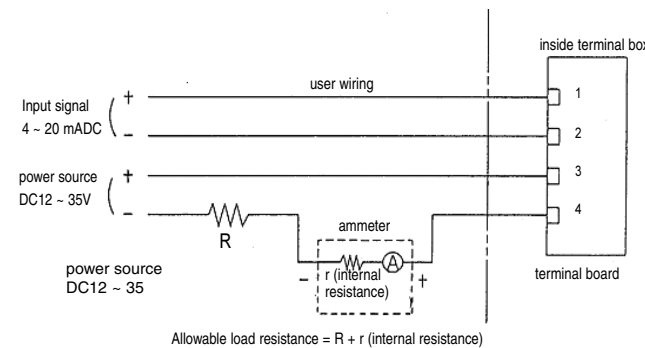

NOTE ! Allowable load resistance depends on supply voltage

- The allowable load resistance is determined using the formula below.
Allowable load resistance = (Supply voltage-12V) / 20 mADC-(1)

Normal output current is not obtained if the load resistance value exceeds the results of the formula. Please confirm internal resistance when selecting an ammeter.

5.2 Zero / Span adjustment (Output)

Zero point / Span adjustment of the output current of the positioner (with potentiometer) should be carried out after initial zero / span adjustments in Fig.6.

This product requires zero / span adjustment of the output current according to the actuators rotating angle (rotary type).

Please follow the procedure below:

- Set the actuator's output opening or stroke to 0% after adjusting the zero / span.

5 Adjustment (continued)

- Adjust the zero / span with the variable resistors on the p.c.board (refer to Fig.8).
- Adjust the zero point and span alternately and repeatedly as they interact with each other. Since this variable resistor can be wound endlessly, do not overwind, otherwise internal equipment might be damaged. Adjust while monitoring the output signal.

5.3 Change of Operating Direction (IP8100 Rotary)

- The Output signal is configured to increase in normal operation (clockwise) when shipped from the factory.
- To apply the positioner in reverse operation (counter-clockwise), specify the accessory classification JR when ordering. Alternatively, to change the operation of the delivered product, re-arrange the cam to the opposite side and switch the terminals A and C (refer to Fig.7), to reverse the direction of the output signal.
- Loosen the potentiometer set screw while applying power and ensuring an output current, then rotate the potentiometer 10-20° away from the dead band (see Fig.8) to decide the start point. Settle the potentiometer with the set screws again.

CAUTION

(Setting Potentiometer)

- The Output signal does not operate at the deadband of the potentiometer.
- If the start point is set at 4 mADC, at the border line of the resistance range and the deadband, malfunction may occur.
- If the Output current is 0 mADC during opening, the potentiometer may be set across the border between the resistance range and the deadband. Follow the steps above noting the potentiometer rotation direction.
- When the rotary positioner is used in reverse action, adjust the potentiometer fixing position to avoid clashing of the cam and potentiometer lead wire.

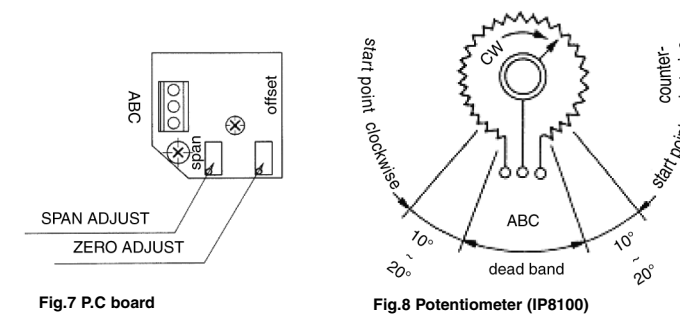

Fig.7 P.C board

Fig.8 Potentiometer (IP8100)

6 Maintenance

CAUTION

- After installation, repair and disassembly, connect compressed air and perform a proper function test and leak test. If bleed noise is louder than the initial state, or operation is abnormal, stop operation and check if the installation is correct.

CAUTION

- Check if supply air is clean or not. Inspect compressed air cleaning system periodically so that dust, oil and humidity do not enter the unit. This can cause malfunction or failure of the unit.
- If handled improperly, compressed air can be dangerous. Maintenance and replacement of unit parts should only be performed by trained and experienced personnel for instrumentation equipment, as well as following the product specifications.
- Check the positioner once a year. When an excessively worn diaphragm, O-ring or other seals of any unit that has been damaged is found, replace with new ones. Treatment at an early stage is especially important if the positioner is used in a place of severe environment, such as coastal areas.
- Before removing the positioner for maintenance, or replacing unit parts after installation, ensure the supply pressure is shut off and all residual air pressure is released from the piping.
- When the fixed orifice is clogged with carbon particles or other material, remove the pilot valve Auto/Manual change over screw (built in fixed aperture) and clean it by carefully inserting a 0.3mm diameter wire into the aperture.
- When disassembling the pilot valve, coat the O-ring of the sliding section with grease. (Use TORAY SILICONE SH45 grease).
- Check for air leaks from the compressed air piping. Air leaks could reduce the performance characteristics of the positioner. Air is normally discharged from a bleed port, but this is necessary air consumption based on the construction of the positioner, and is not abnormal if the air consumption is within the specified range.

7 Contacts

AUSTRIA	(43) 2262-62 280	ITALY	(39) 02-92711
BELGIUM	(32) 3-355 1464	NETHERLANDS	(31) 20-531 8888
CZECH REP.	(420) 5-414 24611	NORWAY	(47) 67 12 90 20
DENMARK	(45) 70 25 29 00	POLAND	(48) 22-548 50 85
FINLAND	(358) 207-513 513	PORTUGAL	(351) 2 610 89 22
FRANCE	(33) 1-64 76 1000	SPAIN	(34) 945-18 4100
GERMANY	(49) 6103 4020	SWEDEN	(46) 8-603 0700
GREECE	30) 1- 342 6076	SWITZERLAND	(41) 52-396 3131
HUNGARY	(36) 1-371 1343	TURKEY	(90) 212 221 1512
IRELAND	(353) 1-403 9000	UNITED KINGDOM	(44) 1908-56 3888

SMC Corporation www.smcworld.com (Global) www.smceu.com (Europe)

Specifications are subject to change without prior notice from the manufacturer. The descriptions of products in this document may be used by other companies.

© SMC Corporation All Rights Reserved.

*1 When the span adjusting screw is turned clockwise with a screwdriver, the span decreases. When it is turned counter-clockwise, the span increases.