



Installation and Maintenance Manual

IP6000/IP6100 0#0 - # - X14

Electropneumatic Positioner

CE Ex IIC T6 -20°C ≤ Ta ≤ 60°C
T5 -20°C ≤ Ta ≤ 80°C

ATEX marking description

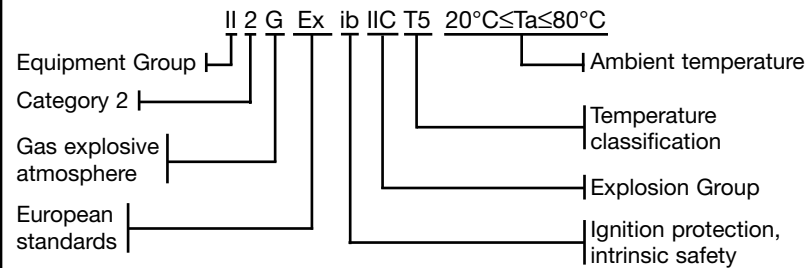

1 SAFETY RECOMMENDATION

1.1 General recommendation

These safety instructions are intended to prevent a hazardous situation and/or equipment damage. These instructions indicate the level of potential hazard by label of "Caution", "Warning" or "Danger". To ensure safety, be sure to observe ISO4414 (Note1), JIS B 8370 (Note2) and other safety practices.

Note 1: ISO 4414: Pneumatic fluid power - Recommendations for the application of equipment to transmission and control systems. Note 2: JIS B 8370: Pneumatic system axiom.

WARNING

- The compatibility of pneumatic equipment is the responsibility of the person who designs the pneumatic system or decides its specifications.



CAUTION: Operator error could result in injury or equipment damage.



WARNING: Operator error could result in injury or loss of life.



DANGER: In extreme conditions, there is possible result of serious injury or loss of life.

Since the products specified here are used in various operating conditions, their compatibility for the specific pneumatic system must be based on specifications or after analysis and/or tests to meet your specific requirements.

- Only trained personnel should operate pneumatically operated machinery and equipment.

Compressed air can be dangerous if an operator is unfamiliar with it. Assembly, handling or repair of pneumatic systems should be performed by trained and experienced operators.

- Do not service machinery/equipment or attempt to remove component until safety is confirmed.

- Inspection and maintenance of machinery/equipment should only be performed after confirmation of safe locked-out control positions.
- When equipment is to be removed, confirm the safety process as mentioned above. Switch off air and electrical supplies and exhaust all residual compressed air in the system.
- Before machinery/equipment is re-started, ensure all safety measures to prevent sudden movement of cylinders etc. (Supply air into the system gradually to create backpressure, i.e. incorporate a soft-start valve).

- Contact SMC if the product is to be used in any of the following conditions:

- Conditions and environments beyond the given specifications, or if product is used outdoors.
- Installations in conjunction with atomic energy, railway, air navigation, vehicles, medical equipment, food and beverage, recreation equipment, emergency stop circuits, press applications, or safety equipment.
- Applications, which have the possibility of having negative effects on people, properties or animals, requiring special safety analysis.

1.2 Conformity to standard

This product is certified to and complies with the following standards:

- ATEX Directive 94/9/EC
- EN60079-0:2006 Electrical apparatus for potentially explosive atmospheres. General requirements
- EN50020:2002 Electrical apparatus for potentially explosive atmospheres. Intrinsic safety 'i'
- EN13463-1:2001 Non-Electrical equipment for potentially explosive atmospheres. Basic method and requirements

2 SPECIFICATIONS

Protect the unit from impact and dropping during transfer and when mounted. It may cause failure of the unit.

- Do not use the unit in places with high humidity & temperature. It may cause malfunctions.
- Do not use this positioner outside of the range of its specifications as this can cause failure.

Item	Type	IP6000		IP6100	
		Lever type lever		Rotary type cam	
		Single action	Double action	Single action	Double action
Input current		4~20mADC (Standard)*1			
Input resistance		235 ± 15Ω (4~20mADC)			
Supply air pressure		0.14~0.7Mpa			
Standard stroke		10 ~ 85mm (External lever allowable runout angle 10° ~ 30°)		60° ~ 100°*2	
Sensitivity		Within 0.1%F S		Within 0.5%F S	
Linearity		Within ±1%F S		Within ±2%F S	
Hysteresis		Within 0.75%F S		Within 1%F S	
Repeatability		Within ±0.5%F S			
Thermal coefficient		Within 0.1%F S/°C			
Output flow rate		80 l/min (ANR) or more (SUP=0.14MPa)*3			
Air consumption		Within 5 l/min (ANR) (Sup=0.14MPa)			
Ambient and using fluid temperature		-20°C ~80°C (T5)			
		-20°C ~60°C (T6)			
Explosion protected Construction		Intrinsic safety type of explosion protection (CE 0344 Ex IIC T5/T6) Approval No. KEMA No.03 ATEX1119			
Air connection port		1/4NPT female screw			
Electric wiring connection port		M20 x 1.5			
Material		Aluminum diecast for the body			
Mass		Approx. 2.4kg			
Classification of degree of protection		JISF8007 IP55 (conform to IEC pub.529)			
Parameters (Current circuit)		Ui ≤ 28V, Ii ≤ 125mA, Pi ≤ 1.2W, Ci ≤ OnF, Li ≤ OmH			

*1 : 1/2 split range is possible with the standard type (by adjusting the span)

*2 : The stroke is adjustable in 0~60° and 0~100°.

*3 : Standard air (JIS B0120): temp.20°C, absolute press. 760mmHg, ratio humidity 65%.

2.1 How to Order

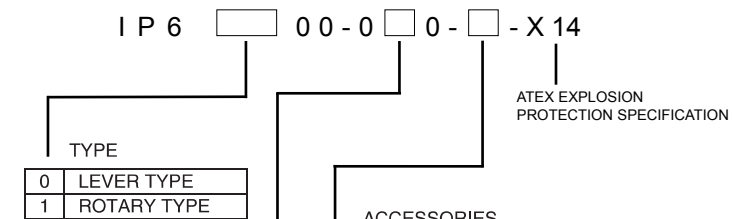

ACCESSORIES	
NIL	NO ACCESSORIES (WITH STANDARD LEVER)
A	WITH PILOT VALVE ADDED DIA. 0.7mm ORIFICE FOR RESTRICTING OUTPUT.
B	WITH PILOT VALVE ADDED DIA. 1.0mm ORIFICE FOR RESTRICTING OUTPUT.
C	FORK LEVER ASSEMBLY, TYPE MX (P368010-36)
D	FORK LEVER ASSEMBLY, TYPE SX (P368010-37)
E	WITH LEVER FEEDBACK UNIT FOR STROKE 35 ~ 100mm, (WITHOUT STANDARD LEVER)
F	WITH LEVER FEEDBACK UNIT FOR STROKE 50 ~ 140mm, (WITHOUT STANDARD LEVER)
G	WITH GAIN SUPPRESSION SPRING (A). (WITHOUT STANDARD GAIN SUPPRESSION SPRING)

NOTE : WHEN MORE THAN 2 ACCESSORIES ARE REQUIRED, THE SYMBOL SHOULD BE STATED IN ALPHABETICAL ORDER.

3 INSTALLATION

WARNING

- Do not install unless the safety instructions have been read and understood.
- Since zero-point varies depending on the mounting position, the zero point should be adjusted after installation.
- Avoid hitting the product with metallic objects!
- Avoid using this product in non-explosive environments which can become explosive due to air leakage!
- When using this product in hazardous areas, ensure that the operational speed of the moving parts is less than 1m/s, and that the actuator is not hunting!

3.1 Environment

WARNING

- Do not use in an environment where the product is directly exposed to corrosive gases, chemicals, salt water, water or steam.
- The product should not be exposed to prolonged sunlight that can generate a surface temperature higher than the value given for the temperature classification. Use a protective cover.
- Do not mount the product in a location where it will be subject to strong vibrations and/or shock.
- Do not mount the product in a location where it is exposed to radiant heat.
- Allow sufficient space for maintenance and adjustment around the product when mounted.

3.2 Piping

CAUTION

- Before piping make sure to clean away all chips, cutting oil, dust etc.
- When installing piping or fitting into a port, ensure that sealant material does not enter the port inside. When using seal tape, leave 1.5 to 2 threads exposed on the end of the pipe/fitting.

3.3 Lubrication

CAUTION

- The positioner has a fixed orifice and nozzle, which contain fine paths in them. Use filtered, dehydrated air and avoid the use of lubricators as this may cause malfunction of the positioner. Ensure that the air supply system is filtered to 5 micron.

3.4 Handling

CAUTION

- Avoid giving impact to the body and torque motor of the positioner, and giving excessive force to the armature because this leads to failure. Handle with care during transport and operation.
- If you leave the positioner at the operation site for a long time without using it, put the cover on it so that rain water does not enter the positioner. If the atmosphere is of high temperature or humidity, take measures to avoid condensation inside. The condensation control measures must be taken thoroughly for export shipment.
- Avoid setting the positioner near magnetic fields because the characteristics are affected.

4 MOUNTING

4.1 Type IP6000

4.1.1 Example of attaching to actuator

The Type IP6000 positioner is compatible with Typr IP600 in the attaching pitch.

If you are using IP600 already, the bracket for IP600 can be used to attach IP6000 to the actuator.

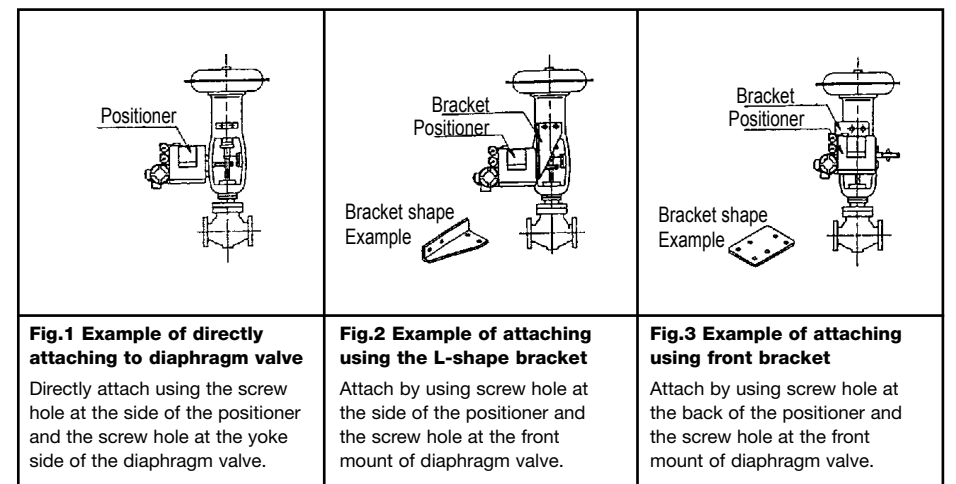

Fig.1 Example of directly attaching to diaphragm valve

Directly attach using the screw hole at the side of the positioner and the screw hole at the yoke side of the diaphragm valve.

Fig.2 Example of attaching using the L-shape bracket

Attach by using screw hole at the side of the positioner and the screw hole at the front mount of diaphragm valve.

Fig.3 Example of attaching using front bracket

Attach by using screw hole at the back of the positioner and the screw hole at the front mount of diaphragm valve.

4.1.2 Connection with external feedback lever

Fig.4 Attaching the feed back lever

(1) Attach to the position that the valve stem and lever form the **right angle** when the input signal is 50% (distribute evenly with 50% input signal set as the reference).
 (2) Attach to the position of the runout angle is **within the range of 10° to 30°**.
 (3) **To move the valve stem downward at the time of input current increase (normal actuation)**, attach to the position at which the tightening spring comes to the upper side of the connecting metal, as shown in Fig 11.
To move the valve stem upward (reverse actuation), turn-over the feedback lever and attach to the position at which the tightening spring comes to the lower side of connecting metal.

Fig.5 Use position for feedback lever

4.2 Type IP6100

4.2.1 Example of attaching to actuator

The Type IP6100 positioner is compatible with Typr IP610 in the attaching pitch.
 If you are using IP610 already, the bracket for IP610 can be used to attach IP6100 to the actuator.

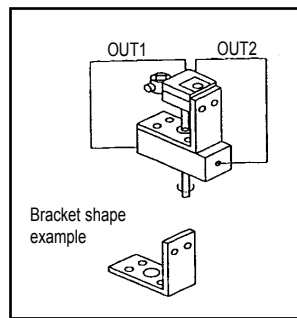

Fig.6 Example of attaching using the positioner side screw
 Attaching using the screw hole of a side of the positioner and the screw hole at the actuator top.

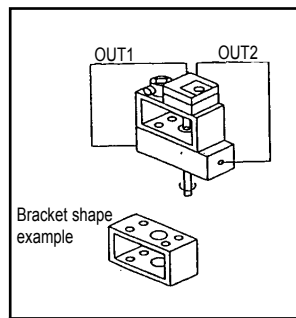

Fig.7 Example of attaching using the positioner back screw
 Attaching using the screw hole at the positioner back and the screw hole at the actuator top.

4.2.2 Connection with feedback shaft

(1) Attach to the position at which the positioner feed back shaft and the rotary actuator main shaft are **almost concentric** (range in which the spring pin of feed back shaft edge enters the hole of fork lever assembly shaft edge).
 (2) If the seration joint type for IP6100 is made in a special specification, it can be used for this connection.

Fig.8 Attaching the feed back lever

4.2.3 Cam attaching procedure

CAUTION

(1) Use the DA face of the cam to turn the actuator main shaft clockwise (viewed from the positioner front cover side) at the time of input signal increase. Use the RA face to turn it counter-clockwise (reverse actuation). Correctly attach the cam to the flange part of feed back shaft.
 (2) Attach the cam in the procedure of loosening the hexagonal nut with flange first, setting the using actuato to the starting position and then setting the cam reference line and the bearing contact point of span adjusting arm unit to the matching position.

(3) Do not apply the supply pressure when attaching the cam as otherwise it is very dangerous.
 (4) When the positioner is shipped out of our plant, the cam is tentatively tightened to the shaft. Be sure to firmly lock the cam to the lock nut [tightening torque 2.0 ~ 2.5 Nm].

Fig.9 Example of cam attaching

Table 2

	IP6000 (Lever type)	IP6100 (Rotary type)
	Single action	Double action
Normal actuation	Actuation: The stem moves in the arrow direction when the input current increases. 	Actuation: The actuator main shaft turns clockwise when the input signal increases.
Reverse actuation	Actuation: The stem moves in the arrow direction when the input current increases. (Reverse actuation using the normal actuation drive unit). 	Actuation: The actuator main shaft turns counter-clockwise when the input signal increases.

5 ADJUSTMENT

CAUTION

Check the following prior to start the adjustment.

- Check that the pipeline is correctly connected with the pressure supply port and OUT1 and OUT2 ports.
- Check that the actuator and positioner are sturdily connected.
- Check that the span adjusting lever of internal feed back (Type IP6000) is attached to the correct (normal or reverse) position. (Refer to Tables 2.)
- Check for locking of the auto/manual changeover screw of pilot valve (fully tightened in the clockwise direction).
- Check for correct use of the cam face (normal or reverse) in Type IP6100 and that the flange nut is firmly locked. (Refer to Table 2.)
- Check that the wires are connected correctly with the (+), (-) and grounding terminals.

	Type IP6000	Type IP6100
Zero point adjustment		 When the zero adjusting knob is turned clockwise, the starting point increases. When it is turned counter-clockwise, the starting point decreases.
Span adjustment		
Adjusting procedure	 (1) Set the input current to 0% (4mA DC in the standard specification) and turn the zero adjusting knob by hand to set it to the actuator starting point. (2) Then set the input current to 100% (20mA DC in the standard specification) and check the actuator stroke. At this point depending on the span is too large or too small, loosen the lock screw and adjust the span as shown in the illustration above. (3) Set the input current to 0% and conduct the zero point adjustment, as done in Step (1) again. (4) Repeat the above operations until the predetermined stroke of the actuator is obtained to the input current.	 (1) Set the input current to 0% (4mA DC in the standard specification) and turn the zero adjusting knob by hand to set it to the actuator starting point. (2) Then set the input current to 100% (20mA DC in the standard specification) and check the actuator stroke. At this point depending on the span is too large or too small, loosen the lock screw and adjust the span as shown in the illustration above. (3) Set the input current to 0% and conduct the zero point adjustment, as done in Step (1) again. (4) Repeat the above operations until the predetermined stroke of the actuator is obtained to the input current.

*1 When the span adjusting screw is turned clock-wise with a slothead(-) screwdriver, the span increases. When it is turned counter-clockwise, the span decreases.

*2 When the span adjusting screw is turned clock-wise with a slothead(-) screwdriver, the span decreases. When it is turned counter-clockwise, the span increases.

CAUTION

- For this positioner, span and zero point adjustment of each actuator is necessary. Adjustment shall be done based on each actuator size.
- Keep in mind that span and zero point adjustment interfere in each other.
- Characteristics changes due to change of mounting position, ambient temperature and supply pressure.
- If it takes along time until the operation after initial adjustment, check and adjust this product.
- Sensitive adjustment is effective for only double acting actuator.
- Manual change function is effective for single acting actuator which is controlled by using OUT1.

5.1 Electrical wiring

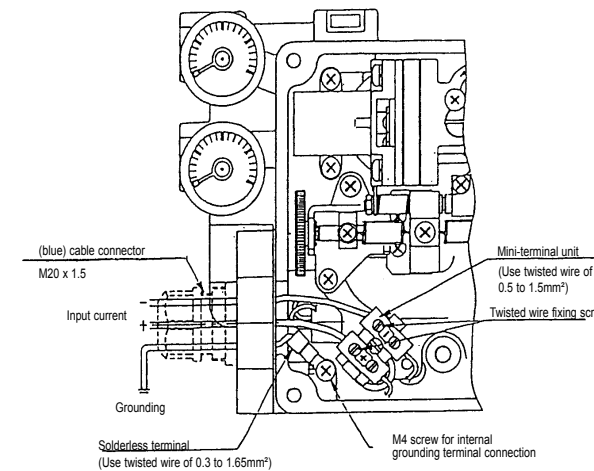

Connect the (+) and (-) output terminal of positioner with the (+) and (-) input terminal of positioner respectively. The input port of the electrical connection is equipped with a (blue) cable connector M20 x 1.5.

WARNING

To use as explosion protection specification may only be connected to a certified intrinsically safe electrical circuit with the following maximum values and connected to earth.

Parameters (current circuit)

$$U_i \leq 28V, I_i \leq 125mA, P_i \leq 1.2W, C_i \leq 0nF, L_i \leq 0mH$$

6 MAINTENANCE

WARNING

- After installation, repair and disassembly, connect compressed air and perform a proper function test and leak test. If bleed noise is louder than the initial state, or operation is abnormal, stop operation and check if installation is correct or not.
- Modification of Electrical construction is prohibited to maintain explosion proof certification.

CAUTION

- Check if supply air is clean or not. Inspect compressed air cleaning system periodically so that dust, oil and humidity, which can cause malfunction and failure of the unit, do not enter the equipment
- If handled improperly, compressed air can be dangerous. Maintenance and replacement of unit parts should only be performed by trained and experienced personnel for instrumentation equipment, as well as following the product specifications.
- Check the positioner once a year. When an excessively worn diaphragm, O-ring or other packing of any unit that has been damaged is found, replace with new ones. Treatment at an early stage is especially important if the positioner is used in a place of severe environment, such as coastal areas.
- Before removing the positioner for maintenance, or replacing unit parts after installation, ensure the supply pressure is shut off and all residual air pressure is released from the piping.
- When the fixed orifice is clogged with carbon particles or other material, remove the pilot valve Auto/Manual change over screw (built in fixed aperture) and clean it by inserting a 0.3mm diameter wire into the aperture.
- When you disassemble the pilot valve, coat the O-ring of the sliding section with grease. (Use the TORAY SILICONE SH45 grease.)
- Check for air leaks from the compressed air piping. Air leaks could lower the performance characteristics of the positioner. Air is normally discharged from a bleed port, but this is necessary air consumption based on the construction of the positioner, and is not an abnormality if the air consumption is within the specified range.

7 CONTACTS

To enquire about the product, please contact the following :-

SMC Corporation

AUSTRIA	(43) 2262-62 280	ITALY	(39) 02-92711
BELGIUM	(32) 3-355 1464	NETHERLANDS	(31) 20-531 8888
CZECH REP.	(420) 5-414 24611	NORWAY	(47) 67 12 90 20
DENMARK	(45) 70 25 29 00	POLAND	(48) 22-548 50 85
FINLAND	(358) 207 513513	PORTUGAL	(351) 2 610 89 22
FRANCE	(33) 1-64 76 1000	SPAIN	(34) 945-18 4100
GERMANY	(49) 6103 4020	SWEDEN	(46) 8-603 0700
GREECE	(30) 1- 342 6076	SWITZERLAND	(41) 52-396 3131
HUNGARY	(36) 1-371 1343	TURKEY	(90) 212 221 1512
IRELAND	(351) 1-403 9000	UK	(44) 1908-56 3888

Websites

SMC Corporation
 www.smcworld.com
 SMC Europe
 www.smceu.com