



Installation & Maintenance Manual

Fieldbus System - Handheld terminal

Type EX600-HT1



1. Safety Instructions

These safety instructions are intended to prevent hazardous situations and/or equipment damage.

These instructions indicate the level of potential hazard by label of "DANGER", "WARNING" or "CAUTION", followed by important safety information which must be carefully followed.

To ensure safety of personnel and equipment the safety instructions in this manual and the product catalogue must be observed, along with other relevant safety practices.

⚠ DANGER	In extreme conditions, there is a possible result of serious injury or loss of life.
⚠ WARNING	If instructions are not followed there is a possibility of serious injury or loss of life.
⚠ CAUTION	If instructions are not followed there is a possibility of injury or equipment damage.

⚠ WARNING

Do not disassemble, modify (including change of printed circuit board) or repair this product.
Injury or failure can result.

Do not operate the device with wet hands.
There is a risk of electric shock.

Do not operate the product beyond the specification range.
Do not use the product for flammable or harmful gases or liquids.
Fire, malfunction, or damage to the product can result.
Please confirm the specifications before use.

Do not operate the product in an environment where flammable or explosive gases may be present.
Fire or an explosion can result.
This product is not designed to be explosion proof.

The following instructions must be followed during maintenance:

- Turn off the power supply.
 - Stop the air supply, exhaust the residual pressure and make sure that the air is released to atmosphere before performing maintenance.
- Otherwise injury can result.

Do not apply pressure to the LCD display.
This may cause damage or injury.

The forced input/output function is used to change the signal status forcibly.
When operating this function, be sure to check the safety of the surroundings and the installation.
Otherwise injury or equipment damage could result.

Erroneous parameter setting can result in malfunction.
Be sure to confirm the settings.
Otherwise injury or equipment damage could result.

1. Safety Instructions (continued)

⚠ CAUTION

Perform a proper functional check after completing maintenance.
Stop operation if the equipment does not function properly.
Safety cannot be assured due to unexpected malfunction.

Switching the HOLD/ CLEAR function selection mode, will switch the operation of the input / output signal and emergency stop, so pay due attention to safety when setting.
There is a risk of injury and equipment damage.

When setting the parameters to the factory defaults, unpredictable operation of connected equipment may occur.
It is essential to carry out this operation paying attention to safety.
Otherwise injury or equipment damage could result.

2. How to Order

Refer to the catalogue or operation manual for this product.

3. Specifications

Refer to the catalogue or operation manual for this product.

4. Outline dimensions(mm)

Refer to the catalogue or operation manual for this product.

5. Names / Functions of individual Parts

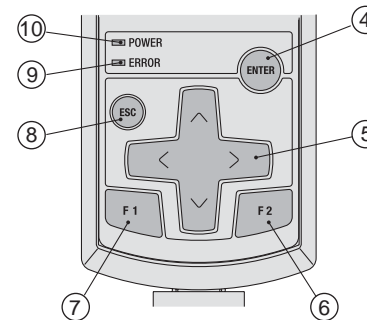
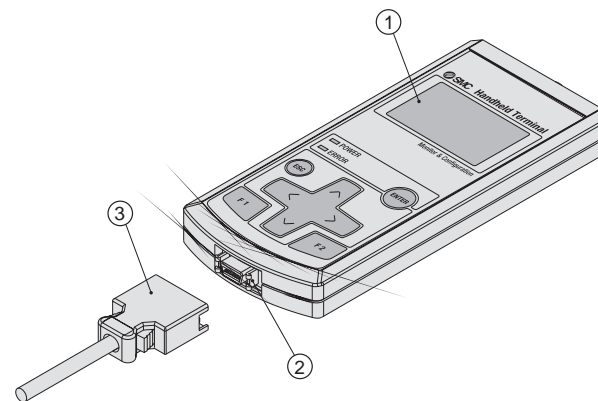

No.	Name	Description
1	LCD display	Displays the operation items and information about the unit.
2	Connector	Connector for Handheld Terminal cable.
3	Handheld Terminal cable	Cable to connect the SI Unit to the Handheld Terminal.
4	ENTER button (ENTER)	In selecting screen, this button is used for selecting the required item. In setting screen, pressing this button registers the selected contents.
5	Cursor move button (↑, ↓, ←, →)	This button is used to move the cursor in LCD display upward/downward and right/left direction. Select the required item using this button. Use this button to increase/decrease or turn ON/OFF the setting value.
6	F2 button (F2)	This button functions according to the indication or instruction displayed on the screen.
7	F1 button (F1)	
8	Escape button (ESC)	In selecting screen, this button is used to return to the previous screen. Pressing this button cancels the setting contents.
9	Error LED	The Error LED (Red) turns ON when EX600 diagnostics error occurs. (Refer to the "Troubleshooting" and "Error Code" section for further details.)
10	Power LED	The Power LED (Green) turns ON when the Handheld Terminal is connected with an EX600 SI Unit and power supply for Control/Input is ON.

6. Wiring

<Wiring Method (connecting Handheld Terminal connector)>
When inserting the connector into the Handheld Terminal, insert the connector straight in until it clicks into place.

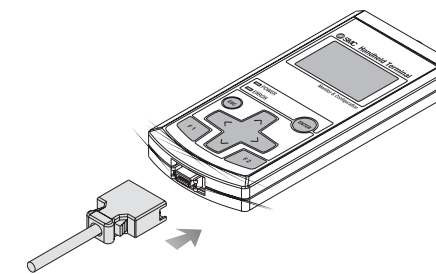

<Wiring Method (connecting to the SI Unit)>
The M12 cable connector is connected to the "connector for Handheld Terminal" on the SI Unit. The method of connecting the cable to the SI Unit is explained in the "<SPEEDCON Wiring method>" section.

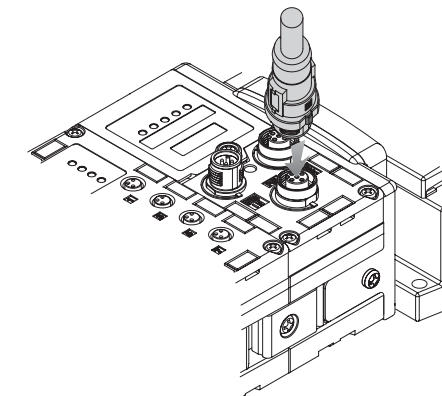

<SPEEDCON Wiring method>

- ① Set the projected portion of the cable connector metal ring (plug / socket) to the mark at cable end.

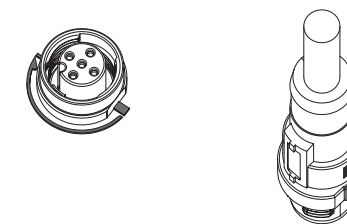

- ② Push the connector straight to insert it into the receptacle of the unit. If inserted without aligning the mark, the connector will not mate with the receptacle.

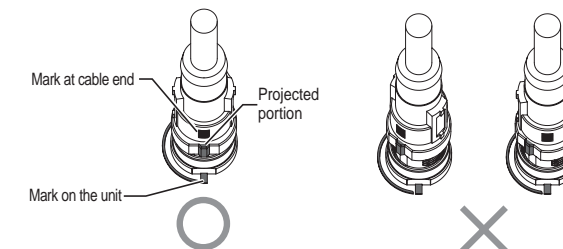

6. Wiring (continued)

- ③ Turn the connector clockwise. It stops when turned 1/4 turn. Turn it further. When the connector is turned 1/2 turn from the original position, the projected portion is set at the diagonal position to the mark and the turn is completed. Check that the connector is securely locked.
If the connector is turned excessively, it will become difficult to remove.

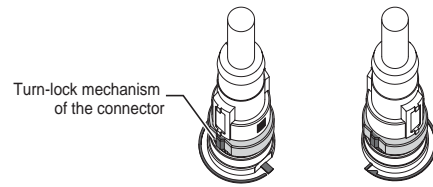

7. Setting

<Basic Operation>

① Turning ON the power

- (1) When the SI Unit and the Handheld Terminal are connected with the cable, the power is supplied to the Handheld Terminal.
- (2) The POWER LED (green) turns ON and the start up screen is displayed on the LCD display.
- (3) After about 2 seconds, the Main Menu screen is displayed.

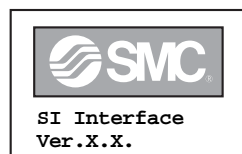

After
2 seconds

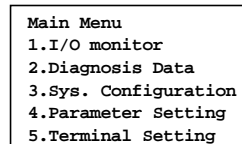

② Turning off the Power

- During Main Menu screen, remove the cable connected to the SI Unit.

Notes

- Be sure to put seal caps on any unused connectors of the EX600 SI Unit. Appropriate use of seal caps enables the unit to achieve IP67 protection.
- The cable can be removed only when the Handheld Terminal displays the Main Menu screen. Do not remove the cable while at any other screen, or this may cause equipment malfunction.

<Power Saving>

When the power supply is ON, and the button is pressed for 2 seconds or more the Handheld Terminal will enter power saving mode.

The LCD display will turn OFF. Pressing the button again will recover from the power saving mode.

7. Setting (continued)

<Main Menu>

The Handheld Terminal has five modes for the various functions. Each mode is composed of layers with more detailed contents enabling setting and checking of each item.

Main Menu	
1.	I/O monitor
2.	Diagnosis Data
3.	Sys. Configuration
4.	Parameter Setting
5.	Terminal Setting

Mode Selection Screen

No.	Mode	Description
1	I/O Monitor mode	This mode displays the I/O status of the unit and carries out forced I/O.
2	Diagnosis Data mode	This mode displays the I/O status of the unit, the detailed error contents and error log.
3	System Configuration mode	This mode is used to configure the following system operations: (1) Input the tag name of each unit. (2) Update the memorized information of manifold configuration. (3) Change the hold/clear function to SW setting of the SI unit or setting by the Handheld Terminal. (4) Clear the ON/OFF counter of each I/O Unit. (5) Reset the parameter of each unit to the factory default value. (6) Clear all error logs.
4	Parameter Setting mode	This mode is used to set each parameter type.
5	Terminal Setting mode	This mode is used to set the following: (1) Set the contrast of the LCD display screen. --> 9 levels (2) Set the brightness of the LCD display screen. --> 5 levels (3) Set the click sound level for button operation. --> 5 levels (4) Set the time before entering power saving mode when there is no operation. --> None, 1 min, 3 min, 7 min, 10 min (5) Cancel the operation settings of the Handheld Terminal and return to the initial setting values. (6) Change the password.

8. Trouble Shooting

Indication	Problem	Investigation method	Counter-measure
Power LED is OFF	EX600 Power supply voltage level for control / input is not within specification.	- Check if "PWR" LED on the SI Unit is green. - Confirm that the regulated power supply voltage is supplied to the endplate.	Supply voltage of 24V ± 10% to the power supply for control / input. Refer to the manual of the corresponding unit.
	The cable for the handheld terminal is defective.	- Confirm the Handheld terminal cable is connected correctly. - Confirm the integrity of the connection of the Handheld terminal cable.	- Reconnect the cable correctly. - Ensure the cable connections are secure.
LCD display is not active	Handheld terminal is in power save mode.	Press ESC button. Confirm that the LCD is active.	Same as left.
	LCD is damaged.	If LCD does not become active after initial checks above, LCD is damaged.	Stop operation and contact SMC sales office.
"Warning System access is not completed" is displayed on the LCD screen	The handheld terminal cable is defective.	- Confirm that the Handheld terminal cable is connected correctly. - Confirm there is no loose connection in the Handheld terminal cable.	- Reconnect the cable correctly. - Ensure the cable connections are secure.
	A connection between the units is defective.	Confirm if SI Unit "ST(M)" LED is green.	If LED is flashing red and green, there is a connection fault between the units. Re-make and then confirm the connection between the units.
[?] is displayed on the LCD screen.	Manifold configuration memory error has occurred.	Confirm if configuration memory is in active state and manifold configuration is correct.	Please refer to respective unit's operation manual to clear the error.
	Connection between the units is defective.	Confirm the SI Unit "ST(M)" LED is green.	If the LED is flashing red and green, there is a connection fault between the units. Re-make and then confirm the connection between the units.
ERROR LED is ON	EX600 diagnostic error has occurred.	Confirm error content through diagnostic data mode.	Refer to error code list and respective unit's operation manual for counter measure to the error.

9. Contact

AUSTRIA	(43) 2262 62280	NETHERLANDS	(31) 20 531 8888
BELGIUM	(32) 3 355 1464	NORWAY	(47) 67 12 90 20
CZECH REP.	(420) 541 424 611	POLAND	(48) 22 211 9600
DENMARK	(45) 7025 2900	PORTUGAL	(351) 21 471 1880
FINLAND	(358) 207 513513	SLOVAKIA	(421) 2 444 56725
FRANCE	(33) 1 6476 1000	SLOVENIA	(386) 73 885 412
GERMANY	(49) 6103 4020	SPAIN	(34) 945 184 100
GREECE	(30) 210 271 7265	SWEDEN	(46) 8 603 1200
HUNGARY	(36) 23 511 390	SWITZERLAND	(41) 52 396 3131
IRELAND	(353) 1 403 9000	UNITED KINGDOM	(44) 1908 563888
ITALY	(39) 02 92711		

SMC Corporation

URL <http://www.smcworld.com> (Global) <http://www.smceu.com> (Europe)

Specifications are subject to change without prior notice from the manufacturer.
© SMC Corporation All Rights Reserved.