



Installation & Maintenance Manual

EX510 Series Output unit

Series EX510-DY□ 3, DY□ 4



Safety Instructions

The body of unit and this manual contain the essential information for the protection of users and others from possible injury and property damage and to ensure correct handling.

Please check that you fully understand the definitions of the following messages (symbols) before going on to read the body of this manual, and always follow the instructions.

Please also read the instruction manuals etc. of related machines and understand the contents before use.

IMPORTANT MESSAGES

Read this manual and follow its instructions. Signal words such as WARNING, CAUTION and NOTE will be followed by important safety information that must be carefully reviewed.

⚠ WARNING	Indicates a potentially hazardous situation that could result in death or severe injury if you do not follow instructions.
⚠ CAUTION	Indicates a potentially hazardous situation that, if not avoided, may result in minor injury or moderate injury.
NOTE	Gives you helpful information.

⚠ WARNING

Do not disassemble, modify (including change of printed circuit board) or repair.

An injury or failure can result.

Do not operate beyond the specification range.

Fire, malfunction or damage can result.

Only use the unit after confirming the specification.

Do not use the product in an environment of flammable, explosive or corrosive gas.

Otherwise fire, explosion or corrosion can result.

This product is not explosion-proof type.

For use in interlock circuit:

- Provide double interlock system by adding different type of protection (such as mechanical protection).

- Check the product regularly to ensure proper operation. Otherwise accident caused by malfunction can result.

Before performing maintenance:

- Turn off the power supply.

- Stop air supply, exhaust compressed air in piping, and confirm the release to atmosphere.

Otherwise injury can result.

Safety Instructions (continued)

⚠ CAUTION

Conduct proper functional inspection after completing maintenance.

In the case of abnormality such as unit does not work normally, stop the operation. Otherwise safety cannot be assured due to unintended malfunction.

Provide grounding to improve safety and noise resistance of reduced wiring system.

Provide grounding as close to the unit as possible to shorten distance for grounding.

NOTE

The direct-current power supply to combine should be UL authorization power supply.

1. A limited voltage/current circuit which conforms to UL508.

A circuit to which power is supplied by the secondary coil of a transformer that meets the following conditions.

- Maximum voltage (with no load) : less than 30Vrms (42.4V peak)
- Maximum current : (1)less than 8A (including when short circuited)
(2)limited by circuit protector (such as fuse)
with the following ratings

No load voltage (V peak)	Max. current rating (A)
0 to 20 [V]	5.0
20 to 30 [V]	100/peak voltage

2. UL1310 Class 2 power supply unit or circuit of max. 30Vrms (42.4Vpeak) or less using a UL1585 Class 2 transformer as power source.

Follow the instructions given below when handling the reduced wiring system.

Failure to follow instructions may damage the unit.

- Operate the unit within the specified voltage range.
- Reserve a space for maintenance.
- Do not remove labels.
- Do not drop, hit or apply excessive shock to the product.
- Follow the specified tightening torque.
- Do not bend or apply tensile force to cables, or apply force by placing heavy load on them.
- Connect wires and cables correctly.
- Do not connect wires while the power is on.
- Do not lay wires or cables with power cable or high-voltage cable in the same wiring route.
- Verify the insulation of wiring.
- Separate power cables for solenoid valves from power cables for Input and control unit.
- Take proper measurements against noise such as noise filter when the reduced wiring system is incorporated in equipment or devices.
- Select the proper type of protection according to the environment of operation.
- Take sufficient shielding measures when installing at the following place.
 - (1) A place where noise due to static electricity is generated
 - (2) A place where electric field strength is high
 - (3) A place where there is radioactive irradiation
 - (4) A place near power line
- Do not use the product nearby a place where electric surges are generated.
- Use reduced wiring system equipped with surge absorber when a surge-generating load such as a solenoid valve is driven directly.
- Prevent foreign matter such as remnant of wires from entering this product.
- Do not expose the reduced wiring system to vibration and impact.
- Keep the specified ambient temperature range.
- Do not expose reduced wiring system to heat radiation from a heat source located nearby.
- Perform maintenance and check regularly.
- Perform a proper functional check.
- Do not use the product with chemicals such as benzene and thinner.

Model Indication Method

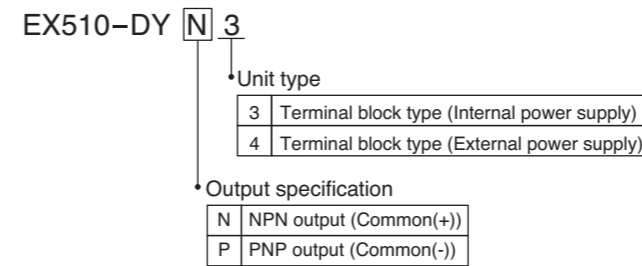

Dimensions (in mm)

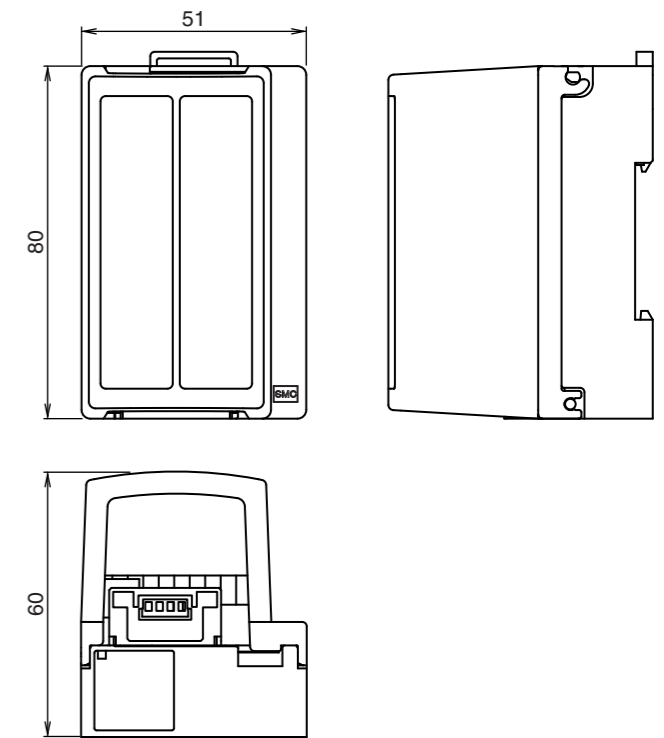

Specifications

Item	EX510-DYN3	EX510-DYP3	EX510-DYN4	EX510-DYP4
Output No.	NPN output	PNP output	NPN output	PNP output
Rated load voltage	24VDC			
Power supply type	Internal power supply (from GW unit)		External power supply (from power supply connector)	
Power supply acceptable wire	-		0.14 to 1.5mm ² (AWG16 to 26)	
Output point	16			
Output connector type	Spring type			
Output terminal acceptable wire	0.08 to 1.5mm ² (AWG16 to 28)			
Maximum load current	The following three requirements shall be satisfied. 1) 0.5A or less per point. 2) 1A or less per unit. 3) Total current from OUT0 to 7 is 1A or less. Total current from OUT8 to 15 is 1A or less.		The following three requirements shall be satisfied. 1) 0.5A or less per point. 2) 3A or less per unit. 3) Total current from OUT0 to 7 is 1.5A or less. Total current from OUT8 to 15 is 1.5A or less.	
Protection	Built-in protection circuit for short circuit			
Current consumption	50mA or less (Internal unit)			
Weight	130g (Include accessories)			

Name of Parts/Accessories

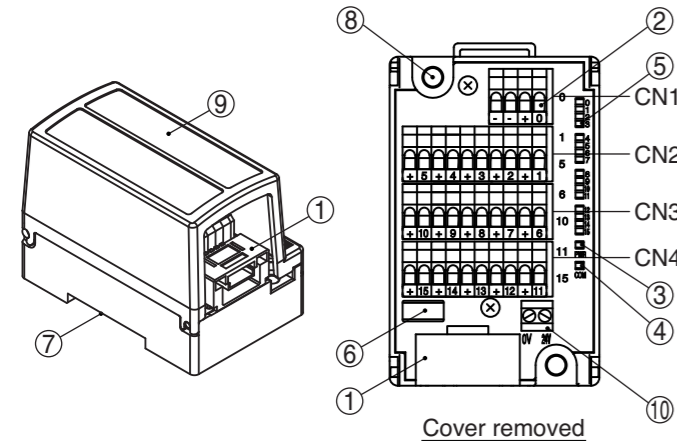

Accessories

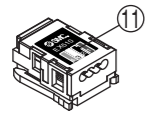

Branch connector
(2 pieces)
(EX510-LC1)

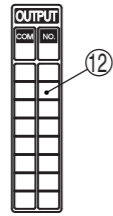

Marker plate

No.	Parts	Purpose
1	Branch connector at Output unit	Used to crimp branch connector (①) into branch cable (EX510-FC □ □) and connected them to GW unit.
2	Output terminal block	Used to connect output load, etc.
3	Power supply LED	Light ON : Power ON (normal) Light OFF : Power OFF
4	Communication LED	Light ON : Receiving data Light OFF : No communication data
5	Display LED	Light ON : Output signal ON Light OFF : Output signal OFF
6	Fuse	Fuse is replaceable.
7	Mounting slot	Used to mount DIN rail on the unit.
8	Mounting hole	The unit is mounted by two M4 screws.
9	Cover	Used to protect cable and provided with marker plate (②) on the top.
10	Terminal block for external power supply	Used to supply power. (EX510-DYN4, EX510-DYP4)

Installation

Mounted by screw

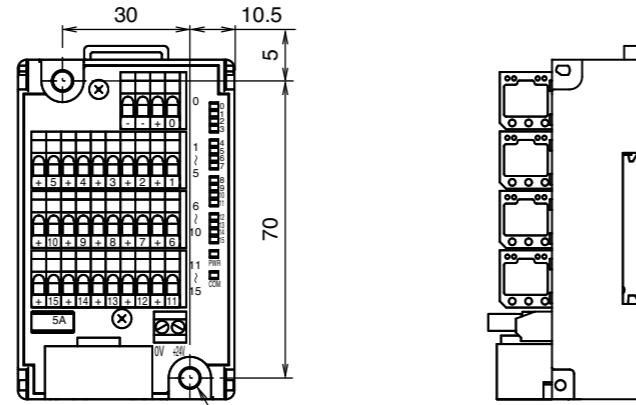

2 x M4
*Tightening torque : 0.8N·m

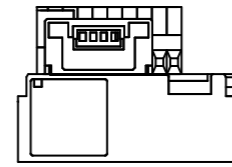

Cover removed

Mounted on DIN rail

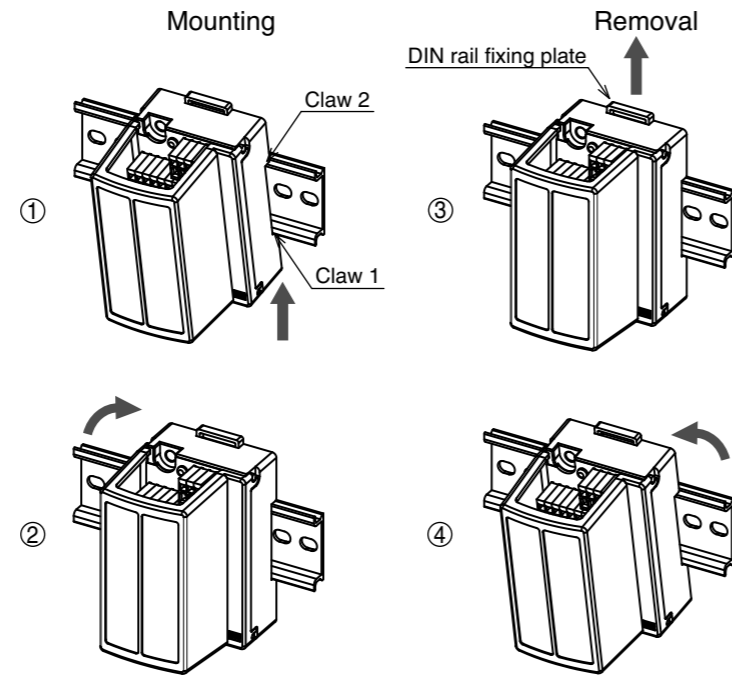

Put claw 1 at the body under DIN rail and push it upward. Push down claw 2 to the opposite rail until the claw clicks securely on rail.
(Mounting procedure ① and ②)

For removing, push up DIN rail fixing plate at the body with a flat screwdriver, and remove it by tilting claw 2 side forward.
(Removal procedure ③ and ④)

Wiring

EX510-DYN3 : Output unit for NPN (Internal power supply type)

Internal circuit

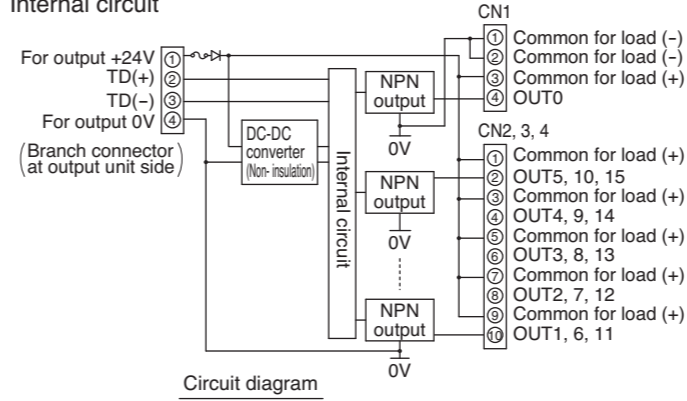

Circuit diagram

Terminal connector (CN1)

No.	Name	Function
1	COM	Common for load (-)
2	COM	Common for load (+)
3	COM	Common for load (+)
4	Output	OUT0

Terminal connector (CN2, CN3, CN4)

No.	Name	Function		
		CN2	CN3	CN4
1	COM	Common for load (+)		
2	Output	OUT5	OUT10	OUT15
3	COM	Common for load (+)		
4	Output	OUT4	OUT9	OUT14
5	COM	Common for load (+)		
6	Output	OUT3	OUT8	OUT13
7	COM	Common for load (+)		
8	Output	OUT2	OUT7	OUT12
9	COM	Common for load (+)		
10	Output	OUT1	OUT6	OUT11

EX510-DYN4 : Output unit for NPN (External power supply type)

Internal circuit

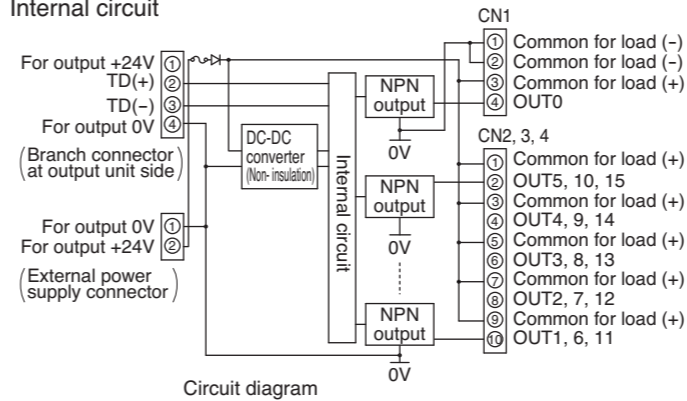

Circuit diagram

Terminal connector (CN1)

No.	Name	Function
1	COM	Common for load (-)
2	COM	Common for load (+)
3	COM	Common for load (+)
4	Output	OUT0

Terminal connector (CN2, CN3, CN4)

No.	Name	Function		
		CN2	CN3	CN4
1	COM	Common for load (+)		
2	Output	OUT5	OUT10	OUT15
3	COM	Common for load (+)		
4	Output	OUT4	OUT9	OUT14
5	COM	Common for load (+)		
6	Output	OUT3	OUT8	OUT13
7	COM	Common for load (+)		
8	Output	OUT2	OUT7	OUT12
9	COM	Common for load (+)		
10	Output	OUT1	OUT6	OUT11

Wiring (continued)

EX510-DYP3 : Output unit for PNP (Internal power supply type)

Internal circuit

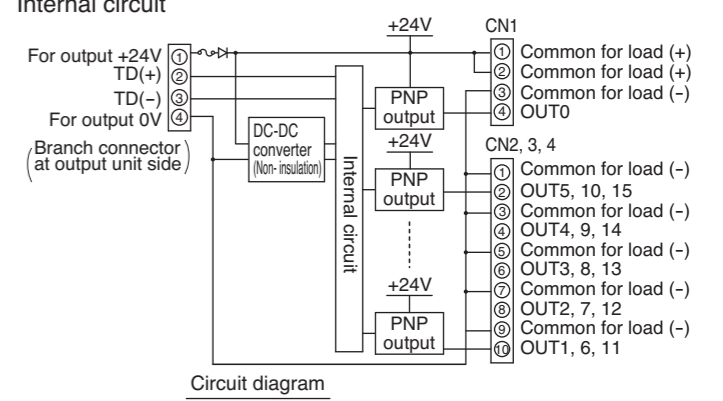

Circuit diagram

Terminal connector (CN1)

No.	Name	Function
1	COM	Common for load (+)
2	COM	Common for load (+)
3	COM	Common for load (-)
4	Output	OUT0

Terminal connector (CN2, CN3, CN4)

No.	Name	Function		
		CN2	CN3	CN4
1	COM	Common for load (-)		
2	Output	OUT5	OUT10	OUT15
3	COM	Common for load (-)		
4	Output	OUT4	OUT9	OUT14
5	COM	Common for load (-)		
6	Output	OUT3	OUT8	OUT13
7	COM	Common for load (-)		
8	Output	OUT2	OUT7	OUT12
9	COM	Common for load (-)		
10	Output	OUT1	OUT6	OUT11

EX510-DYP4 : Output unit for PNP (External power supply type)

Internal circuit

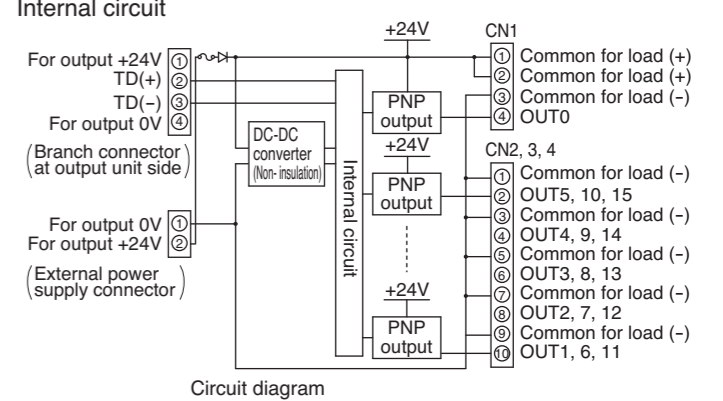

Circuit diagram

Terminal connector (CN1)

No.	Name	Function
1	COM	Common for load (+)
2	COM	Common for load (+)
3	COM	Common for load (-)
4	Output	OUT0

Terminal connector (CN2, CN3, CN4)

No.	Name	Function		
		CN2	CN3	CN4
1	COM	Common for load (-)		
2	Output	OUT5	OUT10	OUT15
3	COM	Common for load (-)		
4	Output	OUT4	OUT9	OUT14
5	COM	Common for load (-)		
6	Output	OUT3	OUT8	OUT13
7	COM	Common for load (-)		
8	Output	OUT2	OUT7	OUT12
9	COM	Common for load (-)		
10	Output	OUT1	OUT6	OUT11

Wiring (continued)

Branch wiring

Output unit and GW unit are connected with branch cable and branch connector.

Output unit have 2 branch connectors for each.

Pressure assembly of branch connector

The method of pressure assembly of branch connector is explained.

(1)Components

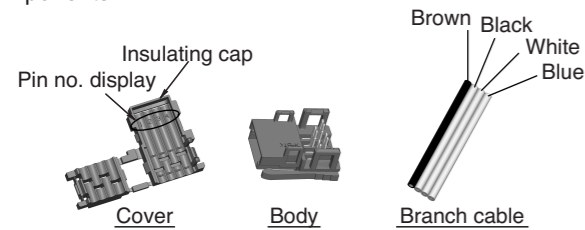

(2)Working procedure

① Set a branch cable to the cover.

1) Set the brown wire of the branch cable so that it comes to the pin #1.

2) Push the cable ends securely to the insulating cap at the cover.

3) Fold the cover so that the branch cable is trapped between the cover.

4) Fix the latch tip by inserting through the hole for fixing latch.

Note) Check the color of wire printed on the branch connector and the color of branch cables are same.

② Fix to the body tentatively.

Fit 4 latches on a body to 4 ditches on the cover, and press them until the latch engages to the level 1.

③ Press fitting

Press the cover to the body with suitable pliers.

④ Confirmation

Check that all 4 latches are fully engaged.

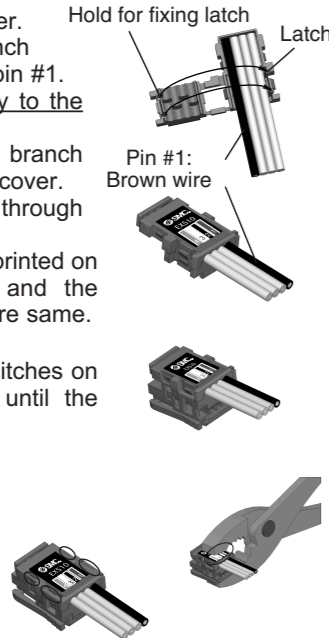

Wiring of load electric wire and terminal block connector

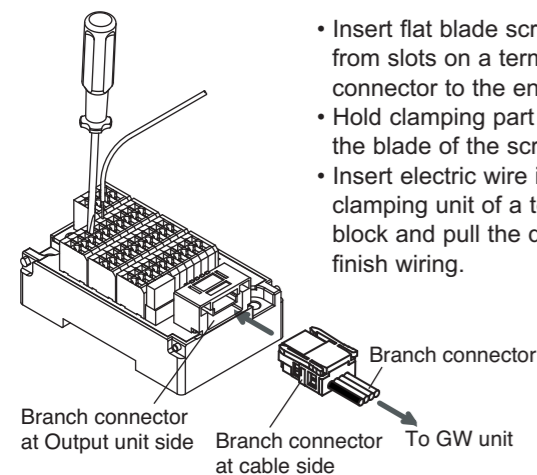

- Insert flat blade screw driver from slots on a terminal block connector to the end position.
- Hold clamping part opened with the blade of the screw driver.
- Insert electric wire into a clamping unit of a terminal block and pull the driver to finish wiring.

- Applicable electric wire size is 0.08 to 1.5mm² (AWG 16 to 28).
- Wire sheath stripped length is 5 to 6mm.
- Too long stripped length might expose conductor and cause insulation failure, and too short stripped length might get the sheath caught or make the conductor unclamped or clamped improperly resulting in contact failure or disconnection of electric wire.
- The flat blade screw driver shall have 2.5mm x 0.4mm blade end width and hold the clamp opened.

Wiring (continued)

The terminal block connector can be connected with the following electric wires.

- Solid wire, fine stranded wire, stranded conductor ultrasonically bonded, stranded conductor with ferrule, stranded conductor with pin terminal.

Wiring of power supply line and terminal block for external power supply

- Applicable electric wire size is 0.14 to 1.5mm² (AWG 16 to 26).
- Wire sheath stripped length is 4 to 6mm.
- Too long stripped length might expose conductor and cause insulation failure, and too short stripped length might get the sheath caught or make the conductor unclamped or clamped improperly resulting in contact failure or disconnection of electric wire.
- The flat blade screw driver shall have 2.5mm x 0.4mm blade end width and hold the clamp opened.
- Tightening torque for terminal block : 0.22Nm at minimum.

Maximum load current

Internal power supply type (EX510-DYN3, DYP3)

- The following three requirements shall be satisfied. : 1)0.5A or less per point. 2)1A or less per unit. 3)Total current from OUT0 to 7 and from OUT8 to 15 is 1A or less.

External power supply type (EX510-DYN4, DYP4)

- The following three requirements shall be satisfied. : 1)0.5A or less per point. 2)3A or less per unit. 3)Total current from OUT0 to 7 and from OUT8 to 15 is 1.5A or less.

For the load to the light, place an in-rush current restriction resistor to prevent potential fusing due to in-rush current

Contact

AUSTRIA	(43) 2262 62280	NETHERLANDS	(31) 20 531 8888
BELGIUM	(32) 3 355 1464	NORWAY	(47) 67 12 90 20
CZECH REP.	(420) 541 424 611	POLAND	(48) 22 211 9600
DENMARK	(45) 7025 2900	PORTUGAL	(351) 21 471 1880
FINLAND	(358) 207 513513	SLOVAKIA	(421) 2 444 56725
FRANCE	(33) 1 6476 1000	SLOVENIA	(386) 73 885 412
GERMANY	(49) 6103 4020	SPAIN	(34) 945 184 100
GREECE	(30) 210 271 7265	SWEDEN	(46) 8 603 1200
HUNGARY	(36) 23 511 390	SWITZERLAND	(41) 52 396 3131
IRELAND	(353) 1 403 9000	UNITED KINGDOM	(44) 1908 563888
ITALY	(39) 02 92711		

SMC Corporation

URL <http://www.smcworld.com> (Global) <http://www.smceu.com> (Europe)

Specifications are subject to change without prior notice from the manufacturer.
© SMC Corporation All Rights Reserved.