



# Installation & Maintenance Manual

## Reduced wiring system

### EX500 Series SI Unit

EX500-S□01

EX500-Q□01, EX500-Q□02



EMC Directive 89/336/EEC

EN61000-6-2:2001 Electromagnetic Compatibility (EMC). Generic standards - Immunity for industrial environments.

EN55011 A1+A2:2001 Limits and methods of measurement of radio disturbance characteristics of industrial, scientific and medical radio-frequency equipment and light industrial environments.

## Safety Instructions

The body of unit and this manual contain the essential information for the protection of users and others from possible injury and property damage and to ensure correct handling.

Please check that you fully understand the definitions of the following messages ( symbols ) before going on to read the body of this manual, and always follow the instructions.

Please also read the instruction manuals etc. of related machines and understand the contents before use.

### IMPORTANT MESSAGES

Read this manual and follow its instructions. Signal words such as WARNING, CAUTION and NOTE will be followed by important safety information that must be carefully reviewed.

**WARNING** Indicates a potentially hazardous situation that could result in death or severe injury if you do not follow instructions.

**CAUTION** Indicates a potentially hazardous situation that, if not avoided, may result in minor injury or moderate injury.

**NOTE** Gives you helpful information.

### WARNING

**Do not disassemble, modify ( including modification of printed circuit board ) or repair.**

Otherwise injury or failure can result.

**Do not operate beyond specification range.**

Otherwise fire, malfunction or damage to the reduced wiring system can result. Confirm the specifications before operation.

**Do not operate in atmosphere of flammable/explosive/corrosive gas.**

Otherwise fire, explosion or corrosion can result. This reduced wiring system is not explosion-proof type.

**For use in interlock circuit:**

• **Provide double interlock system by adding different type of protection**

( such as mechanical protection ).

• **Check that the interlock circuit is working normally.**

Otherwise accident caused by malfunction can result.

### Safety Instructions (continue)

**Before performing maintenance:**

- Turn off power supply.
  - Stop air supply, exhaust compressed air in piping, and confirm the release to atmosphere.
- Otherwise injury can result.

### CAUTION

**Conduct proper functional inspection after completing maintenance.**

In the case of abnormality such as unit does not work normally, stop the operation. Otherwise safety cannot be assured due to unintended malfunction.

**Provide grounding to improve safety and noise resistance of reduced wiring system.**

Provide grounding as close to the unit as possible to shorten distance for grounding.

### NOTE

• **Handling precautions**

Use the following UL-recognized DC power supply to combine with.

- UL508-compatible limited voltage/current circuit  
A circuit using the secondary coil of an insulating transformer that meets following conditions as power source.
  - Maximum voltage ( at no load ) : 30Vrms ( 42.4Vpeak ) or below
  - Maximum current:
    - ( 1 ) 8A or less ( including when short-circuited )
    - ( 2 ) When limited by the circuit protector ( such as fuse ) having the following rating.

No-Load Voltage ( Vpeak )	Max. Current Rating ( A )
0 to 20 [V]	5.0
Above 20 [V] to 30 [V]	100/peak voltage

- UL1310-compatible Class 2 power supply unit or circuit of max. 30Vrms ( 42.4Vpeak ) or less using a UL1585-compatible Class 2 transformer as power source. ( Class 2 circuit )

**Follow the instructions given below when handling your reduced wiring system. Otherwise a damage or failure to cause a malfunction can result.**

- Operate the reduced wiring system at the specified voltage.
- Reserve space for maintenance.
- Do not remove any name plate or label.
- Do not drop, hit or apply an excessive shock to the unit.
- Follow the specified tightening torque.
- Do not apply any excessive force to cables by repeated bending, tensioning or placing a heavy object on the cables.
- Connect wires and cables correctly.
- Do not perform any wiring work while the power is on.
- Do not use the reduced wiring system on the same wiring route as the power line or high voltage line.
- Confirm the insulation of wiring.
- Perform the power supply wiring by dividing into two lines — one is for power supply for output and the other is for power supply for input and controlling GW/SI.
- Take sufficient measures against noise such as noise filter when incorporating the reduced wiring system into a machine or equipment.
- Mount a terminal plug or a waterproof cap on each unused M12 connector for input/output ( communication connector, communication ports A - D, and power supply for input and controlling GW/SI ).
- Take sufficient shielding measures when operating the product in any of the following places.
  - ( 1 ) A place where noise due to static electricity etc. is generated
  - ( 2 ) A place of high electric field strength
  - ( 3 ) A place where exposure to radioactivity is possible
  - ( 4 ) A place near power cable
- Do not operate the product in a place where there is a source of surge.
- Use a surge absorbing element built-in type to directly drive the load that generates surge voltage such as solenoid valve.
- Prevent any foreign matter such as remnant of wires from getting inside the product when opening the station number switch protective cover.
- Install the reduced wiring system in a place free from vibration and impact.
- Operate the product in the specified ambient temperature range.
- Do not use in a place to be affected by the radiant heat from a surrounding heat source.
- Perform the maintenance regularly.
- Conduct an appropriate functional inspection after completing the maintenance.
- Do not use chemicals such as benzine and thinner to clean the product.

## Model Indication Method

### 1. SI unit for SV series valves

EX500 - S001

• GW Unit compatible

Nil	DeviceNet PROFIBUS-DP CC-Link
-X1	Remote I/O(RIO)

### 2. SI unit for VQC series valves

EX500 - Q101

• GW Unit compatible

0	NPN output ( + COM. )	Nil	DeviceNet PROFIBUS-DP CC-Link
1	PNP output ( - COM. )	-X1	Remote I/O(RIO)

• SI Unit mounting type

1	SI unit for mounting for only valve
2	SI unit for mounting for output block

## Outline with Dimensions (in mm)

### 1. SI unit for SV series valves ( EX500-S□01 )

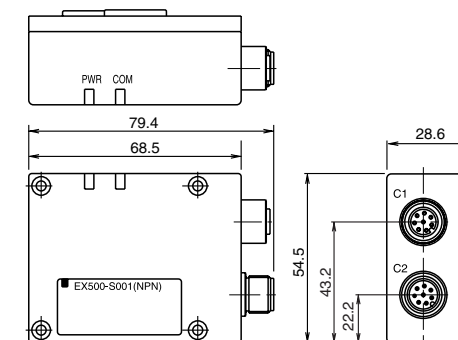

### 2. SI unit for VQC series valves ( EX500-Q□01 )

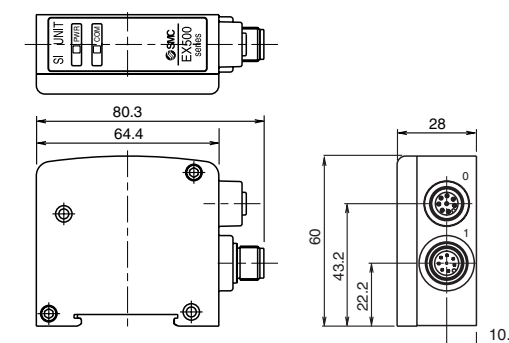

### ( EX500-Q□02 )

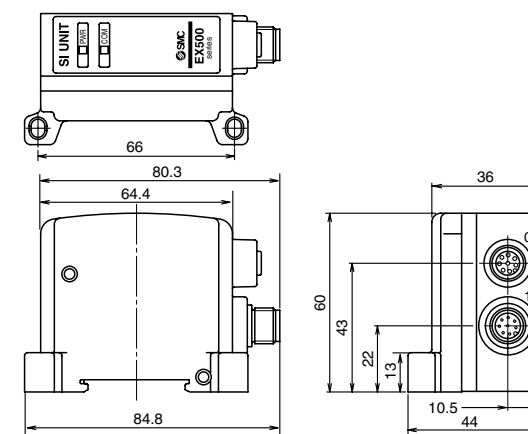

## Specification

### 1. SI unit for SV series valve ( EX500-S□01 )

Item	Specification	
Connected block	Solenoid valve ( single, double ) Relay output module ( 1-point output, 2- point output )	
Connected block stations	Double solenoid valve Relay output module ( 2-point output )	Max. 8 stations
	Single solenoid valve Relay output module ( 1-point output )	Max. 16 stations
Supply voltage for block	24VDC	
Supply current for block	Max. 0.65A	
Current consumption	100mA or less ( at rated voltage )	

### 2. SI unit for VQC series valve ( EX500-Q□0<sub>1</sub> )

Item	Specification	
Connected block	Solenoid valve ( single, double ) General purpose output block ( EX500-Q□02 only )	
Connected block stations	Double solenoid valve	Max. 8 stations
	Single solenoid valve	Max. 16 stations
	General purpose output block ( EX500-Q□02 only )	Max. 8 stations
Supply voltage for block	24VDC	
Supply current for block	Max. 0.75A	
Current consumption	100mA or less ( at rated voltage )	

## Names and Functions of individual parts

The SI unit is the unit to communicate with GW unit in combination with manifold valve. It can be used with SV series valves and VQC series valves.

In addition, this unit is able to operate solenoid valves, relays, etc. in combination with EX9 series general purpose output block. For how to use it, refer to section "EX9 Series General Purpose Output Block" in the Instruction manual of EX500.

### 1. SI unit for SV series valves ( EX500-S□01 )

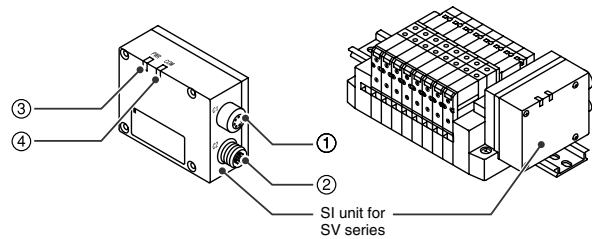

**Accessory:** Flat blade slot round head screw M3 X 28 4 pcs.

### 2. SI unit for VQC series valves ( EX500-Q□0 $\frac{1}{2}$ )

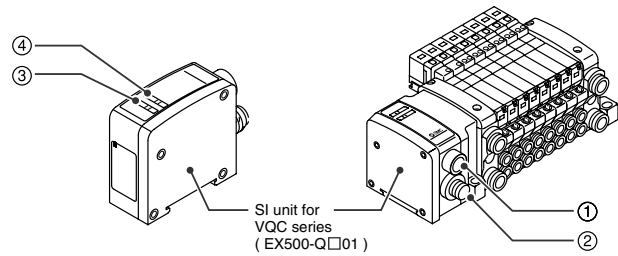

**Accessoris:**

**EX500-Q□0 $\frac{1}{2}$**  : Tie-rod 2pcs.

**EX500-Q□01**: Hexagon socket head cap screw (with spring washer)  
M3 X 10 2pcs.

**EX500-Q□02**: Hexagon socket head cap screw (with spring washer)  
M3 X 18 2pcs.

Common to EX500-S□01/EX500-Q□0 $\frac{1}{2}$

No.	Name	Application
1	Communication connector "C1" or "0"	Connects the branch cable to Input unit ( branch cable with M12 connector ). ( Note1 )
2	Communication connector "C2" or "1"	Connects the branch cable from GW unit ( branch cable with M12 connector ). ( Note1 )
3	Power LED	Indicates the power supply status. ( Note2 )
4	Communication LED	Indicates the communication status with GW unit: ( Note2 )

Note1: For wiring method, refer to subsection "Wiring" in this manual.

Note2: For display, refer to "Display" in this manual.

## Installation ( unit : mm )

### ●SI unit for SV series valves ( EX500-S□01 )

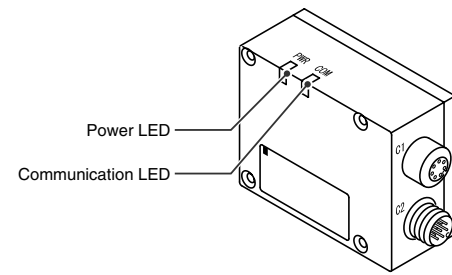

### ●SI unit for VQC series valves ( EX500-Q□0 $\frac{1}{2}$ )

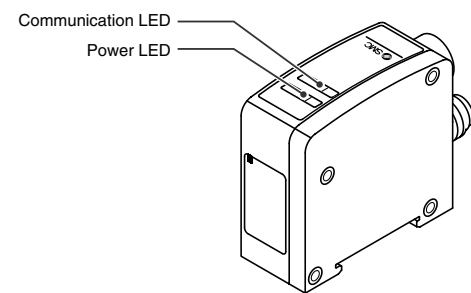

Common to EX500-S□01/EX500-Q□0 $\frac{1}{2}$

Display	Description
Power LED	Lights on: Power to solenoid valves/output is supplied at the specified voltage. Lights off: Power to solenoid valves/output is not supplied at the specified voltage. ( Voltage dropped to lower than 20V. )
Communication LED	Lights on: Receiving data from GW Lights off: No received data

## Mounting/Wiring

The mounting and removing methods of SI unit are as shown below.

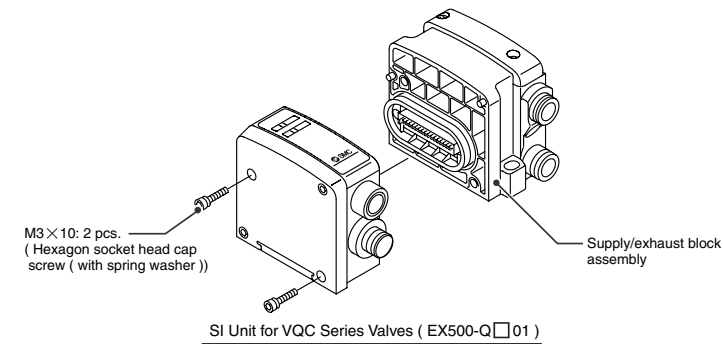
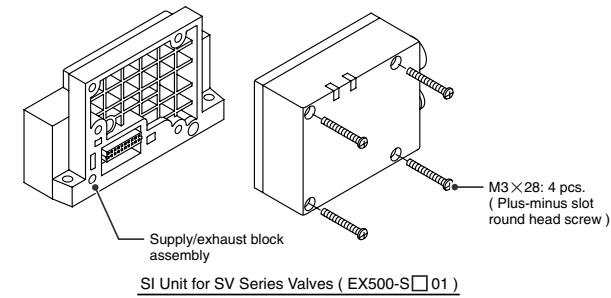

### NOTE

Holding with hand so that there will be no gap between SI unit and Air supply/exhaust block assembly, tighten the bolts. Be sure to tighten each bolt by specified tightening torque.  
( Tightening torque: 0.6Nm )

**Note 1** For branch wiring method, refer to subsection "Wiring" in the Instruction manual of EX500. As the power to output devices such as solenoid valve is supplied by branch wiring ( branch cable with M12 connector ), there is no need to supply power individually.

**Note 2** For mounting/installation methods of solenoid valve, manifold, etc., refer to the catalogs, instruction manuals, technical data, etc. of each valve series.  
When connecting general purpose output block only, refer to subsection "Mounting" in the Instruction Manual of EX500.

□ When you inquire about the product, please contact the following:

## SMC Corporation

URL <http://www.smcworld.com>

### Phone

AUSTRIA / (43) 2262-62 280  
BELGIUM / (32) 3-355 1464  
CZECH REP. / (420) 5-414 24611  
DENMARK / (45) 70 25 29 00  
FINLAND / (358) 9-859 580  
FRANCE / (33) 1-64 76 1000  
GERMANY / (49) 6103 4020  
GREECE / (30) 1- 342 6076  
HUNGARY / (36) 1-371 1343  
IRELAND / (353) 1-403 9000

ITALY / (39) 02-92711  
NETHERLANDS / (31) 20-531 8888  
NORWAY / (47) 67 12 90 20  
POLAND / (48) 22-548 50 85  
PORTUGAL / (351) 2 610 89 22  
SPAIN / (34) 945-18 4100  
SWEDEN / (46) 8-603 0700  
SWITZERLAND / (41) 52-396 3131  
TURKEY / (90) 212 221 1512  
UNITED KINGDOM / (44) 1908-56 3888