



Installation & Maintenance Manual

Reduced wiring system

EX500 Series Input Unit

EX500-IB1
EX500-IE □



EMC Directive 89/336/EEC

EN61000-6-2:2001 Electromagnetic Compatibility (EMC). Generic standards - Immunity for industrial environments.

EN55011 A1+A2:2001 Limits and methods of measurement of radio disturbance characteristics of industrial, scientific and medical radio-frequency equipment and light industrial environments.

Safety Instructions

The body of unit and this manual contain the essential information for the protection of users and others from possible injury and property damage and to ensure correct handling.

Please check that you fully understand the definitions of the following messages (symbols) before going on to read the body of this manual, and always follow the instructions.

Please also read the instruction manuals etc. of related machines and understand the contents before use.

IMPORTANT MESSAGES

Read this manual and follow its instructions. Signal words such as WARNING, CAUTION and NOTE will be followed by important safety information that must be carefully reviewed.

⚠ WARNING

Indicates a potentially hazardous situation that could result in death or severe injury if you do not follow instructions.

⚠ CAUTION

Indicates a potentially hazardous situation that, if not avoided, may result in minor injury or moderate injury.

NOTE

Gives you helpful information.

⚠ WARNING

Do not disassemble, modify (including modification of printed circuit board) or repair.

Otherwise injury or failure can result.

Do not operate beyond specification range.

Otherwise fire, malfunction or damage to the reduced wiring system can result.

Confirm the specifications before operation.

Do not operate in atmosphere of flammable/explosive/corrosive gas.

Otherwise fire, explosion or corrosion can result. This reduced wiring system is not explosion-proof type.

For use in interlock circuit:

• **Provide double interlock system by adding different type of protection**

(such as mechanical protection).

• **Check that the interlock circuit is working normally.**

Otherwise accident caused by malfunction can result.

Safety Instructions (continue)

Before performing maintenance:

- Turn off power supply.
- Stop air supply, exhaust compressed air in piping, and confirm the release to atmosphere.

Otherwise injury can result.

⚠ CAUTION

Conduct proper functional inspection after completing maintenance.

In the case of abnormality such as unit does not work normally, stop the operation. Otherwise safety cannot be assured due to unintended malfunction.

Provide grounding to improve safety and noise resistance of reduced wiring system.

Provide grounding as close to the unit as possible to shorten distance for grounding.

NOTE

● **Handling precautions**

Use the following UL-recognized DC power supply to combine with.

1. UL508-compatible limited voltage/current circuit

A circuit using the secondary coil of an insulating transformer that meets following conditions as power source.

- Maximum voltage (at no load) : 30Vrms (42.4Vpeak) or below
- Maximum current:
 - (1) 8A or less (including when short-circuited)
 - (2) When limited by the circuit protector (such as fuse) having the following rating.

No-Load Voltage (Vpeak)	Max. Current Rating (A)
0 to 20 [V]	5.0
Above 20 [V] to 30 [V]	100/peak voltage

2. UL1310-compatible Class 2 power supply unit or circuit of max. 30Vrms (42.4Vpeak) or less using a UL1585-compatible Class 2 transformer as power source. (Class 2 circuit)

Follow the instructions given below when handling your reduced wiring system. Otherwise a damage or failure to cause a malfunction can result.

- Operate the reduced wiring system at the specified voltage.
- Reserve space for maintenance.
- Do not remove any name plate or label.
- Do not drop, hit or apply an excessive shock to the unit.
- Follow the specified tightening torque.
- Do not apply any excessive force to cables by repeated bending, tensioning or placing a heavy object on the cables.
- Connect wires and cables correctly.
- Do not perform any wiring work while the power is on.
- Do not use the reduced wiring system on the same wiring route as the power line or high voltage line.
- Confirm the insulation of wiring.
- Perform the power supply wiring by dividing into two lines — one is for power supply for output and the other is for power supply for input and controlling GW/SI.
- Take sufficient measures against noise such as noise filter when incorporating the reduced wiring system into a machine or equipment.
- Mount a terminal plug or a waterproof cap on each unused M12 connector for input/output (communication connector, communication ports A - D, and power supply for input and controlling GW/SI).
- Take sufficient shielding measures when operating the product in any of the following places.
 - (1) A place where noise due to static electricity etc. is generated
 - (2) A place of high electric field strength
 - (3) A place where exposure to radioactivity is possible
 - (4) A place near power cable
- Do not operate the product in a place where there is a source of surge.
- Use a surge absorbing element built-in type to directly drive the load that generates surge voltage such as solenoid valve.
- Prevent any foreign matter such as remnant of wires from getting inside the product when opening the station number switch protective cover.
- Install the reduced wiring system in a place free from vibration and impact.
- Operate the product in the specified ambient temperature range.
- Do not use in a place to be affected by the radiant heat from a surrounding heat source.
- Perform the maintenance regularly.
- Conduct an appropriate functional inspection after completing the maintenance.
- Do not use chemicals such as benzine and thinner to clean the product.

Model Indication Method

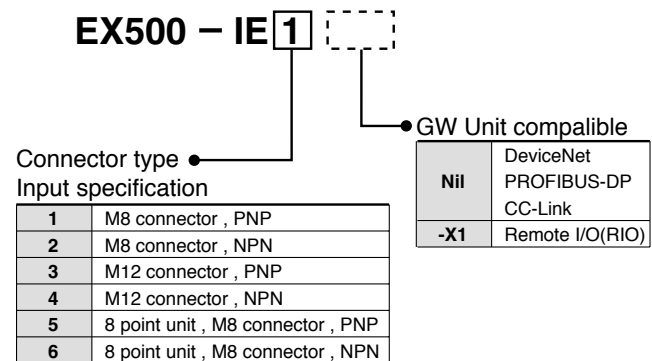
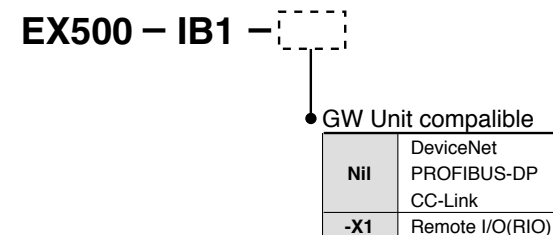
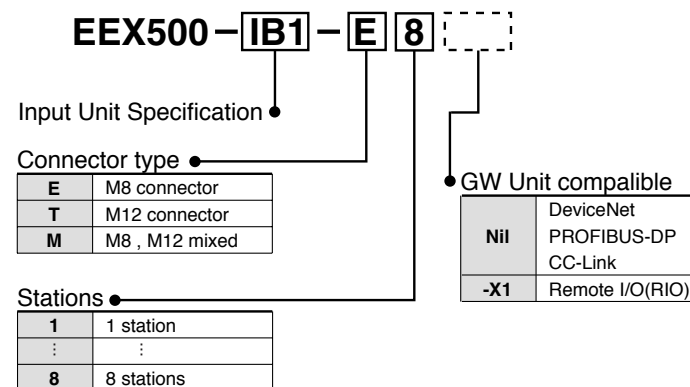

Outline with Dimensions (in mm)

● When only input blocks for M8 connector are connected

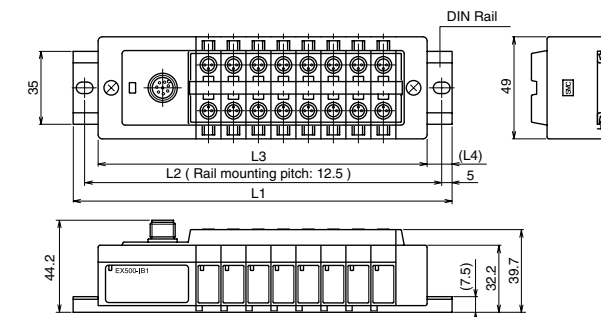

Stations	1	2	3	4	5	6	7	8
L1 [mm]: Rail length	98	110.5	123	135.5	148	160.5	173	185.5
L2 [mm]: Mounting pitch	87.5	100	112.5	125	137.5	150	162.5	175
L3 [mm]: Manifold length	74	86	98	110	122	134	146	158
L4 [mm]	12	12	12.5	12.5	13	13	13.5	13.5

● When only input blocks of 8-point-integrated type are connected

Stations	1	2
L1 [mm]: Rail length	135.5	185.5
aL2 [mm]: Mounting pitch	125	175
L3 [mm]: Manifold length	110	158
L4 [mm]	12.5	13.5

● When only input blocks for M12 connector are connected

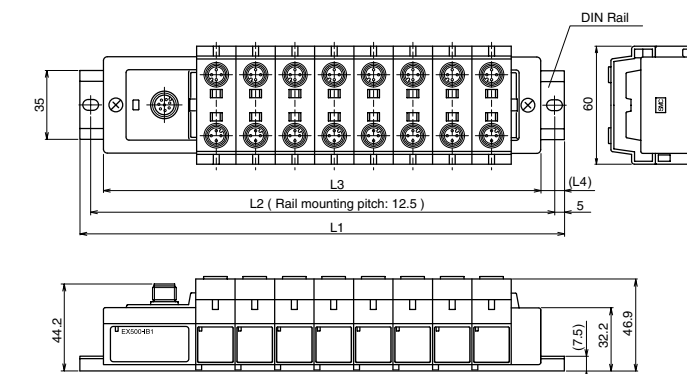

Stations	1	2	3	4	5	6	7	8
L1 [mm]: Rail length	110.5	123	148	173	185.5	210.5	223	248
L2 [mm]: Mounting pitch	100	112.5	137.5	162.5	175	200	212.5	237.5
L3 [mm]: Manifold length	82	102	122	142	162	182	202	222
L4 [mm]	12	12	12.5	12.5	13	13	13.5	13.5

Names and Functions of individual parts

The Input unit manifold consists of Input unit, input block (s), end block and DIN rail.
The input block up to 8 can be connected (16 points).
Any combination of input blocks (for M8 connector, M12 connector and 8-point-integrated type) is acceptable.

Note Do not mix sensor input specifications (PNP and NPN).

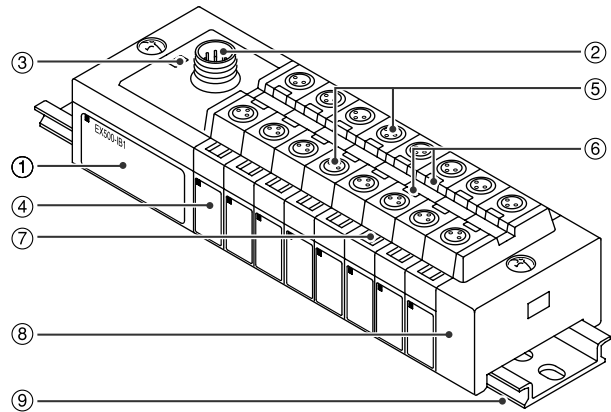

Figure shows the configuration when only input blocks for M8 connector are connected.

No.	Part name	Application
1	Input unit	Unit to communicate with GW unit or SI unit.
2	Communication connector	To be connected with branch cables from GW unit or SI unit (branch cable with M12 connector) (Note1)
3	Power LED	Indicates the power supply status. (Note2)
4	Input block	Unit for sensor signal input.
5	Sensor connector	Connects with sensor. (Note1)
6	Indicator LED	Indicates sensor signal status. (Note2)
7	Marker	To be used for writing input No. etc.
8	End block	Composes the end of Input unit manifold.
9	DIN rail	To be mounted with Input unit manifold.

Note1: For wiring method, refer to subsection "Wiring" in this manual.
Note2: For display, refer to "Display" in this manual.

Wiring

●Branch wiring

For wiring method, refer to subsection "Wiring" in the Instruction Manual of EX500.

To input devices such as sensor, the power is supplied through the branch wiring (branch cable with M12 connector). Therefore, there is no need to supply the power to them individually.

●Sensor wiring

Connect sensors to the sensor connectors of input block.

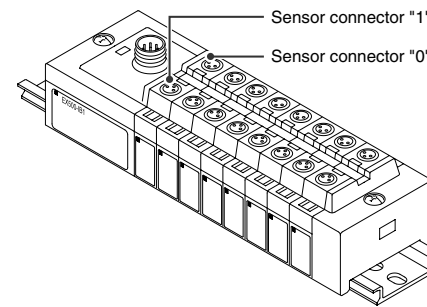

Pin layout of sensor connector

M8 connector (3-pin socket)	M12 connector (4-pin socket)
① Power supply (24VDC) ③ Power supply (0V) ④ Input	① Power supply (24VDC) ② (Input) (Note) ③ Power supply (0V) ④ Input

Note: Internal wiring of M12 input block and key position for mounting sensor connector

Specification

●Specifications for Input unit

Item	Specification
Connected block	Current source type input block (PNP input block) or Current sink type input block (NPN input block)
Connected block stations	Max. 8 blocks
Supply voltage for block	24VDC
Supply current for block	Max. 0.65A
Current consumption	100mA or less (at rated voltage)
Short circuit protection	Operates at 1A Typ. (Cuts power supply.) Can be reset by returning the power after cutting the power supply to input and control section of GW unit.

●Specifications for input block

Item	Specification	
	Current source type (PNP output)	Current sink type (NPN output)
Applicable sensor		
No. of input points	2 points/8 points (for M8 connector only)	
Rated voltage	24VDC	
Logical "1" input voltage	15V - 26.4V	0V - 8V
Logical "0" input voltage	0V - 5V	19V - 26.4V
Logical "1" input current	5mA Typ.	-5mA Typ.
Logical "0" input current	1.5mA	-1.5mA
Input delay time	1msec. or less	
Indicator LED	Green LED	
Insulation	N/A	
Supply current to sensor	Max. 480mA/Input unit manifold	

Installation (unit : mm)

- Connect each connector of Input unit, input blocks, and end block (portion indicated by arrow in the figure to the right).
- Holding with hands so that there will be no gap between blocks, place the jointed unit and blocks on DIN rail.
- Tighten the bolts of Input unit and end block to secure the jointed unit and blocks to DIN rail.
Be sure to tighten the bolts by proper tightening torque.
(Tightening torque: 0.6Nm)

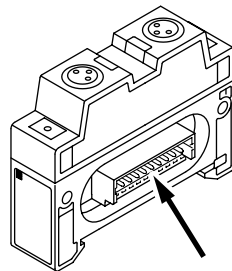

- No. 2 pins of M12 input block connectors are wired to each other's sensor signal input pins (No. 4 pins) internally.
- This wiring enables direct input of signals from two points combined into one cable through concentric connector etc.
- When connecting sensors, confirm the specification of output signal carefully. Otherwise malfunction can result.
- The key position for mounting sensor connector is as shown to the right. Consider this key position when selecting sensor.

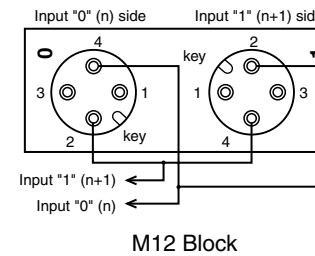

NOTE

Mount a waterproof cap on each unused connector of Input unit. The proper use of waterproof cap can achieve IP65 Enclosure. The waterproof caps are delivered together with each input block as accessories. (Tightening torque: 0.05Nm for M8 and 0.1Nm for M12)

Correspondence between input number and input block

Input block up to 8 can be connected (16 points).
Input numbers are 0 - 15 from Input unit side.

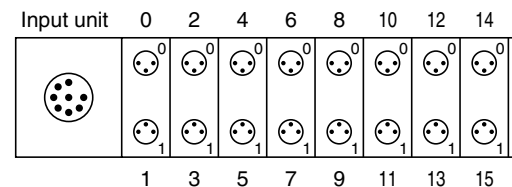

Display

●Settings for display

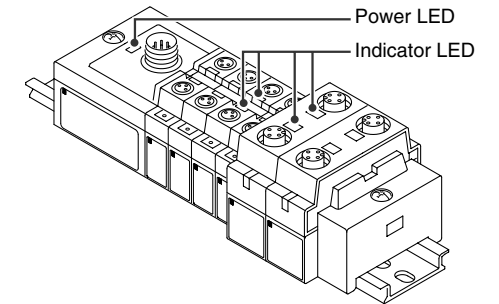

Display	Description
Power LED	Lights on: Power for input and controlling GW is supplied.
	Flashing: Under short circuit protection (abnormal status). As the short circuit protective function is operating, the power is not supplied. To cancel flashing, turn off and return the power to GW unit.
	Lights off: Power for input and controlling GW is not supplied.
Indicator LED	Lights on: Sensor signal input ON (logical "1")
	Lights off: Sensor signal input OFF (logical "0")

□ When you inquire about the product, please contact the following:

SMC Corporation

URL <http://www.smcworld.com>

Phone

AUSTRIA / (43) 2262-62 280	ITALY / (39) 02-92711
BELGIUM / (32) 3-355 1464	NETHERLANDS / (31) 20-531 8888
CZECH REP. / (420) 5-414 24611	NORWAY / (47) 67 12 90 20
DENMARK / (45) 70 25 29 00	POLAND / (48) 22-548 50 85
FINLAND / (358) 9-859 580	PORTUGAL / (351) 2 610 89 22
FRANCE / (33) 1-64 76 1000	SPAIN / (34) 945-18 4100
GERMANY / (49) 6103 4020	SWEDEN / (46) 8-603 0700
GREECE / (30) 1- 342 6076	SWITZERLAND / (41) 52-396 3131
HUNGARY / (36) 1-371 1343	TURKEY / (90) 212 221 1512
IRELAND / (353) 1-403 9000	UNITED KINGDOM / (44) 1908-56 3888