



Installation & Maintenance Manual

Reduced wiring system

CC-Link Compatible SI unit

Series EX180-SMJ1/EX180-SMJ1A



EMC Directive 89/336/EEC

EN61000-6-2:2001 Electromagnetic Compatibility (EMC). Generic standards - Immunity for industrial environments.

EN55011:1998+A1 Limits and methods of measurement of radio disturbance characteristics of industrial, scientific and medical radio-frequency equipment and light industrial environments.
:1999+A2
:2002

Safety Instructions

This manual contains essential information for the protection of users and others from possible injury and property damage. To ensure correct handling, please follow the instructions. Please check that you fully understand the meaning of the following messages (signs) before going on to read the text, and always follow the instructions. Please read the Installation & Maintenance Manual of related apparatus and understand it before operating the unit.

IMPORTANT MESSAGES

Read this manual and follow its instructions. Titles such as WARNING, CAUTION and NOTE, will be followed by important safety information which must be carefully followed.

⚠WARNING	Indicates a potentially hazardous situation which could result in death or serious injury if you do not follow instructions.
⚠CAUTION	Indicates a potentially hazardous situation which if not avoided, may result in minor injury or moderate injury.
NOTE	Gives you helpful information.

⚠WARNING

Do not disassemble, modify (including change of printed circuit board) or repair.

An injury or failure can result.

Do not operate beyond specification range.

Fire, malfunction or damage can result.

Only use the unit after confirming the specification.

Do not use the product in the environment with possible presence of flammable, explosive or corrosive gas with the product.

Fire, explosion or corrosion can result. This unit does not have an explosion proof construction.

Safety Instructions (continue)

⚠WARNING

These instructions must be followed when using the product in an interlocking circuit:

- Provide double interlocking by another system such as mechanical protection
 - Check the product regularly to ensure proper operation
- Otherwise a malfunction can cause an accident.

These instructions must be followed while carrying out maintenance work:

- Turn off the power supply
- Stop the supplied air, exhaust the residual pressure and verify the release of air before performing maintenance

Otherwise it can cause injury.

⚠CAUTION

Perform a proper functional check after completing maintenance work.

Please do not operate if there is any abnormality or error. There is a possibility that safety cannot be assured due to unexpected malfunction.

Provide grounding for correct operation and improved noise resistance of the unit.

The unit should be individually grounded with a short cable.

NOTE

The direct-current power supply should be a UL approved power supply.

- Limited voltage current circuit in accordance with UL508.
 A circuit which power is supplied by the secondary coil of a transformer that meets the following conditions.
 - Maximum voltage (with no load): less than 30Vrms (42.4V peak)
 - Maximum current : (1) less than 8A (including when short circuited)
 (2) limited by circuit protector (such as fuse) with the following ratings.

No load voltage (V peak)	Max. current rating (A)
0 to 20 [V]	5.0
Above 20 to 30 [V]	100/peak voltage

- A circuit using max. 30 Vrms or less (Class-2 circuit), which power is supplied by Class-2 power supply unit in accordance with UL1310 or Class-2 power supply unit in accordance with UL1585.

Follow the instructions given below when handling the unit. Failure to follow instructions may damage the unit.

- Operate the unit within the specified voltage range.
- Leave space around the unit for maintenance.
- Do not remove labels.
- Do not drop, hit or apply excessive shock to the unit.
- Follow the specified tightening torque.
- Do not bend or apply tensile force to cables, or apply force by placing heavy load on them.
- Connect wires and cables correctly.
- Do not connect wires while the power is on.
- Do not lay wires or cables with power cable or high-voltage cable in the same wiring route.
- Verify the insulation of wiring.

Safety Instructions (continue)

- Take proper measures against noise such as noise filter when the unit is incorporated in equipment or devices.
- Select the proper type of protection according to the environment of operation.
- Take sufficient shielding measures when installing at a following place.
 - (1) A place where noise due to static electricity is generated
 - (2) A place where electric field strength is high
 - (3) A place where there is radioactive irradiation
 - (4) A place near power line
- Do not use the unit close to a place where electric surges are generated.
- Use surge absorber built-in type unit when a surge-generating load such as a solenoid valve is driven directly.
- Prevent foreign matter such as remnant of wires from entering this product.
- Do not expose the unit to vibration and impact.
- Keep the specified ambient temperature range.
- Do not expose the unit to heat radiation from a heat source located nearby.
- Use a precision screwdriver with small flat blade when setting DIP switch.
- Close the cover to DIP switch side during power being supplied.
- Perform maintenance and check regularly.
- Perform a proper functional check.
- Do not clean the product with chemicals such as benzene and thinner.

Specification

Item	specifications					
Communication specification	Applicable system	CC-Link Ver. 1.10				
	Occupied station	1 station				
	Station number setting range	1 to 64				
	Station type	Remote I/O				
	Communication speed	156kbps	625kbps	2.5Mbps	5Mbps	10Mbps
	Cable length between stations	20cm or more				
Max. cable length	1200m	900m	400m	160m	100m	
Rated voltage	24VDC					
Power supply voltage range	SI unit controlling part's power supply : 24VDC ±10%					
	Power supply for solenoid valve : 24VDC +10%/-5% (Alarm for declined voltage under 20V)					
Output point	32 point					
Short-circuit protection	Applicable					
Current consumption	50mA or less					
Tolerant instantaneous interruption in power	1msec. or less					

Model Indication Method

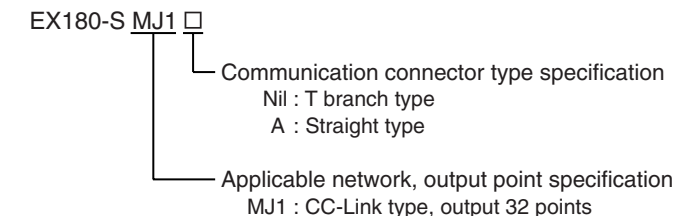

Environ. resistance	Enclosure	IP20
	Withstand voltage	500VAC 1min. (Between FG and external terminal)
	Insulation resistance	10MΩ or more (500VDC between FG and external terminal)
	Ambient temperature	Operation temperature : -10 °C to 50 °C Storage : -20 °C to 60 °C
	Ambient humidity	35% to 85%RH (No due condensation)
	Vibration resistance	5Hz to 9Hz (Constant amplitude) 1.75mm 9Hz to 150Hz (Constant acceleration) 4.9m/s ² 2 hrs for each X, Y, and Z direction (Per JIS B3502, IEC6113102)
	Impact resistance	147m/s ² 3 times for each X, Y, and Z direction (Per JIS B3502, IEC6113102)
	Operation atmosphere	No corrosive gas
	Standard	UL/CSA (E209424), CE marking (Note 1)
Weight	110g or less (Including accessory)	

Note 1 : EMC directive (89/336/EEC)
 EN61000-6-2 : 2001,
 EN55011 : 1998+A1 : 1999+A2 : 2002

Outline with Dimensions (in mm)

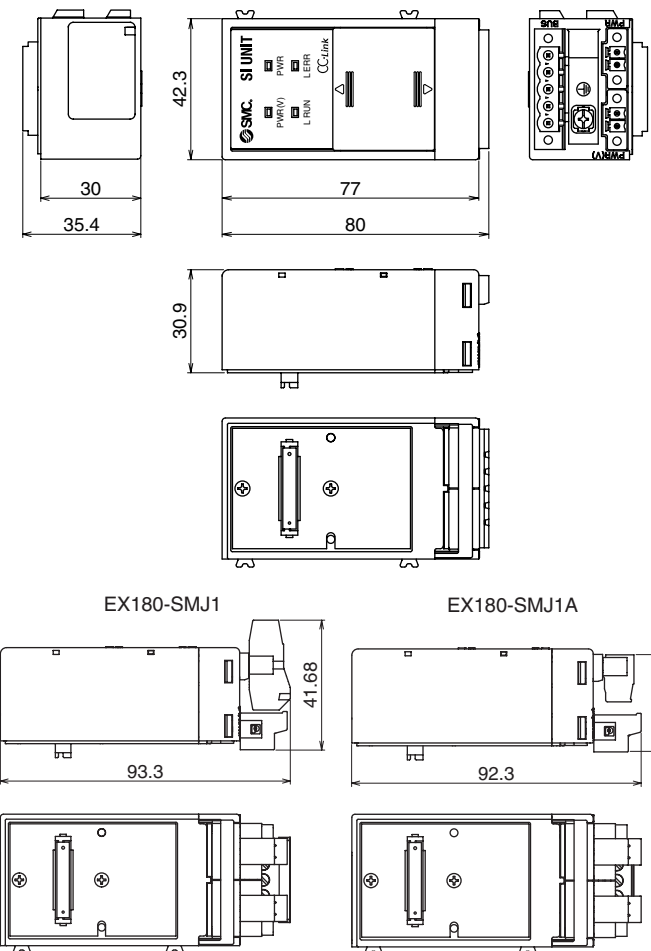

Name of Parts / Accessory

Communication connector for CC-Link (1 piece)
EX180-SMJ1 EX180-SMJ1A

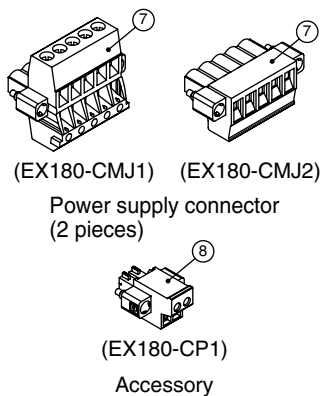

No.	Parts	Purpose
1	Communication socket (BUS)	Connect to CC-Link line with an accessory connector for CC-Link (7).
2	Power supply socket (PWR(V))	Supply the power for solenoid valve with an accessory connector (8).
3	Power supply socket (PWR)	Supply power for SI unit control with an accessory connector (9).
4	FG terminal	Used for functional ground.
5	Display	The status of the unit is indicated with LED.
6	Setting switch area	The station number and transmission speed are set.

Name of Parts / Accessory (continue)

Setting for Display

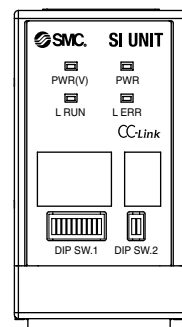

Display	Meaning
PWR (V)	The solenoid valve power supply is supplied with specified voltage : Light ON The solenoid valve power supply is not supplied with specified voltage : Light OFF
PWR	Power supply for the SI unit is supplied : Light ON Power supply for the SI unit is not supplied : Light OFF
L RUN	Normally communicating : Light ON Communication intercepted : Light OFF
L ERR	Communication error : Light ON Setting of station number setting/transmitting speed setting switch is changed whilst powered : Light ON (Blink with 0.4s interval) Normally communicating : Light OFF

Installation

Switch setting

- Make sure that switch setting is carried out with power supply turned off.
- Open the cover, and use a precision screwdriver with small flat blade when setting DIP switch, etc.

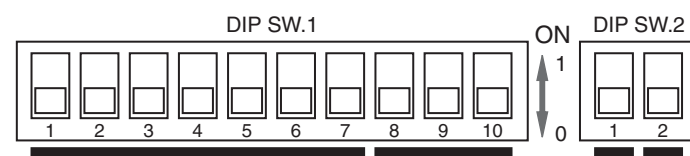

Setting of transmitting speed

Transmitting speed	No.8	No.9	No.10
156kbps	0	0	0
625kbps	0	0	1
2.5Mbps	0	1	0
5Mbps	0	1	1
10Mbps	1	0	0

HOLD/CLR setting

HOLD/CLR	No.1	Function
CLR	0	Output is cleared when an error happens.
HOLD	1	Output is held when an error happens.

Setting of terminating resistor

Terminating resistor	No.2	Function
With	1	The built-in terminating resistor (110Ω) is connected.
Without	0	Built-in terminating resistor not connected.

Station number setting

Station number	Tens digit (Switch No.)				Ones digit (Switch No.)		
	40 (No.1)	20 (No.2)	10 (No.3)	8 (No.4)	4 (No.5)	2 (No.6)	1 (No.7)
1	0	0	0	0	0	0	1
2	0	0	0	0	0	1	0
3	0	0	0	0	0	1	1
:	:	:	:	:	:	:	:
63	1	1	0	0	0	1	1
64	1	1	0	0	1	0	0

Wiring

Communication wiring

The method to connect CC-Link dedicated cable to the communication connector of SI unit for CC-Link is shown on the following table.

- (1) Make sure to connect the signal cables to designated pins.
(Refer to Fig.1) Tighten properly with 0.5 to 0.6[N•m] of tightening torque.
- (2) Make sure to connect a "Terminating resistor" between "DA" and "DB" of the unit at both ends of CC-Link system. (Refer to Fig.2) For CC-Link detected cable, use a cable with the same specifications. If a cable of another specification is used, the normal data transmission is not guaranteed.
- (3) The terminating resistor to be connected differs depending on the cable used for the CC-Link system. (Refer to the following table and Fig.3)

Cable type	Terminating resistor	
CC-Link detected cable	110Ω 1/2W (Brown, Brown, Brown)	Built-in terminating resistor (SW2-No.2) ON
CC-Link dedicated cable compatible to Ver.1.10		
CC-Link dedicated high performance cable	130Ω 1/2W (Brown, Orange, Brown)	

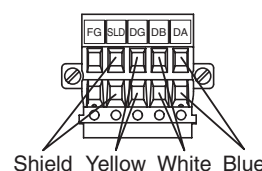

Fig.1

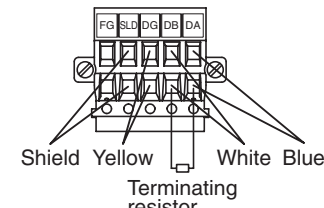

Fig.3

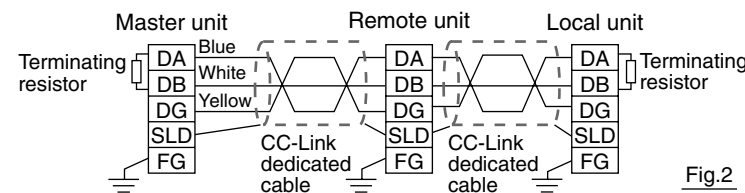

Fig.2

- (4) Refer to Fig.4 about how to connect to the unit.

Note
Connect the shield line of CC-Link dedicated cable to "SLD" of each unit.

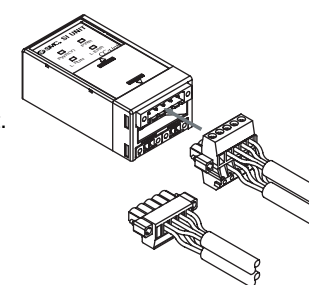

Fig.4

Wiring (continue)

Power supply wiring

Connect power supply wiring to the power supply connector (2pcs) which are delivered as accessory of the SI unit. Power supply structure consists of 2 systems, but it can be used with both single power supply and dual power supply.

Make sure to connect the designated pin. (Refer to Fig.5) Tighten properly with 0.22 to 0.25[N•m] of tightening torque.

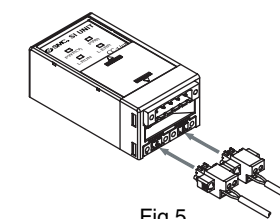
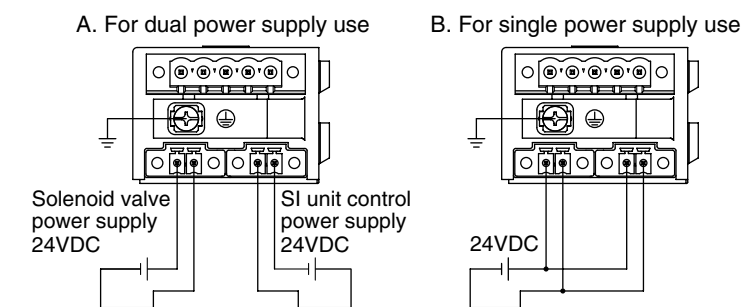

Fig.5

Note

D type grounding (Third-type grounding) should be performed for FG terminal.

(The connection to SLD and FG terminal is provided inside the unit.)



□ To enquire about the product, please contact the following.

SMC Corporation

URL <http://www.smcworld.com>

Phone
AUSTRIA / (43) 2262-62 280
BELGIUM / (32) 3-355 1464
CZECH REP. / (420) 5-414 24611
DENMARK / (45) 70 25 29 00
FINLAND / (358) 9-859 580
FRANCE / (33) 1-64 76 1000
GERMANY / (49) 6103 4020
GREECE / (30) 1- 342 6076
HUNGARY / (36) 1-371 1343
IRELAND / (353) 1-403 9000

ITALY / (39) 02-92711
NETHERLANDS / (31) 20-531 8888
NORWAY / (47) 67 12 90 20
POLAND / (48) 22-548 50 85
PORTUGAL / (351) 2 610 89 22
SPAIN / (34) 945-18 4100
SWEDEN / (46) 8-603 0700
SWITZERLAND / (41) 52-396 3131
TURKEY / (90) 212 221 1512
UNITED KINGDOM / (44) 1908-56 3888