



Installation & Maintenance Manual

Reduced wiring system

DeviceNet Compatible SI unit

Series EX180-SDN※□



Safety Instructions

This manual contains essential information for the protection of users and others from possible injury and property damage.

To ensure correct handling, please follow the instructions.

Please check that you fully understand the meaning of the following messages (signs) before going on to read the text, and always follow the instructions.

Please read the Installation & Maintenance Manual of related apparatus and understand it before operating the unit.

IMPORTANT MESSAGES

Read this manual and follow its instructions.

Titles such as DANGER, WARNING, CAUTION and NOTE, will be followed by important safety information which must be carefully followed.

⚠ WARNING	Indicates a potentially hazardous situation which could result in death or serious injury if you do not follow instructions.
⚠ CAUTION	Indicates a potentially hazardous situation which if not avoided, may result in minor injury or moderate injury.
NOTE	Gives you helpful information.

⚠ WARNING

Do not disassemble, modify (including change of printed circuit board) or repair.

An injury or failure can result.

Do not operate beyond specification range.

Fire, malfunction or damage can result.

Only use the unit after confirming the specification.

Do not use the product in the environment with possible presence of flammable, explosive or corrosive gas with the product.

Fire, explosion or corrosion can result. This unit does not have an explosion proof construction.

These instructions must be followed when using the product in an interlocking circuit:

- Provide double interlocking by another system such as mechanical protection
- Check the product regularly to ensure proper operation

Otherwise a malfunction can cause an accident.

These instructions must be followed while carrying out maintenance work:

- Turn off the power supply
- Stop the supplied air, exhaust the residual pressure and verify the release of air before performing maintenance

Otherwise it can cause injury.

⚠ CAUTION

Perform a performance inspection after completing the maintenance check.

Please do not use if there is any error.

There is a possibility that safety cannot be secured due to the unintentional malfunction.

Safety Instructions (continue)

⚠ CAUTION

Provide grounding for correct operation and improved noise resistance of the unit.

The unit should be individually grounded with a short cable.

NOTE

The direct-current power supply should be a UL approved power supply.

- Limited voltage current circuit in accordance with UL508.
A circuit which power is supplied by the secondary coil of a transformer that meets the following conditions.
 - Maximum voltage (with no load): less than 30Vrms (42.4V peak)
- Maximum current : (1) less than 8A
(including when short circuited)
(2) limited by circuit protector (such as fuse) with the following ratings.

No load voltage (V peak)	Max. current rating (A)
0 to 20 [V]	5.0
Above 20 to 30 [V]	100/peak voltage

- A circuit using max. 30 Vrms or less (Class-2 circuit), which power is supplied by Class-2 power supply unit in accordance with UL1310 or Class-2 power supply unit in accordance with UL1585.

Follow the instructions given below when handling the unit.

Failure to follow instructions may damage the unit.

- Operate the unit within the specified voltage range.
- Leave space around the unit for maintenance.
- Do not remove labels.
- Do not drop, hit or apply excessive shock to the unit.
- Follow the specified tightening torque.

- Do not bend or apply tensile force to cables, or apply force by placing heavy load on them.
- Connect wires and cables correctly.
- Do not connect wires while the power is on.
- Do not lay wires or cables with power cable or high-voltage cable in the same wiring route.
- Verify the insulation of wiring.
- Take proper measurements against noise such as noise filter when the unit is incorporated in equipment or devices.
- Select the proper type of protection according to the environment of operation.
 - (1) A place where noise due to static electricity is generated
 - (2) A place where electric field strength is high
 - (3) A place where there is radioactive irradiation
 - (4) A place near power line
- Do not use the unit close to a place where electric surges are generated.
- Use surge absorber built-in type unit when a surge-generating load such as a solenoid valve is driven directly.
- Prevent foreign matter such as remnant of wires from entering this product.
- Do not expose the unit to vibration and impact.
- Keep the specified ambient temperature range.
- Do not expose the unit to heat radiation from a heat source located nearby.
- Use a precision screwdriver with small flat blade when setting DIP switch.
- Close the cover to DIP switch side during power being supplied.
- Perform maintenance and check regularly.
- Perform a proper functional check.
- Do not clean the product with chemicals such as benzene and thinner.

Model Indication Method

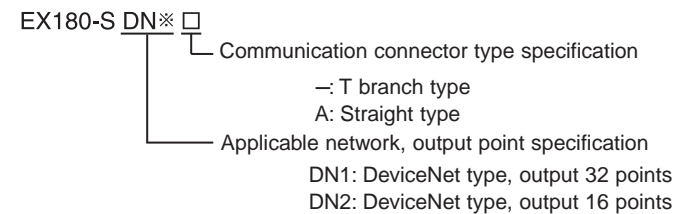

Outline with Dimensions (in mm)

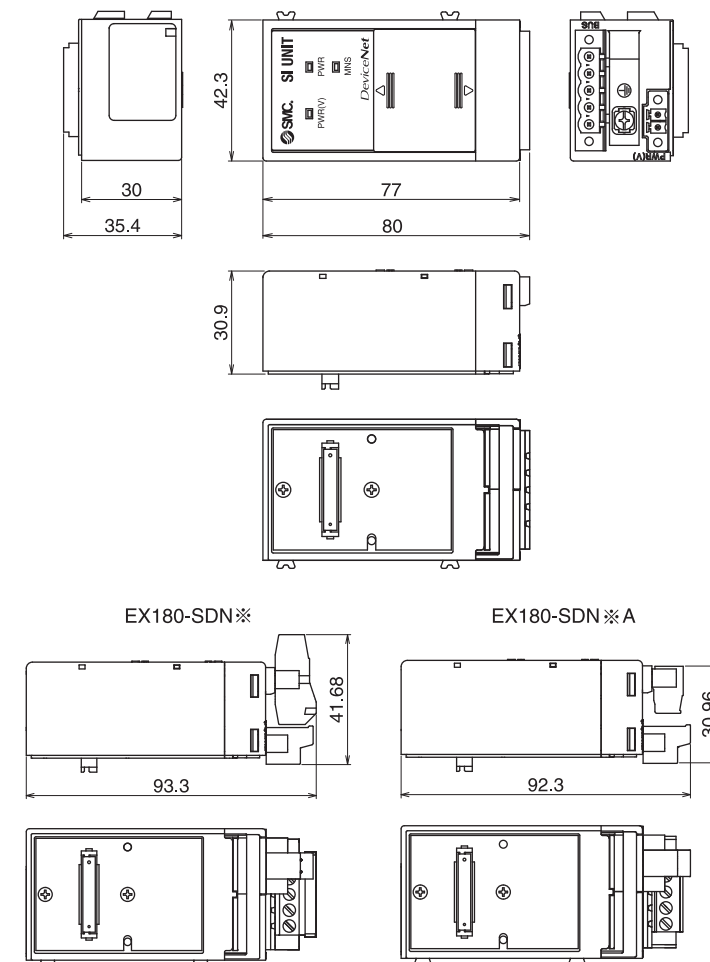

Specification

General specification

Item	Specifications	
Rated voltage	24VDC	
Power supply voltage range	Power supply for DeviceNet : 11VDC to 25VDC Power supply for solenoid valve : 24VDC +10%/ -5%	
Output points	EX180-SDN1, SDN1A : 32 points EX180-SDN2, SDN2A : 16 points	
Short circuit protection	Provided	
Current consumption	70mA or less	
Tolerant instantaneous power failure	10msec. or less	
Environment proof	Enclosure	IP20
	Withstand voltage	500VAC 1min. (Between FG and external terminal block)
	Insulation resistance	10MΩ or more (500VDC, between FG and external terminal block)
	Ambient temperature	Operating temperature : -10°C to +50°C Storage : -20°C to +60°C
	Ambient humidity	35% to 85%RH (no dew concentration)
	Vibration proof	5Hz to 9Hz (constant amplitude) 1.75mm 9Hz to 150Hz (constant acceleration) 4.9m/s ² Practice the vibration test as per JIS B3502 and IEC61131-2 to X, Y, and Z directions for 3 times each
Shock resistant	147m/s ² Practice the shock test as per JIS B3502 and IEC61131-2 to X, Y, and Z directions for 3 times each	
Atmosphere	No corrosive gas	
Standards	UL/CSA (E209424), CE marking	
Weight	110g or less (including accessories)	

Communication specification

Item	Specifications	
Applicable system	Device Net Volume1 (Edition2.1) Volume3 (Edition1.1)	
Slave type	Group2 Only Server	
Device type	27 (Pneumatic valve)	
Product code	101 : EX180-SDN1, SDN1A 106 : EX180-SDN2, SDN2A	
Vendor ID	7 (SMC Corp.)	
Applicable message	Duplicate MAC ID Check Message Unconnected Explicit Message Explicit Message Poll I/O Message COS/Cyclic I/O Message	
Setting range of MAC ID	0 to 63	
Communication speed	125kbps 250kbps 500kbps	
Maximum cable length for network	Thick cable	500m or less 250m or less 100m or less
	Thin cable	100m or less
Whole length of branch cable	156m or less 78m or less 39m or less	
	Note : The maximum length of each branch cable is 6m.	
Occupied byte	EX180-SDN1, SDN1A : 4 bytes for output, 0 byte for input EX180-SDN2, SDN2A : 2 bytes for output, 0 byte for input	

Names and Functions of Individual Parts

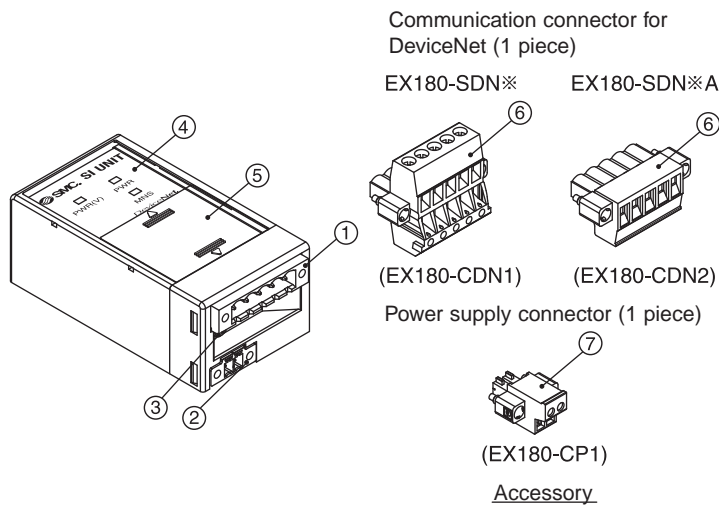

No.	Parts	Purpose
1	Communication socket (BUS)	Connect to DeviceNet line with an accessory connector for DeviceNet (⑥).
2	Power supply socket (PWR(V))	Supply the power for solenoid valve with an accessory connector (⑦).
3	FG terminal	Used for functional ground.
4	Display	The status of the unit is indicated with LED.
5	Setting switch area	MAC ID and baud rate are set.

Setting for display

Display	Function
PWR (V)	The solenoid valve power supply is supplied with specified voltage: Lights on The solenoid valve power supply is not supplied with specified voltage: Lights off
PWR	Power supply for the DeviceNet communication is supplied: Lights on Power supply for the DeviceNet communication is not supplied: Lights off
MNS	The power for DeviceNet communication is cut, or during off-line status or duplication check for MAC ID: Lights off While waiting for I/O connection (with on-line status): Green blinks When I/O connection is established (with on-line status): Green lights on On I/O connection • time out (slight communication error): Red blinks On MAC ID duplication error or BUS OFF error (serious communication error): Red lights on

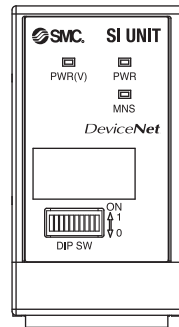

Installation

Switch setting

- Make sure that switch setting is done with power supply turned off.
- Open the cover, and use a precision screwdriver with small flat blade when setting DIP switch, etc.

DIP SW

ON 1
0

Baud rate setting

Baud rate	No. 7	No. 8
125kbps	0	0
250kbps	1	0
500kbps	0	1
Invalid	1	1

The setting is all OFF at shipping, and the baud rate is 125 kbps.

HOLD/CLR setting

HOLD/CLR	No. 9	Description
HOLD	1	Output is held when a communication error happens.
CLR	0	Output is cleared when a communication error happens.

The setting is OFF at shipping, and it is set at CLR mode.

SW/HW mode setting

SW/HW	No. 10	Setting status
SW	1	Setting for MAC ID and baud rate are done via a network. *No. 1 to No. 8 of DIP SW will be invalid.
HW	0	Setting for MAC ID and baud rate are done with No. 1 to No. 8 of DIP SW.

The setting is OFF at shipping, and it is in HW mode.

MAC ID setting

MAC ID setting	No. 1	No. 2	No. 3	No. 4	No. 5	No. 6
#0	0	0	0	0	0	0
#1	1	0	0	0	0	0
#2	0	1	0	0	0	0
⋮	⋮	⋮	⋮	⋮	⋮	⋮
#62	0	1	1	1	1	1
#63	1	1	1	1	1	1

The setting is all ON at shipping, and MAC ID is set at 63. Set the MAC ID in the range between 0 and 63.

Internal Circuit and Wiring

Internal circuit

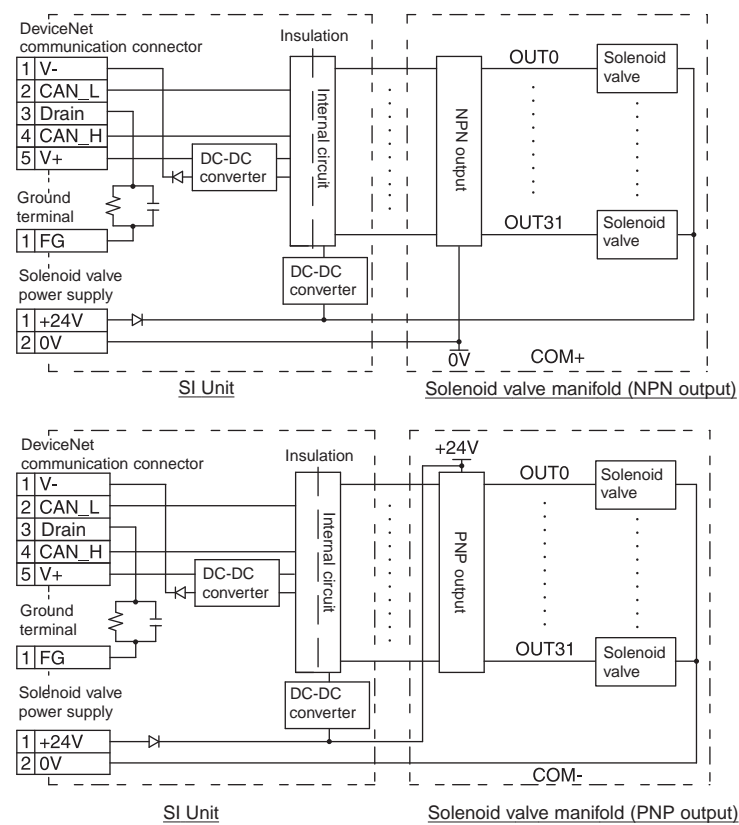

Caution : As EX180-SDN2□ has 16 output points, OUT16 to OUT31 will not be used.

Internal Circuit and Wiring (continue)

Power supply wiring

Connect power supply wiring to the power supply connector (1pcs) which are delivered as accessory of the SI unit. Power supply structure consists of 2 systems, but it can be used with both single power supply and dual power supply. Make sure to connect the designated pin (Refer to Fig.4 and Fig.5).
Tighten properly with 0.22 to 0.25[N•m] of tightening torque.

Note

D type grounding (Third-type grounding) should be performed for FG terminal.

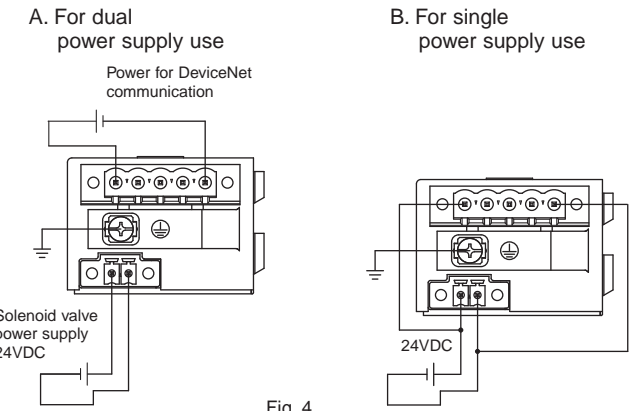

Fig. 4

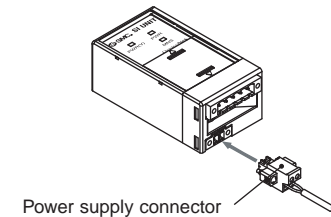

Fig. 5

Communication wiring

The method to connect DeviceNet dedicated cable to the communication connector of SI unit for DeviceNet is shown on the following table.

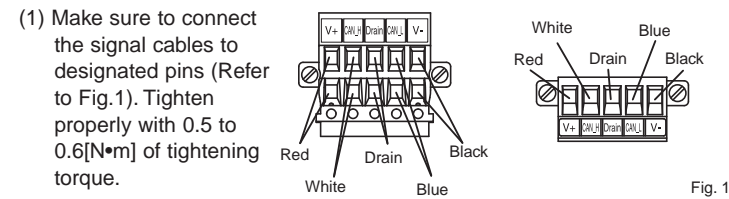

Fig. 1

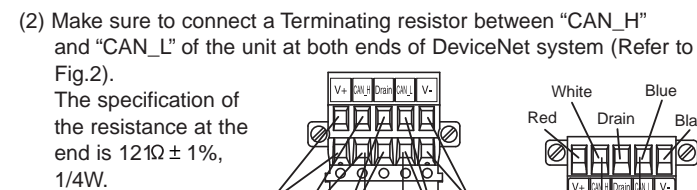

Fig. 2

(3) Refer to Fig.3 about how to connect to the unit.

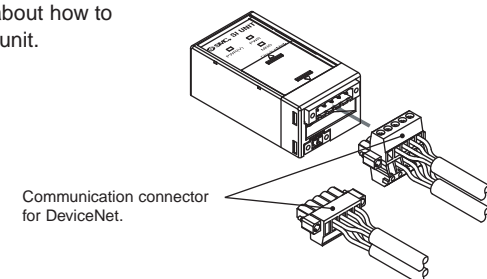

Fig. 3

Contacts

□ When you inquire about the product, please contact to followings.

SMC Corporation

URL <http://www.smcworld.com>

Phone			
AUSTRIA	(43) 2262 62280	NETHERLANDS	(31) 20.531 8888
BELGIUM	(32) 3 355 1464	NORWAY	(47) 67 12 90 20
CZECH REP.	(420) 541 424 611	POLAND	(48) 22 211 9600
DENMARK	(45) 7025 2900	PORTUGAL	(351) 21 471 1880
FINLAND	(358) 207 513513	SLOVAKIA	(421) 2 444 56725
FRANCE	(33) 1 6476 1000	SLOVENIA	(386) 73 885 412
GERMANY	(49) 6103 4020	SPAIN	(34) 945 184 100
GREECE	(30) 210 271 7265	SWEDEN	(46) 8 603 1200
HUNGARY	(36) 23 511 390	SWITZERLAND	(41) 52 396 3131
IRELAND	(353) 1 403 9000	UNITED KINGDOM	(44) 1908 563888
ITALY	(39) 02 92711		

Specifications are subject to change without prior notice and any obligation on the part of the manufacturer.

The descriptions of products shown in this document may be used by the other companies as their trademarks.

© 2006 SMC Corporation All Rights Reserved