



Installation & Maintenance Manual

SI unit - DeviceNet compatible

Type EX140-SDN1



EMC Directive 89/336/EEC

EN61000-6-2:2001 Electromagnetic Compatibility (EMC). Generic standards - Immunity for industrial environments.

EN55011 A1+A2:2001 Limits and methods of measurement of radio disturbance characteristics of industrial, scientific and medical radio-frequency equipment and light industrial environments.

Safety Instructions

This manual contains essential information for the protection of users and others from possible injury and property damage. To ensure correct handling, please follow the instructions.

Please check that you fully understand the meaning of the following messages (signs) before going on to read the text, and always follow the instructions.

Please read the Installation & Maintenance Manual of related apparatus and understand it before operating the unit.

IMPORTANT MESSAGES

Read this manual and follow its instructions. Titles such as WARNING, CAUTION and NOTE will be followed by important safety information which must be carefully followed.

⚠WARNING

Indicates a potentially hazardous situation which could result in death or serious injury if you do not follow instructions.

⚠CAUTION

Indicates a potentially hazardous situation which if not avoided, may result in minor injury or moderate injury.

NOTE

Gives you helpful information.

⚠WARNING

Do not disassemble, modify (including change of printed circuit board) or repair.

An injury or failure can result.

Do not operate beyond specification range.

Fire, malfunction or damage can result.

Only use the unit after confirming the specification.

Do not use the product in the environment with possible presence of flammable, explosive or corrosive gas with the product.

Fire, explosion or corrosion can result. This unit does not have an explosion proof construction.

Safety Instructions (continue)

⚠WARNING

These instructions must be followed when using the product in an interlocking circuit:

- Provide double interlocking by another system such as mechanical protection
 - Check the product regularly to ensure proper operation
- Otherwise a malfunction can cause an accident.

These instructions must be followed while carrying out maintenance work:

- Turn off the power supply
- Stop the supplied air, exhaust the residual pressure and verify the release of air before performing maintenance

Otherwise it can cause injury.

⚠CAUTION

Perform a proper functional check after completing maintenance check.

Please do not operate if there is any abnormality or error.

There is a possibility that safety cannot be assured due to the unexpected malfunction.

Provide grounding for correct operation and improved noise resistance of the unit.

The unit should be individually grounded with a short cable.

NOTE

The direct-current power supply should be a UL approved power supply.

1. Limited voltage current circuit in accordance with UL508.

A circuit which power is supplied by the secondary coil of a transformer that meets the following conditions.

- Maximum voltage (with no load): less than 30Vrms (42.4V peak)
- Maximum current : (1) less than 8A (including when short circuited)
(2) limited by circuit protector (such as fuse) with the following ratings.

No load voltage (V peak)	Max. current rating (A)
0 to 20 [V]	5.0
Above 20 to 30 [V]	100/peak voltage

2. A circuit using max. 30 Vrms(42.4V peak) or less (Class-2 circuit), which power is supplied by Class-2 power supply unit in accordance with UL1310 or Class-2 power supply unit in accordance with UL1585.

Follow the instructions given below when handling the unit. Failure to follow instructions may damage the unit.

- Operate the unit within the specified voltage range.
- Leave space around the unit for maintenance.
- Do not remove labels.
- Do not drop, hit or apply excessive shock to the unit.
- Follow the specified tightening torque.
- Do not bend or apply tensile force to cables, or apply force by placing heavy load on them.
- Connect wires and cables correctly.
- Do not connect wires while the power is on.
- Do not lay wires or cables with power cable or high-voltage cable in the same wiring route.
- Verify the insulation of wiring.

Safety Instructions (continue)

- Take proper measures against noise such as noise filter when the unit is incorporated in equipment or devices.
- Select the proper type of protection according to the environment of operation.
- Take sufficient shielding measures when installing at a following place.
 - (1) A place where noise due to static electricity is generated
 - (2) A place where electric field strength is high
 - (3) A place where there is radioactive irradiation
 - (4) A place near power line
- Do not use the unit close to a place where electric surges are generated.
- Use surge absorber built-in type unit when a surge-generating load such as a solenoid valve is driven directly.
- Prevent foreign matter such as remnant of wires from entering this product.
- Do not expose the unit to vibration and impact.
- Keep the specified ambient temperature range.
- Do not expose the unit to heat radiation from a heat source located nearby.
- Use a precision screwdriver with small flat blade when setting DIP switch.
- Close the cover to DIP switch side during power being supplied.
- Perform maintenance and check regularly.
- Perform a proper functional check.
- Do not clean the product with chemicals such as benzene and thinner.

Specifications

General specifications

Item	Specifications
Operating ambient temp.	0 to +55°C (with 8 points of valve ON) 0 to +50°C (with 16 points of valve ON)
Operating ambient humidity	35 to 85%RH(No dew condensation)
Storage ambient temp.	-20 to +60°C
Vibration proof	50m/s ² (comply with JIS C 0911)
Impact proof	100m/s ² (comply with JIS C 0912)
Noise immunity	Normal mode ±1500 V Pulse 1μs Common mode ±1500 V Pulse 1μs Radiation ±1000 V Pulse 1μs
Withstand voltage	AC1500V for 1 min. between FG and external terminal package.
Insulation resistance	DC500V, 10MΩ between FG and external terminal package.
Operating environment	No corrosive gas and no dust
Weight	80g or less
Protection class	IP20

Specifications (continue)

Electrical and network specifications

Item	Specifications	
Applicable system	DeviceNet Release 2.0	
Power supply voltage for communication	11V DC to 25V DC (supplied by communication connector)	
Power supply voltage for solenoid valve	24V DC +10% / -5%	
Consumption current	Communication and Internal power supply	90mA or less (24V DC)
	Power supply for Solenoid valve	1.5A or less(24V DC)
Solenoid valve Connection spec.	Output style	NPN output (Open collector)
	Connected load	24V DC, Solenoid valve with lamp-surge voltage protection circuit of 2.1W or less. (made by SMC)
	Insulation type	Opt-coupler insulation type
Residual voltage	0.4V DC or less	
Network connection spec.	Applicable DeviceNet	Volume I - Release 1.2 Volume II - Release 1.1
	MAC ID setting range	0 to 63 (Set by DIP switch)
	Baud Rate (Transmission speed)	500kbps, 250kbps, 125kbps (Set by DIP switch)
	Slave (branch station) type	Group 2 only server
	Connection type	T branch type, Multi drop type
	Device type	27
	Product code	1202
	Revision	Referred to EDS file.
	Vendor ID	7
	Corresponding message	Polled command (I/O message), Explicit message

Outline with Dimensions (in mm)

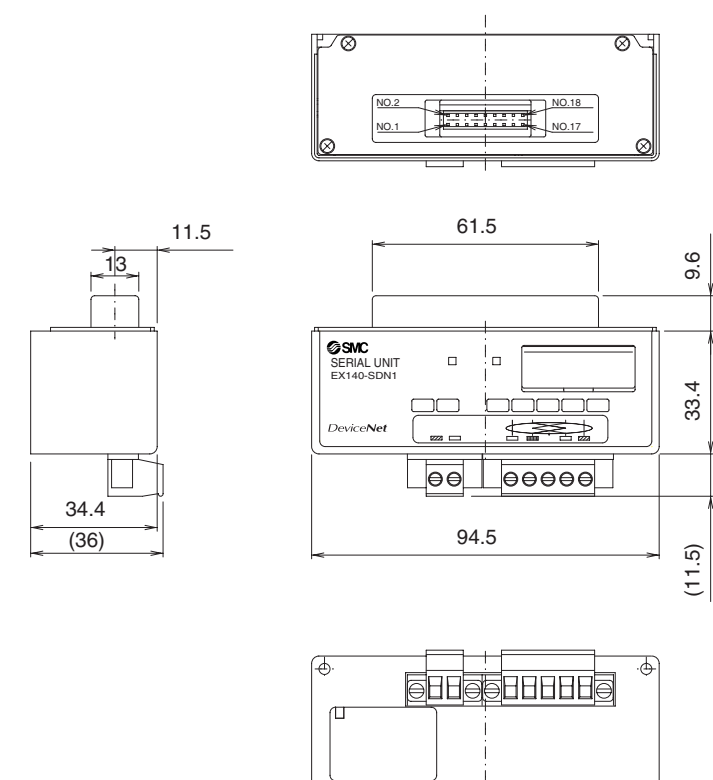

Name of Parts / Accessory

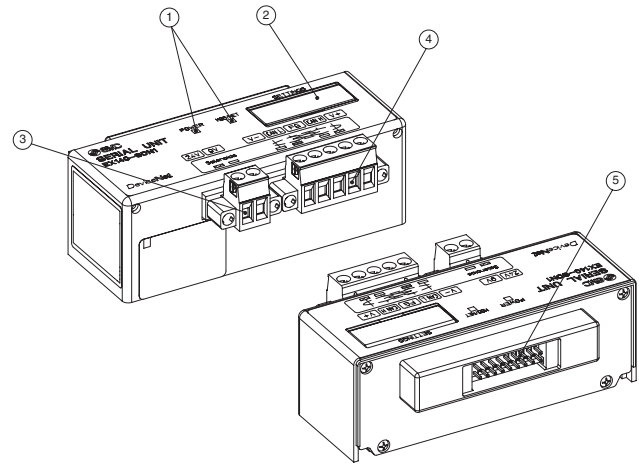

No.	part name	application
1	Indicator LED	The status of the unit is indicated with LED
2	Setting switch area	The node address and communication speed are set
3	Power supply socket	Supply the power
4	Communication socket(BUS)	Connect to DeviceNet line
5	Solenoid valve connection connector	Connect to the solenoid valve

Setting and Display

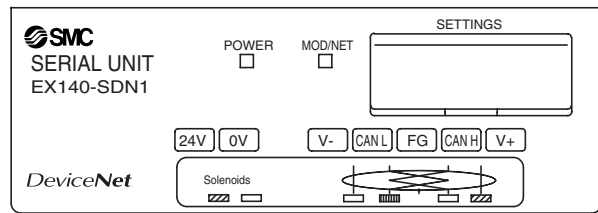

Indication	Contents
POWER	Green Lights up when power for DeviceNet line is supplied.
MOD / NET	Lights off SI unit isn't on line or power supply for communication line isn't turned on.
	Green flashing Waiting for connection (ON line)
	Green lights up Connection completed (ON line)
	Red flashing Connection time out (Minor communication error)
	Red lights up MAC ID duplication error or BUS OFF error (Major communication error)

Installation

Address setting

Before setting the address on DIP switch, turn power supply for SI unit "OFF".

Setting (binary) the following items is available using the DIP switch, which is installed under a cover.

- 1) Node address (00 to 63)
- 2) Communication speed (125kbps, 250kbps, 500kbps)

Setting of node address

Node address	SW1	SW2	SW3	SW4	SW5	SW6
#	1	2	4	8	16	32
#0	0	0	0	0	0	0
#1	1	0	0	0	0	0
#2	0	1	0	0	0	0
⋮						
#62	0	1	1	1	1	1
#63	1	1	1	1	1	1

Setting of communication speed

Setting SW7	SW8	Communication speed (kbps)	Max. transmission distance (m)		
			Length of trunk cable	Length of branch line	Total branch line
0	0	125	500		156
1	0	250	250	100	78
0	1	500	125		39
1	1	Not used	Not used		

Setting of output when communication stops

SW9	Output condition of solenoid valve when communication stops (Time-out error of I/O connection) or Fault message is received. (Initial condition of solenoid valve)
1	HOLD All outputs are held. (Fault action = 1, Fault value = 0)
0	CLEAR All outputs are cleared. (Fault state = 0, Fault value = 0)

Setting of mode

Mode	Setting
0	HW mode Setting of address and speed is done by SW.1 to 8.
1	SW mode Setting of address and speed is done via network. *SW.1 to 8 isn't available.

Wiring

Wiring of cable for solenoid valve power supply and communication

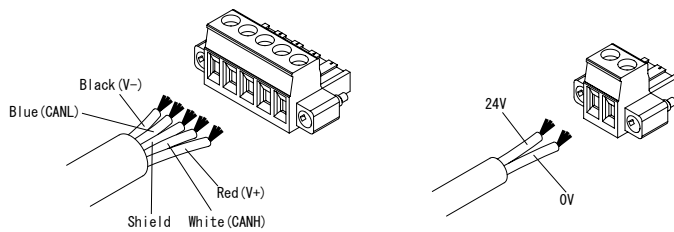

Communication connection for DeviceNet

Terminal	Wire color	Connected to
V-	Black	(-) side of power supply cable
CANL	Blue	Low side of communication cable
FG	-	Ground / Shield
CANH	White	High side of communication cable
V+	Red	(+) side of power supply cable

Power supply connector for solenoid valve

Terminal	Wire color	Connected to
24V	-	(+) side of solenoid valve source supply
0V	-	(-) side of solenoid valve source supply

NOTE

- Before wiring, be sure to turn power supply off.
- Screw for connectors is M3. Tighten them properly by torque of 0.5 to 0.6 [N•m].
- SI unit isn't available for monitoring of power supply for solenoid valve.
- Do not put cable specified by DeviceNet with/near high voltage line or strong electric line such as driving line.

☐ To enquire about the product, please contact the following.

SMC Corporation

URL <http://www.smcworld.com>

Phone	ITALY / (39) 02-92711
AUSTRIA / (43) 2262-62 280	NETHERLANDS / (31) 20-531 8888
BELGIUM / (32) 3-355 1464	NORWAY / (47) 67 12 90 20
CZECH REP. / (420) 5-414 24611	POLAND / (48) 22-548 50 85
DENMARK / (45) 70 25 29 00	PORTUGAL / (351) 2 610 89 22
FINLAND / (358) 9-859 580	SPAIN / (34) 945-18 4100
FRANCE / (33) 1-64 76 1000	SWEDEN / (46) 8-603 0700
GERMANY / (49) 6103 4020	SWITZERLAND / (41) 52-396 3131
GREECE / (30) 1- 342 6076	TURKEY / (90) 212 221 1512
HUNGARY / (36) 1-371 1343	UNITED KINGDOM / (44) 1908-56 3888
IRELAND / (353) 1-403 9000	