



Installation & Maintenance Manual

SI Unit-ProfiBusDP compatible

Type 56-EX250-SPR1-X42

CE II 3GDEEXnA II T4X+5°C ≤ Ta ≤ +45°C IP67

Read this manual before using this product.

For future reference, please keep this manual in a safe place.

This manual should be read in conjunction with the current catalogue.

Safety Instructions

General recommendation

These safety instructions are intended to prevent a hazardous situation and/or equipment damage.

These instructions indicate the level of potential hazard by label of "Caution", "Warning" or "Danger".

Caution : Operator error could result in injury or equipment damage.

Warning : Operator error could result in serious injury or loss of life.

Danger : In extreme conditions, there is a possible result of serious injury or loss of life.

WARNING

A system designer or a person who decides a system specification should judge the compatibility of the product. Since the products specified here are used in various operating conditions, their compatibility for the specific must be based on specifications or after analysis and/or tests to meet your specific requirements.

Only trained personnel should operate pneumatically operated machinery and equipment.

Compressed air can be dangerous if an operator is unfamiliar with it. Assembly, handling or repair of the product should be performed by trained and experienced operators.

Do not service machinery/equipment or attempt to remove component until safety is confirmed.

1) Inspection and maintenance of machinery/equipment should only be performed after confirmation of safe locked-out control positions.

2) When equipment is to be removed, confirm the safety process as mentioned above. Switch off air and electrical supplies.

3) Before machinery/equipment is re-started, ensure all safety measures to prevent sudden movement of actuators etc. (Supply air into the system gradually to create backpressure, i.e. incorporate a soft-start valve).

Contact SMC if the product is to be used in any of the following conditions:

1) Conditions and environments beyond the given specifications, or if product is used outdoors.

2) Installations in conjunction with atomic energy, medical equipment, food and beverage, or safety equipment.

3) Applications which have the possibility of having negative effects on people, property or animals. Special safety analysis is required.

Safety Instructions (continue)

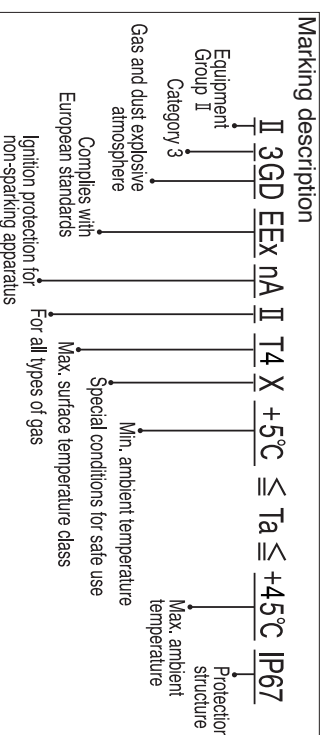

Conformity to standard

This product is certified to and complies with the following standards:

ATEX Directive 94/9/EC

EN 50014:1998 Electrical apparatus for potentially explosive atmospheres - general requirements

EN 50021:1999 Electrical apparatus for potentially explosive atmospheres - Type of protection "n"

EN 50281-1-1:1999 Electrical apparatus protected by enclosures - construction and testing.

EMC Directive 89/336/EEC

EN 61000-6-2:2001 Electromagnetic Compatibility (EMC). Generic standards-Immunity for industrial environments.

EN 55011:1998/A1:1999 Limits and methods of measurement of radio disturbance characteristics of industrial, scientific and medical (ISM) radio-frequency equipment and light-industrial environments.

WARNING

Design and selection

1) Operate the unit only within the specified supply voltage limits. If the supply voltage exceeds the rated voltage the unit and connected equipment might malfunction or could be damaged. It could also become a fire hazard.

2) Do not operate beyond specification range. Fire, malfunction or unit and connected equipment damage can result.

3) Please construct a backup system, such as making the equipment or unit a multiple system, or designing a fail-safe in advance to prevent damage due to the breakdown and the malfunction of this product.

4) Mount the emergency stop outside of the enclosure so that it can stop the system operation immediately and intercept the power supply.

5) These instructions must be followed when using the SI unit in an interlocking circuit:

•Provide valve interlocking by another system such as mechanical protection.

•Check the SI unit regularly to ensure mechanical protection.

There is a risk of getting injured if the interlock does not operate correctly.

Wiring

1) Perform wiring correctly.

There is a possibility that a unit and connected equipment will be destroyed if incorrectly wired.

2) Do not perform wiring while power is on. If there is an explosive atmosphere present there is a risk of an explosion. There is also a possibility of failure of operation due to the damage of a unit and connected equipment.

3) Do not lay wires or cables with power cable or high-voltage cable in the same wiring route. There is a possibility of failure of operation due to electrical noise on the signal cable or a surge in the power cable. Separate the wiring of reduced wiring system from power cables.

4) Confirm proper insulation of wiring.

With insulation failure (contact with other circuits, insulation failure between terminals, etc), there is a risk of explosion if an atmosphere is present. There is also a possibility of damage to a unit and connected equipment due to the applied excess pressure or current.

Operating environment

1) Do not use in an environment where water, chemicals, or oil are present. Prevent dust and particles collecting on or around the unit.

It will cause failure or malfunction.

2) Do not use in an area where a magnetic field is generated. It will cause malfunction.

WARNING

3) Do not connect or disconnect cables when the unit is powered. Fire or an explosion may result if an explosive or combustible gas is present.

4) Do not use in an environment with temperature cycle. Heat cycles other than that of daily change of the temperature can effect inside of the units.

5) Do not expose the wiring system to heat radiation from a heat source located nearby.

It will cause failure or malfunction.

6) Do not use in an environment where a surge source more than the CE marking standard allow is present.

Internal circuit elements can deteriorate or break when equipment generating a large surge (electromagnetic lifter, high frequency induction furnace, motor, etc.) is located near the wiring system. Provide surge preventives, and avoid interface.

7) Use the wiring system equipment with surge absorber when a surge-generating load such as relay or solenoid valve is driven directly.

8) Do not expose the wiring system to vibration and impact. It will cause failure or malfunction.

Adjustment and Operation

1) Do not open the case or adjust settings while energised. Fire or an explosion may result if an explosive or combustible gas is present.

2) Do not allow short circuit of loads.

Connected equipment may be damaged by excess current flow if a load is short circuit. Input unit fuse will break. Output and SI unit have protective function for excess current flow, but it is possible that they will be damaged, as the protective function does not cover all modes.

3) Do not carry out operation or setting of this equipment with wet hands.

It may cause an electric shock to the operator.

Maintenance

1) Do not disassemble, modify (including change of printed circuit board) or repair.

An injury or failure can result.

2) Perform the following maintenance periodically in order to prevent possible danger due to the unexpected.

Confirm wiring and screws are not loose. Loose screws or wires may cause unintentional malfunction.

3) These instructions must be followed while in maintenance:

•Turn off the power supply.

•Stop the supplied fluid, exhaust the residual pressure and verify the release of fluid before performing maintenance.

Otherwise it can cause injury.

CAUTION

Design and selection

1) Ensure there is sufficient clearance for maintenance activities.

When designing an application, be sure to allow sufficient clearance for maintenance and inspections.

2) Use a direct current power supply with the following specifications to power the unit. The power supply should have UL authorization.

1) Limited voltage current circuit in accordance with UL508

A circuit which power is supplied by the secondary coil of a transformer that meets the following conditions

•Maximum voltage (with no load) : less than 30Vrms (42.2V peak)

•Maximum current : (1) less than 8A (including when short circuited) (2) limited by circuit protector (such as fuse) with the following ratings.

No load voltage (V peak)	Max. Current rating (A)
0 to 20 [V]	5.0
above 20 to 30 [V]	100 / peak voltage

2) A circuit using max. 30Vrms or less (Class-2 circuit), which power is supplied by Class-2 power supply unit in accordance with UL1310 or Class-2 power supply unit in accordance with UL1585

3) This product is a component which is to be built into a piece of completed equipment. The compatibility with the EMC directive after the product is installed, should be checked by you.

Mounting

1) Do not drop, bump or apply excessive impacts while handling. Otherwise it can result in damage to the product causing failure or malfunction.

2) Hold the body for handling.

Otherwise it can result in damage to the product causing failure or malfunction.

CAUTION

3) Mount units using the proper tightening torque.

If a unit is tightened beyond the range of tightening torque, the mounting screws, mounting brackets or unit may be damaged.

4) Do not mount the unit where it may be stepped on. If the unit is stepped on it will be damaged.

Wiring

1) Avoid repeatedly bending or stretching the lead wires.

Do not crush or strain the wire. It will cause the wire to break and make the unit malfunction.

2) Ground the SI unit to a secure, safe and noise-proof place. Grounding should be performed near the unit to shorten the grounding distance.

Adjustment and Operation

1) Set DIP switch and rotary switch with a thin clock driver etc.

Maintenance

1) Only clean the product with a damp cloth.

Do not wipe the product with chemicals such as benzene or thinners. It will cause damage to the product.

Model Indication Method

56-EX250-SPR1-X42

ATEX Category 3

Intended conditions of use

The SI unit should be used within the range of specifications below and the SI unit catalogue.

If labelled with X: special conditions applied:

1. Protect the SI unit against all impact or mechanical damage.

2. The unit should not be exposed to prolonged sunlight that can generate surface temperature higher than the value given for temperature class. Use a protective cover.

3. If foreign particles (E.g. iron dust, weld spatter) are allowed to accumulate around the unit, it could reduce the magnetic field strength, and may effect the detection signal. Clean away these particles.

Specification

General specification

Item	Specification
Operating ambient temp.	+5 to +45 °C
Operating ambient humidity	35 to 85% RH (No dew condensation)
Storage ambient temp.	-20 to +60 °C
Vibration proof	10 to 57Hz 0.35mm (Constant amplitude) 57 to 150Hz 50m/s ² (Constant acceleration)
Impact proof	150m/s ² (peak), 11ms × three times in each direction ± X, Y and Z.
Noise immunity	Normal mode : ±1500V Pulse duration 1us Common mode : ±1500V Pulse duration 1us Radiation : ±1000V Pulse duration 1us
Withstand voltage	500V AC for 1min.
Insulation resistance	500V DC, min10M ohm
Operating environment	No corrosive gas and no dust

Electrical and network

Item	Specification
Power voltage range	Power for SI/Input Block Max. 1.1A or less
	Current consumption Block stations and sensor specifications.
Current consumption	Power for solenoid valve Max 2.0A or less
	Current onsumption Depending on the number of solenoid valve stations and specifications.
Solenoid valve connection spec.	Output type P-chn MOS-FET Open drain type
	Connection load Solenoid valve with protection circuit for 24V DC and 1.5W or less surge voltage. (made by SMC)
	Insulation type Opto coupler type
	Residual voltage 0.3V DC or less

Communication specification

Item	Specification
Protocol	PROFIBUS-DP(EN50170,EN50254)
BUS interface	EIA RS485
Communication from	Token passing
Transmission rate	9.6, 19.2, 93.75, 187.5, 500, 1500, 12000(kbps)
Transmission media	STP cable
Connect node	Max. 125 station
Network topology	Bus, tree, star
Cable length	Max. 23km (Repeater needed)
Freeze mode	Available
Sync mode	Available
Input point	Max. 32 points
Output point	Max. 32 points
ID number	1408hex(SW setting mode) 1409hex(HW setting mode)

Names and Functions of individual parts

Body

- Communication connector
- To send and receive communication signals through PROFIBUS-DP line.
- Power supply connector for output equipment, SI unit and Input block valve, and output block, SI unit and Input block.
- Output equipment connector
- To connect the output equipment such as a solenoid valve and output block.
- Input block connector
- To connect the Input block.
- Indication and address setting panel
- To provide LED's to indicate the condition of the unit, and the setting of the address mode.
- Ground terminal
- To be connected to the ground.

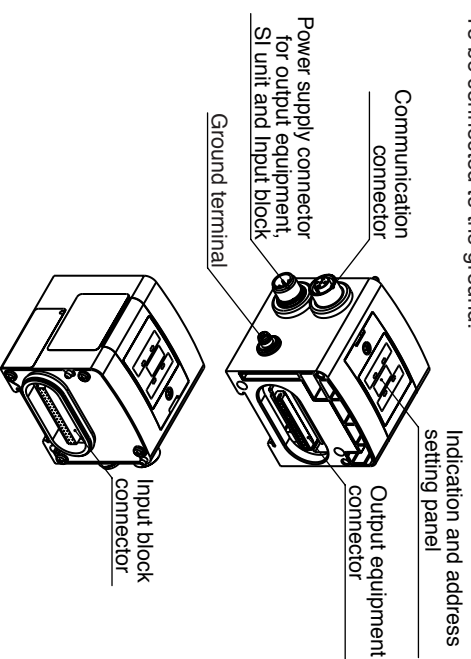

Display

LED Indication

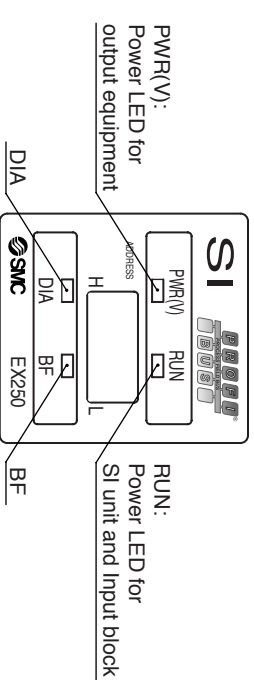

Indication	Contents
PWR (V)	Green Light ON when power for solenoid valves is supplied. Light OFF when supply voltage decreases below 19V
RUN	Green Light ON during normal operation (when power for SI unit is supplied)
DIA	Red Light ON when a failure is detected by self-diagnosis
BF	Red Light ON when a bus failure is detected

Installation

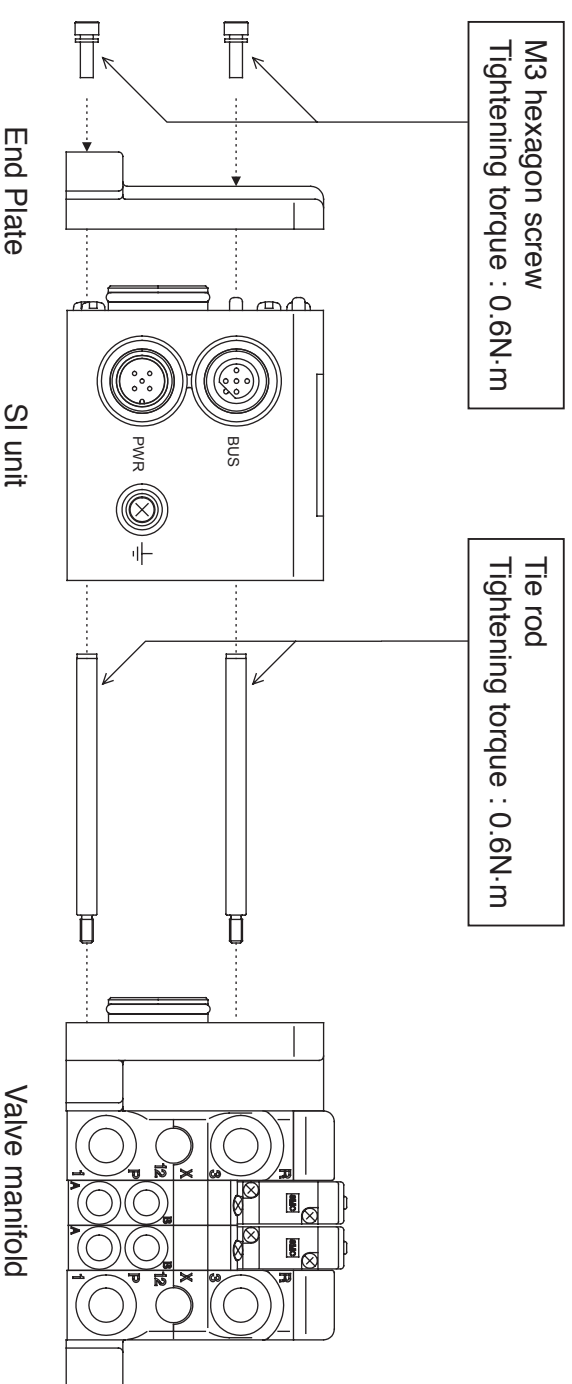

Outline with Dimensions (in mm)

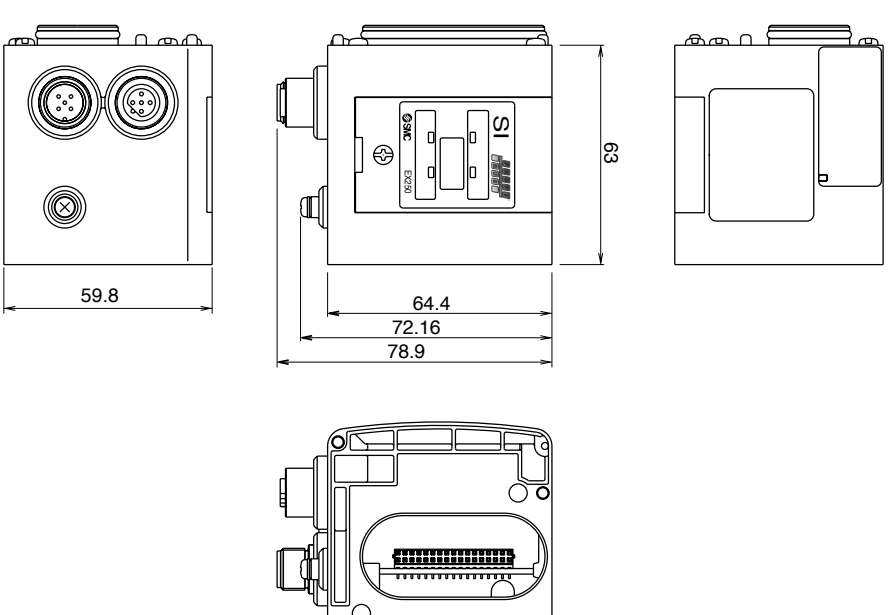

- To enquire about the product, please contact the following :

SMC Corporation

URL <http://www.smcworld.com>

Phone

AUSTRIA / (43) 2262-62 280	ITALY / (39) 02-92711
BELGIUM / (32) 3-355 1464	NETHERLANDS / (31) 20-531 8888
CZECH REP. / (420) 5-414 24611	NORWAY / (47) 67 12 90 20
DENMARK / (45) 70 25 29 00	POLAND / (48) 22-548 50 85
FINLAND / (358) 9-859 580	PORTUGAL / (351) 2 610 89 22
FRANCE / (33) 1-64 76 1000	SPAIN / (34) 945-18 4100
GERMANY / (49) 6103 4020	SWEDEN / (46) 8-603 0700
GREECE / (30) 1-342 6076	SWITZERLAND / (41) 52-396 3131
HUNGARY / (36) 1-371 1343	TURKEY / (90) 212 221 1512
IRELAND / (353) 1-403 9000	UNITED KINGDOM / (44) 1908-56 3888