



Installation and Maintenance Manual

Series 52-IP8101 Smart Positioner (Rotary type)

II 1G EEx ia IIC T4 -20°C ≤ Ta ≤ 80°C
II 1D T83°C -20°C ≤ Ta ≤ 80°C IP65

Read this manual before using this product

- The information within this document is to be used by pneumatically trained personnel only.
- For future reference, please keep manual in a safe place.
- This manual should be read in conjunction with the current catalogue.

ATEX marking description

II 1G EEx ia IIC T4 -20°C ≤ Ta ≤ 80°C
II 1D T83°C -20°C ≤ Ta ≤ 80°C IP65

Group II Category 1 G and D - Suitable for Gas and Dust environment
EEx ia - Intrinsic Safety IIC - Explosion Group T4 - Temperature classification
Ta - Ambient Temperature range T83°C - Max. Surface Temperature

1 SAFETY RECOMMENDATION

1.1 General recommendation

These safety instructions are intended to prevent a hazardous situation and/or equipment damage. These instructions indicate the level of potential hazard by label of "Caution", "Warning" or "Danger". To ensure safety, be sure to observe ISO4414 (Note1), JIS B 8370 (Note2) and other safety practices.

Note 1: ISO 4414: Pneumatic fluid power - General rules relating to systems.

Note 2: JIS B 8370: Pneumatic system axiom.

CAUTION: Operator error could result in injury or equipment damage.

WARNING: Operator error could result in serious injury or loss of life.

DANGER: In extreme conditions, there is a possible result of serious injury or loss of life.

WARNING:

- The compatibility of pneumatic equipment is the responsibility of a person who designs the pneumatic system or decides its specification.**
 - Since the products specified here are used in various operating conditions, their compatibility for the specific pneumatic system must be based on specifications or after analysis and/or tests to meet your specific requirements.
- Only trained personnel should operate pneumatically operated machinery and equipment.**
 - Compressed air can be dangerous if an operator is unfamiliar with it. Assembly, handling or repair of pneumatic systems should be performed by trained and experienced operators.
- Do not service machinery/equipment or attempt to remove components until safety is confirmed.**
 - Inspection and maintenance of machinery/equipment should only be performed after confirmation of safe of dangerous fluid.
 - When equipment is to be removed, confirm the safety process as mentioned above. Switch off air and electrical supplies and exhaust all residual compressed air in the system.
 - Before machinery/ equipment is re-started, ensure all safety measures to prevent sudden movement of cylinders etc. (Bleed air into the system gradually to create backpressure, i.e. incorporate a soft-start valve).
- Contact SMC if the product is to be used in any of the following conditions:**
 - Conditions and environments beyond the given specifications, or if product is used outdoors.
 - Installation on equipment in conjunction with atomic energy, railway, air navigation, vehicles, medical equipment, food and beverages, recreation equipment, emergency stop circuits, press applications, or safety equipment.
 - An application, which has the possibility of having negative effects on people, property, or animals, requiring special safety analysis.

CAUTION:

- Ensure that the air supply system is filtered to 0.3 micron.

1.2 Specific recommendations

- If the input current is disconnected during use, the output of OUT1 will become OMPa and the output of OUT2 will reach its maximum, regardless of the operating direction of the parameter mode (parameter code: 200), whether direct or in reverse.
- If reverse operation is selected in parameter mode (parameter code: 200), when the power supply is turned off, OUT1 output will become OMPa and the positioner will start moving toward input current 20mADC direction.
- Depending on the parameter's setting, the actuator will move erratically when an input current of 4mA DC is applied.
- There is a capacitor for noise prevention between FG terminal (case) and each input / output terminal of the positioner respectively. Therefore, avoid conducting withstand voltage testing or insulation resistance testing between the terminal and case.
- Please refer to the Operation manual for further details.

2 INTENDED CONDITIONS OF USE

2.1 Specifications

Protect the unit from impact and dropping during installation and when mounted. This may cause failure of the unit.

- Do not use the unit in places with high humidity & temperature. This may cause malfunctions.
- Do not use this positioner outside of the range of it's specifications as this can cause failure.

Table1 Specifications

Item	Model
	52-IP8101-0**-*-*
Input current	4~20mADC *1 (2 wire system, Separate power source unnecessary)
Minimum current	3.85mADC or more
Voltage between terminals	12VDC (Input resistance equivalent to 600Ω, at 20mADC)
Max supply power	1W *2 (100mADC, 28VDC)
Supply air pressure	0.3~0.7MPa
Standard stroke	60°~100°*3
Sensitivity	±0.2%F.S. or less *4
Linearity	±1%F.S. or less *4
Hysteresis	0.5%F.S. or less
Repeatability	±0.5%F.S. or less
Temperature coefficient	0.05%F.S./°C or less
Max output flow rate	200 l/min(ANR) or more (SUP=0.4MPa) *5
Air consumption	11 l/min(ANR) or less (SUP=0.4MPa) *5
Ambient and Operating fluid temperature	-20°C~80°C
Explosion protected construction	ATEX Intrinsic safety type of explosion protected construction <div style="border: 1px solid black; padding: 5px; display: inline-block;"> (CE 0344 Ex II 1G EEx ia IIC T4 Ta80°C) </div> <div style="border: 1px solid black; padding: 5px; display: inline-block;"> CE 0344 Ex II 1D T83°C Ta80°C </div> Approval No. Nemko 05ATEX1202X
Intrinsically Safe Parameters	Ui=28V, Ii=100mA, Pi=0.7W, Ci=12.5nF, Li=1.5mH
Classification of degree of Protection	JISF8007 IP65 (Conform to IEC Pub.60529)
Communication Protocol	HART communication
Air connection ports	Rc1/4 female thread (or G1/4 or 1/4NPT)
Electrical connections	M20×1.5 female thread (or G1/2 or 1/2NPT)
Material	Body/Cover : Die cast aluminium (Coating : Epoxy resin baked) Shaft / Screw : Stainless
Weight	Approx 2.6kg

Table2 Specifications of options

Item	Model
	52-IP8101-0**-*-*
Alarm output1, 2 *6	
Corresponding standard	DIN19234 / NAMUR Standard
Wiring method	2 wire system
Power supply voltage	5~28VDC
Output current	ON : 2.1mADC or more OFF : 1.2mADC or less
Analogue output *7	
Wiring method	2 wire system
Supply source voltage	10~28V DC
Output current	4~20mADC (Min.:3.85mADC / Max.: 24mADC)
Load resistance	0~750Ω
Accuracy	±0.5%F.S. or less *8

*1: 1/2 split range is available using the split range setting (parameter code: 300).

*2: <Ex.> When applying an input current of 80mA DC, an input power supply voltage of 12.5V DC or less will prevent damage to the positioner.

$$\text{Max. supply power} = 80\text{mA DC} \times 12.5\text{V} = 1\text{W}$$

*3: If the actuator rotating angle is 100° or less, its stroke can be adjusted optionally in a range from 0 to 60° and from 0 to 100°.

*4: Linearity is a characteristic checked without loads using a factory inspection machine. The positioner can not work independently and is used as a part of loop including actuating equipment such as a valve, actuator and DCS. Therefore, it should be noted that the described characteristic values may vary depending on the loop conditions.

*5: (ANR) indicates standard air in accordance with JIS B0120.

*6: When no input current has been applied, an alarm is output. Fig. 1 shows an internal alarm circuit.

*7: Connect a load resistance with consideration given to the minimum power supply voltage.

*8: Analogue output accuracy to position value (P value) in the LCD display.

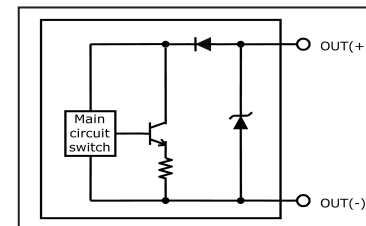
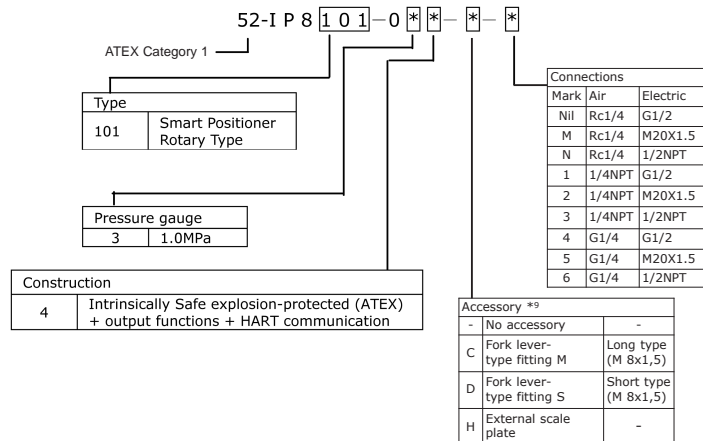

Fig. 1

2.2 How to Order



*9: If two or more accessories are required, the part numbers should be made according to alphabetical order.

3 INSTALLATION

WARNING:

- Do not install unless the safety instructions have been read and understood.
- Avoid hitting the product with metallic objects.
- Avoid using this product in non-explosive environments which can become explosive due to air leakage.
- If the system is in possible danger because of failure of the positioner, prepare the system with an alternative safety circuit to avoid danger.
- When using this product in hazardous areas, ensure that the operational speed of the moving parts is less than 1m/s, and that the actuator is not hunting.
- Impact and friction hazards must be considered according to EN 50284 clause 4.3.1 when the positioner has an aluminium enclosure.

3.1 Environment

WARNING:

- Do not use in an environment where the product is exposed to corrosive gas, chemicals, salt water, water or steam.
- Do not use in a location where there is danger of explosion.
- Do not mount the product in a location where it is subject to strong vibrations and/or shock. When the positioner is used in places subject to vibrations, it is recommended that a suitable cable support be used to prevent the lead wires from breaking.
- Do not mount the product near the source of electrical noise.
- Do not mount the product in a location where it is exposed to radiant heat.
- Allow sufficient space for maintenance and adjustment around the product when mounted.
- The product should not be exposed to prolonged sunlight that can generate a surface temperature higher than the value given for the temperature classification. Use a protective cover.

3.2 Piping

CAUTION:

- Before piping make sure to clean up chips, cutting oil, dust etc.
- When installing piping or fitting into a port, ensure that sealant material does not enter inside the port. When using seal tape, leave 1.5 to 2 threads exposed on the end of pipe / fitting.
- Use de-humidified and dust-removed clean air as the supplied air source.
- The Positioner has very fine internal paths. Therefore please use clean air which is dehydrated and filtered, and also avoid using lubricant. In addition, use a cleaning system according to No. 4 or higher from the "Compressed Air Cleaning Equipment" listed in the manual for the air-supply cleaning systems.
- Avoid using compressed air containing chemicals, synthetic fluid including organic solvent, salinity, and corrosive gas as it may cause malfunction.

3.3 Electrical connection

CAUTION:

- Be sure to perform electrical wiring with the input current turned off.
- Be sure to use a grounding to prevent noise from interrupting input current and static electricity from damaging the positioner.
- Do not touch around the actuator axis when applying an input current after electrical wiring.
- Use an input current source (4 to 20mA DC) with a secure 12V DC or greater voltage as close as possible to the input current terminal to avoid voltage drops.
- Safety Barriers used in the Positioner supply circuit must be linear resistive output type barriers, in accordance with the I.S. Parameters given in the specifications (Table 1).
- Explosion proof cable gland supplied for M20x1.5 electrical connections (code M) is approved to ATEX II 2GD, but subsequently tested by the notified body in accordance with ATEX II 1GD during certification of the 52-IP8101 Positioner.

3.4 Mounting

WARNING:

- Confirm the positioner is securely and firmly mounted onto the actuator.
- Be careful not to get fingers caught when matching mounting positions.

CAUTION:

- Be sure to keep the necessary space available for maintenance work (piping, wiring, adjustment, etc.) in your setup location.
- Disconnect the supply pressure and ensure compressed air is discharged from the positioner and actuator completely before starting mounting.

3.5 Lubrication

CAUTION:

- The positioner has a fixed orifice and nozzle, which contain fine internal paths. Use filtered, dehydrated air and avoid the use of lubricants as this may cause malfunction of the positioner. Ensure that the air supply system is filtered to 0.3 micron.

3.6 Handling

CAUTION:

- Avoid applying impact to the body and torque motor of the positioner, and avoid excessive force to the armature because it may lead to failure. Handle with care during transportation and operation.
- If the positioner is left unused at the operation site for an extended period, ensure the body cover unit is fitted, and mount a plug on the wiring and piping ports. If the atmosphere is of high temperature or high humidity, take measures to avoid condensation inside the positioner. The condensation control measures must be taken thoroughly during export shipment.
- Be sure to mount the body cover unit when using the positioner. IP 65 cannot be guaranteed if the mounting condition of the body cover is incorrect. To achieve IP capability, tighten the screws with the appropriate torque (2.8 to 3.0Nm).
- When the External scale plate (option H) is selected, the scale plate indicator moves with the actuator. Take care to keep hands clear during actuator operation.

4 WORKFLOW OF IP8101 POSITIONER SETUP

The workflow of IP8101 smart positioner from set-up to initial adjustment is shown below. Follow this flow when performing set-ups and adjustments of the positioner. Please refer to the manual for details.

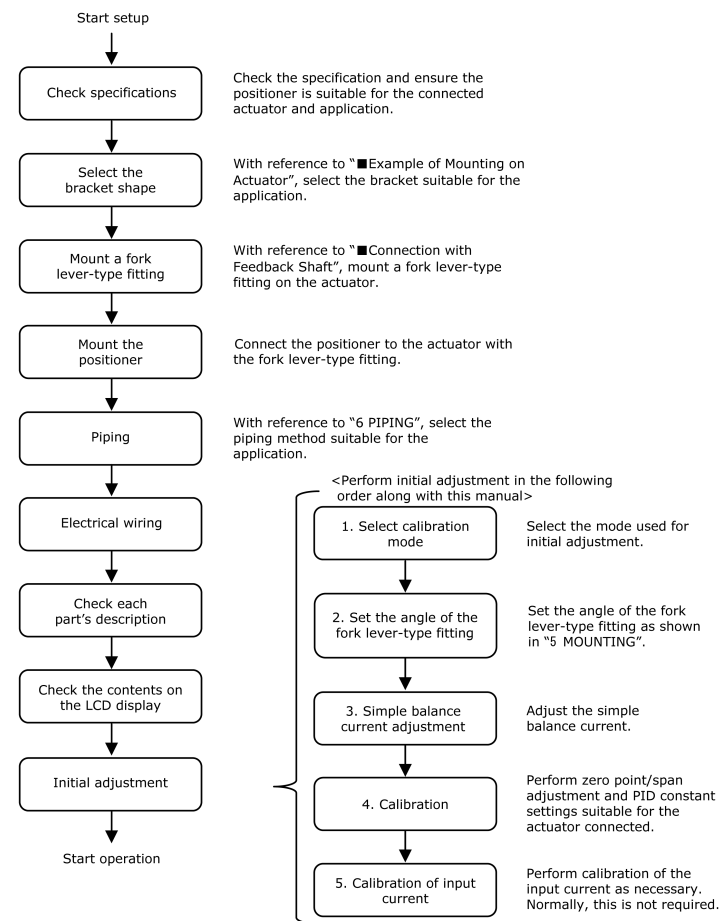

Fig. 2

5 MOUNTING

Example of Mounting on Actuator

The IP8101 Smart Positioner offers interchangeability in mounting pitch with the IP610, IP6100 and IP8100 Positioners. Therefore, it is possible to apply a bracket for IP610, IP6100 and IP8100 for mounting. However, if an IP6100 is replaced with this positioner and accessory H (with an external scale plate) is selected, it will be necessary to lower the position of the fork lever-type fitting.

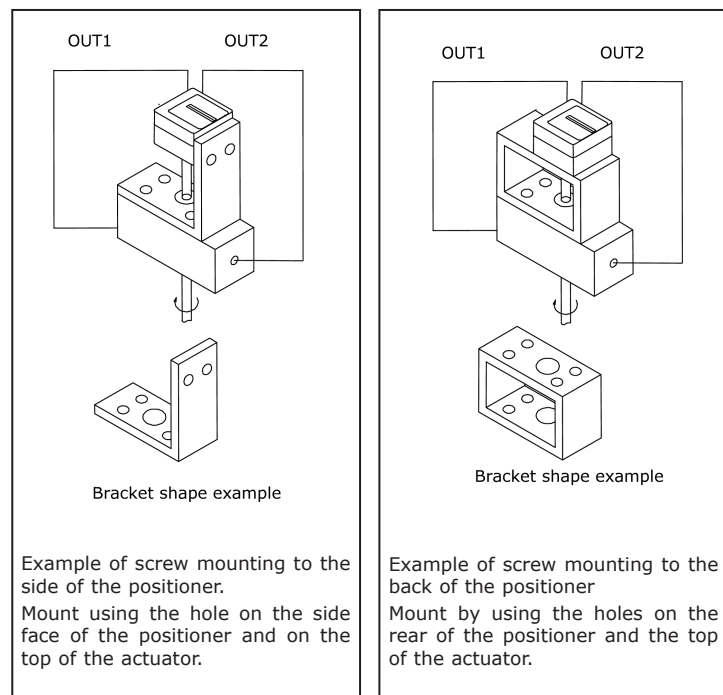

Fig. 3

Fig. 4

Connection with Feedback Shaft

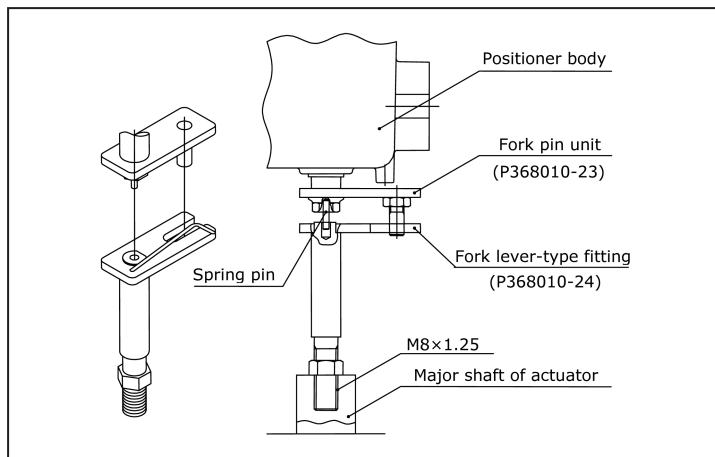

Fig. 5

- Screw in a fork lever-type fitting to the major shaft of actuator and adjust its height to avoid interference with the fork pin unit.
- Adjust the angle of the fork lever-type fitting to avoid interference with the positioner body while the actuator is fully opening from a fully-closed condition.
- Mount so that the feedback shaft of the positioner and major shaft of actuator are almost aligned (where the spring pin at the end of the feedback shaft engages with a hole at the end of the fork lever-type fitting axis).

Fork lever-Type Fitting

Description	Part no.
Fork lever-type fitting M	P368010-24
Fork lever-type fitting S	P368010-25

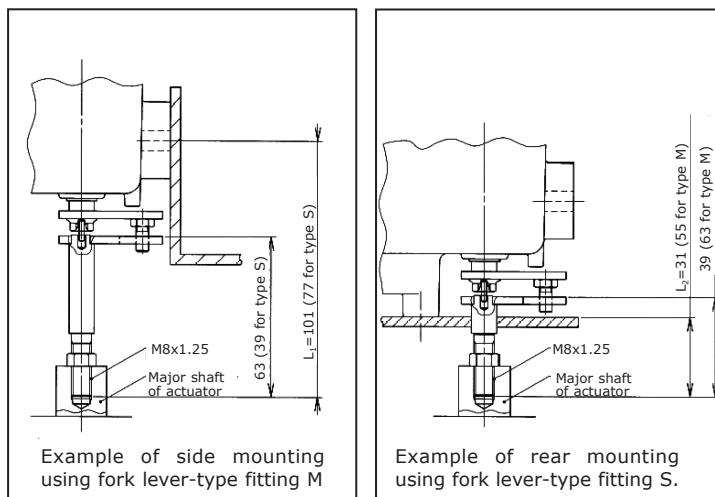

Fig. 6

Fig. 7

6 PIPING

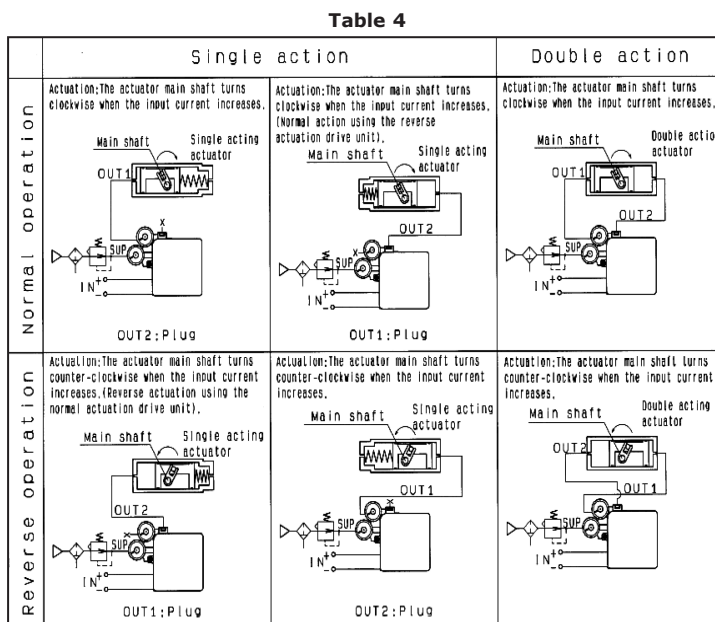

Table 4

7 ELECTRICAL WIRING

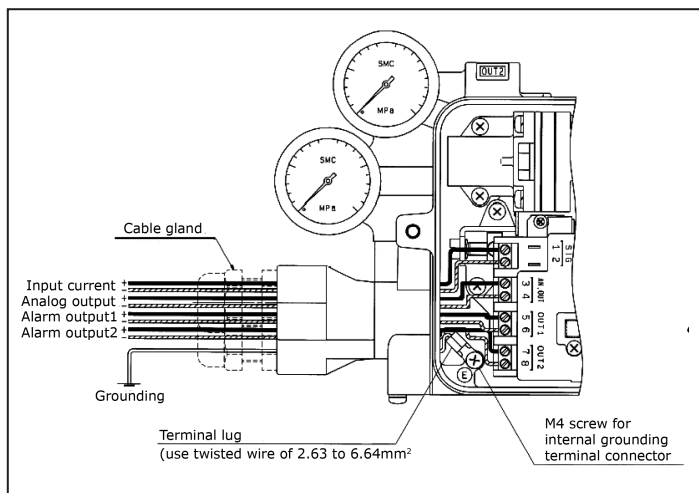

Fig. 8

- Remove the positioner body cover.
- Connect the input current wiring from an adjusting meter (controller) and connect each output wiring following Fig. 8. The input port of the electrical connection is equipped with a (blue) cable connector M20x1.5.

Note: When the electrical connections are G1/2 or 1/2NPT option, the cable glands will not be provided.

WARNING:

To use in an explosion protection specification the positioner may only be connected to a certified intrinsically safe electrical circuit with the following maximum values.

Parameters (current circuit)
 $U_i=28V$, $I_i=100mA$, $P_i=0.7W$, $C_i=12.5nF$, $L_i=1.5mH$

8 DESCRIPTION OF COMPONENTS

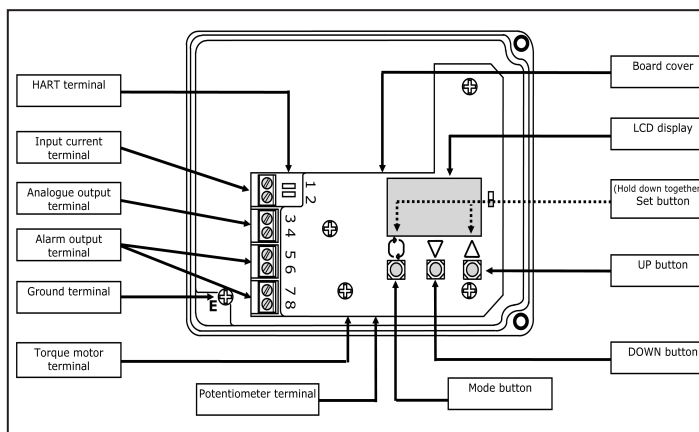

Fig. 9

9 MAINTENANCE

WARNING:

- Do not dis-assemble the product. A product which has been dis-assembled cannot be guaranteed. Consult with SMC if dis-assembly is necessary.
- After installation, repair and dis-assembly, connect compressed air and perform a proper functional test and leak test. If bleed noise is louder than the initial state or operation is abnormal, stop operation and check if installation is correct or not.
- Modification of the electrical construction is prohibited to maintain explosion proof certification.

CAUTION:

- Check if supply air is clean. Inspect compressed air cleaning system periodically so that dust, oil and humidity, which can cause malfunction and failure of the unit, do not enter the equipment.
- If handled improperly, compressed air can be dangerous. Maintenance and replacement of unit parts should only be performed by trained and experienced personnel for instrumentation equipment, as well as following the product specifications.

- Check the positioner once a year. If excessively worn diaphragms, O-rings or seals are found, or any unit that has been damaged, replace with new units. Treatment at an early stage is especially important if the positioner is used in a place of severe environment like coastal area.
- Before removing the positioner for maintenance or replacing unit parts after installation, make sure the supply pressure is shut off and all residual air pressure is released from piping.
- When the fixed orifice is clogged with carbon particles or others, remove the pilot valve unit Auto/Manual switch screw (built-in fixed orifice) and clean it by inserting a f0.2 wire into the aperture. If it must be replaced with a new one, stop the supply pressure and remove the stopper screw of the pilot valve unit.
- When disassembling the pilot valve, coat grease on the O-ring of the sliding section. (Use TORAY SILICONE SH45 grease)
- Check for air leaks from the compressed air piping. Air leaks could lower the performance characteristics of the positioner. Air is normally discharged from a bleed port, but this is necessary air consumption based on the construction of the positioner, and is not an abnormality if the air consumption is within the specified range.
- When replacing piping to change the operating direction, be sure to perform span adjustment (parameter code: C70).
- When removing the positioner from the actuator and mounting it onto another actuator, malfunctions may occur due to its retained initial constant. Therefore, when it is mounted onto other actuators, transmit the input current while cutting the air supply, and shift to parameter mode for adjustments.
- The balance current will change depending on the positioner orientation. Adjust the balance current (parameter code: C60) every time the orientation changes.

10 LIMITATIONS OF USE

WARNING:

- Do not exceed any of the specifications laid out in section 2 of this document or the specific product catalogue.
- Read thoroughly and understand the operation manual before operation of this product.

Revision History		
A	21/11/05	Revision History added for ATEX Technical Construction File
B	08/03/06	Notes regarding Safety Barrier output type and cable gland ATEX approval added.
C	25/04/06	Temp. for Dust certification increased from 60°C to 80°C.
D	02/04/08	Standards List removed, connections options updates

11 EUROPEAN CONTACT LIST

AUSTRIA	(43) 2262 62280	NETHERLANDS	(31) 20.531 8888
BELGIUM	(32) 3 355 1464	NORWAY	(47) 67 12 90 20
CZECH REP.	(420) 541 424 611	POLAND	(48) 22 211 9600
DENMARK	(45) 7025 2900	PORTUGAL	(351) 21 471 1880
FINLAND	(358) 207 513513	SLOVAKIA	(421) 2 444 56725
FRANCE	(33) 1 6476 1000	SLOVENIA	(386) 73 885 412
GERMANY	(49) 6103 4020	SPAIN	(34) 945 184 100
GREECE	(30) 210 271 7265	SWEDEN	(46) 8 603 1200
HUNGARY	(36) 23 511 390	SWITZERLAND	(41) 52 396 3131
IRELAND	(353) 1 403 9000	UNITED KINGDOM	(44) 1908 563888
ITALY	(39) 02 92711		

SMC Corporation

URL <http://www.smcworld.com> (Global) <http://www.smceu.com> (Europe)

Specifications are subject to change without prior notice from the manufacturer. The descriptions of products in this document may be used by other companies. © SMC Corporation All Rights Reserved.