

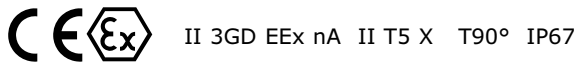

Installation and Maintenance Manual Series 56-SV 5 Port Solenoid Valve



Read this manual before using this product

- The information within this document is to be used by pneumatically trained personnel only.
- For future reference, please keep manual in a safe place.
- This manual should be read in conjunction with the current catalogue.

Marking description	
II 3GD EEx nA II T5 X T90° IP67	
-10°C ≤ Ta ≤ 50°C	
Group II	
Category 3	
Suitable for Gas and Dust environment	
Type of protection "Non-sparking apparatus"	

1 SAFETY RECOMMENDATION

1.1 General recommendation

These safety instructions are intended to prevent a hazardous situation and/or equipment damage. These instructions indicate the level of potential hazard by label of "Caution", "Warning" or "Danger". To ensure safety, be sure to observe ISO4414 ^(Note1), JIS B 8370 ^(Note2) and other safety practices.

Note 1:ISO 4414:Pneumatic fluid power - General rules relating to systems.

Note 2:JIS B 8370:Pneumatic system axiom.

	CAUTION: Operator error could result in injury or equipment damage.
	WARNING: Operator error could result in serious injury or loss of life
	DANGER: In extreme conditions, there is a possible result of serious injury or loss of life.

WARNING:

- The compatibility of pneumatic equipment is the responsibility of the person who designs the pneumatic system or decides its specifications.**
 - Since the products specified here are used in various operating conditions, their compatibility for the specific pneumatic system must be based on specifications or after analysis and/or tests to meet your specific requirements.
- Only trained personnel should operate pneumatically operated machinery and equipment.**
 - Compressed air can be dangerous if an operator is unfamiliar with it Assembly, handling or repair of pneumatic systems should be performed by trained and experienced operators.
- Do not service machinery/equipment or attempt to remove components until safety is confirmed.**
 - Inspection and maintenance of machinery/equipment should only be performed after confirmation of safe locked-out control positions.
 - When equipment is to be removed, confirm the safety process as mentioned above. Switch off air and electrical supplies and exhaust all residual compressed air in the system.
 - Before machinery/equipment is re-started, ensure all safety measures to prevent sudden movement of cylinders etc. (Bleed air into the system gradually to create backpressure, i.e. incorporate a soft-start valve).
- Contact SMC if the product is to be used in any of the following conditions:**
 - Conditions and environments beyond the given specifications, or if product is used outdoors.
 - Installations on equipment in conjunction with atomic energy, railway, air navigation, vehicles, medical equipment, food and beverage, recreation equipment, emergency stop circuits, press applications, or safety equipment.
 - An application, which has the possibility of having negative effects on people, property, or animals, requiring special safety analysis.

CAUTION:

- Ensure that the air supply system is filtered to 5 micron.

1.2 Conformity to standard

This product is certified to and complies with the following standards:

Electrical Apparatus for Potentially Explosive Gas Atmospheres	EN50014, EN 50021
Electrical Apparatus for Potentially Explosive Dust Atmospheres	EN 50281-1-1
Non-Electrical Equipment for Potentially Explosive Atmospheres	EN 13463-1
EMC (Electro Magnetic Compatibility)	EN 61000-6-2, EN 55011

1.3 Specific recommendations

WARNING:

- Not suitable for Zones 0/20 and Zones 1/21. Only suitable for Zones 2/22.
- When mounting this product, it must be installed such that, even in the event of rare incidents, ignition sources due to impact and friction sparks are excluded.
- Do not brush or wipe this product to avoid static charge build up. Static charge can cause a spark or ignition source.

Series 56-SV 5 port valve used as a 3 port valve

- Series 56-SV valves can be used as normally closed(N.C.) or normally open(N.O.) 3 port valves by closing one of the cylinder ports(A or B) with a plug. However they should be used with the exhaust ports kept open.
- They are convenient at times when a double solenoid type 3 port valve is required.

2 INTENDED CONDITIONS OF USE

2.1 Specifications

SERIES 56-SV SOLENOID VALVE SPECIFICATIONS

Fluid	Air	
Internal pilot operating pressure range MPa	2 position single	0.15 to 0.7
	4 position dual 3 port valve	0.15 to 0.7
	2 position double	0.1 to 0.7
	3 position	0.2 to 0.7
External pilot operating pressure range MPa	Operating pressure range	
	2 position single, double	-100kPa to 0.7
	3 position	0.25 to 0.7
Ambient and fluid temperature °C		-10 to 50 (with no freezing)
Maximum operating frequency Hz	2 position single, double	5
	4 position dual 3 port valve	5
	3 position	3
Manual override		Non-locking push type Slotted locking type
Pilot exhaust method	Internal pilot	Main valve/Pilot valve common exhaust
	External pilot	Pilot valve individual exhaust
Lubrication		Not required
Mounting orientation		Unrestricted
Impact/Vibration resistance ms ²		150/30 (8.3 to 2000Hz)
Enclosure		IP67 (based on IEC529)
Rated coil voltage		24VDC, 12VDC
Allowable voltage fluctuation		±10% of rated voltage
Power consumption W	initial value	0.62 (With light: 0.7)
	with power saving	0.24 (With light: 0.25)
Surge voltage suppressor		Diode
Indicator light		LED

Note) Impact resistance: No malfunction when tested with a drop tester in axial direction and at a right angle to the main valve and armature, one time each in energized and de-energized states (at initial valve).

Vibration resistance: No malfunction when tested with one sweep of 8.3 to 2000Hz in the axial direction and at a right angle to the main valve and armature, in both energized and de-energized states (at initial valve).

Production batch code

The production batch code printed on the label indicates the month and year of manufacture as in the following table.

Production batch code	See batch code on label											
Year of construction	Jan	Feb	Mar	Apr	May	June	July	Aug	Sep	Oct	Nov	Dec
2004	IO	IP	IQ	IR	IS	IT	IU	IV	IW	IX	IY	IZ
2005	JO	JP	JQ	JR	JS	JT	JU	JV	JW	JX	JY	JZ
2006	KO	KP	KQ	KR	KS	KT	KU	KV	KW	KX	KY	KZ
2007	LO	LP	LQ	LR	LS	LT	LU	LV	LW	LX	LY	LZ
2008	MO	MP	MQ	MR	MS	MT	MU	MV	MW	MX	MY	MZ
2009	NO	NP	NQ	NR	NS	NT	NU	NV	NW	NX	NY	NZ

2.2 Piping

Circular connector type tie-rod manifold

Valve series	Tubing O.D. [4(A),2(B) port]	Tubing O.D. [1(P),3/5(E) port]	Tubing O.D. [X external pilot port]	Tubing O.D. [PE pilot EXH port]
56-SV1000	Ø3.2, Ø4, Ø6, N1, N3, N7	Ø8, N9	Ø4, N3	Ø4, N3
56-SV2000	Ø4, Ø6, Ø8, N3, N7, N9	Ø10, N11	Ø4, N3	Ø4, N3
56-SV3000	Ø6, Ø8, Ø10, N7, N9, N11	Ø12, N11	Ø6, N7	Ø6, N7

56-SV4000 Series	[4(A),2(B) port]	[1(P),3/5(E) port]	[X external pilot port]	[PE pilot EXH port]
Tubing O.D.	Ø8, Ø10, Ø12, N9, N11	Ø12, N11	Ø6, N7	Ø6, N7
Threaded Fitting size	Rc 1/4, 3/8, NPT 1/4, NPT 3/8 G 1/4, 3/8, NPTF 1/4, NPTF 3/8	Rc 3/8, NPT 3/8 G 3/8, NPTF 3/8		

EX500 Decentralized serial wiring type tie-rod manifold

Valve series	Tubing O.D. [4(A),2(B) port]	Tubing O.D. [1(P),3/5(E) port]	Tubing O.D. [X external pilot port]	Tubing O.D. [PE pilot EXH port]
56-SV1000	Ø3.2, Ø4, Ø6, N1, N3, N7	Ø8, N9	Ø4, N3	Ø4, N3
56-SV2000	Ø4, Ø6, Ø8, N3, N7, N9	Ø10, N11	Ø4, N3	Ø4, N3
56-SV3000	Ø6, Ø8, Ø10, N7, N9, N11	Ø12, N11	Ø6, N7	Ø6, N7

56-SV4000 Series	[4(A),2(B) port]	[1(P),3/5(E) port]	[X external pilot port]	[PE pilot EXH port]
Tubing O.D.	Ø8, Ø10, Ø12, N9, N11	Ø12, N11	Ø6, N7	Ø6, N7
Threaded Fitting size	Rc 1/4, 3/8, NPT 1/4, NPT 3/8 G 1/4, 3/8, NPTF 1/4, NPTF 3/8	Rc 3/8, NPT 3/8 G 3/8, NPTF 3/8		

2.3 Circuit Symbols

JIS Symbols

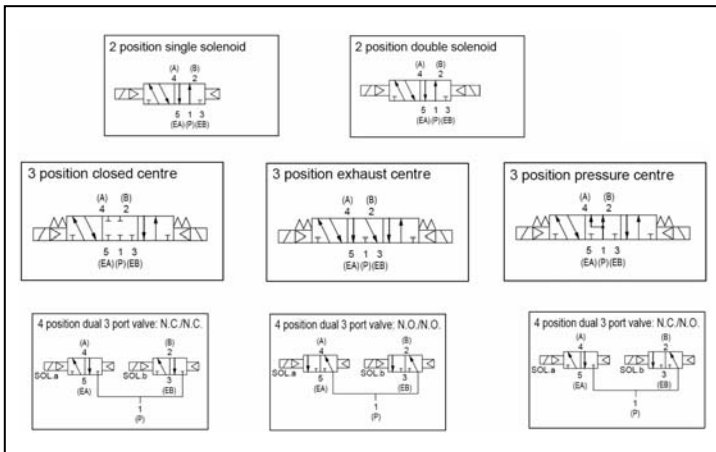

2.4 Electrical entry

- Circular connector**

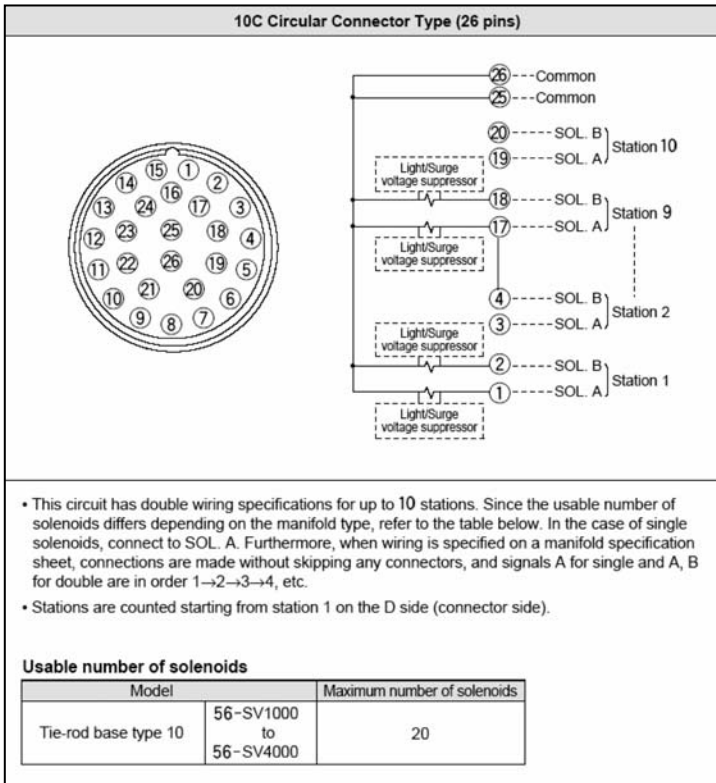

- EX500 Decentralized serial wiring**

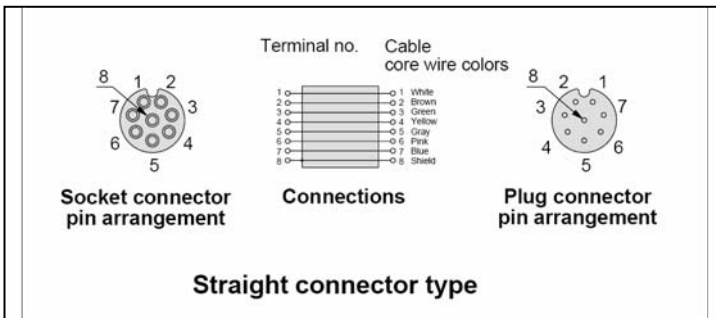

3 INSTALLATION

WARNING:

- Do not install unless the safety instructions have been read and understood.

3.1 Environment

WARNING:

- Do not use in an environment where the product is directly exposed to corrosive gases, chemicals, salt water, water or steam.
- Do not use in an explosive atmosphere not covered by ATEX group II category 3GD.
- The product should not be exposed to prolonged sunlight. Use a protective cover.
- Do not mount the product in a location where it is subject to strong vibrations and/or shock. Check the product specifications for above ratings.
- Do not mount the product in a location where it is exposed to radiant heat.

3.2 Piping

CAUTION:

- Before piping make sure to clean up chips, cutting oil, dust etc.
- When installing piping or fitting into a port, ensure that sealant material does not enter the port inside. When using seal tape, leave 1.5 to 2 threads exposed on the end of pipe/fitting.

Series	Appropriate tightening torque (Nm)
Rc 1/8	7 to 9
Rc 1/4	12 to 14
Rc 3/8	22 to 24
Rc 1/2	28 to 30

One-touch fittings:

CAUTION:

Tube attachment

- Take a tube having no flaws on its periphery and cut it off at a right angle. When cutting the tube, use tube cutters TK-1, 2 or 3. Do not use pincers, nippers or scissors etc. If cutting is done with tools other than tube cutters, the tube may be cut diagonally or become flattened etc., making a secure installation impossible, and causing problems such as the tube pulling out after installation or air leakage. Allow some extra length in the tube.
- Grasp the tube and push it in slowly, inserting it securely all the way into the fitting.
- After inserting the tube, pull on it lightly to confirm that it will not come out. If it is not installed securely all the way into the fitting this can cause problems such as air leakage or the tube pulling out.

Tube detachment

- Push in the release bushing sufficiently and push the collar at the same time.
- Pull out the tube while holding down the release bushing so that it does not come out. If the release bushing is not pressed down sufficiently there will be increased bite on the tube and it will become more difficult to pull out.
- When the removed tube is to be used again, cut off the portion which has been chewed before re-using it. If the chewed portion of the tube is used as is, this can cause trouble such as air leakage or difficulty in removing the tube from the fitting.

Precautions on other tube brands

CAUTION:

- When using other than SMC brand tubes, confirm that the following specifications are satisfied with respect to the outside diameter tolerance of the tube.

Nylon tube	±0.1mm
Soft nylon tube	±0.1mm
Polyurethane tube	+0.15mm - 0.2mm

- Do not use tubes that do not meet these outside diameter tolerances. It may not be possible to connect them, or they may cause other problems, such as air leakage or the tube pulling out after connection.

3.3 Electrical connection

- ⚠ DANGER:**
- Disconnect power supply before removing or making any electrical connections.

- ⚠ CAUTION:**
- Be careful to apply the proper voltage when connecting electric power to the solenoid valve. Application of improper voltage may cause malfunction or damage.

Indication mark of manifold

- Manifold block for series 56-SV are marked with "S" or "D" as following diagram. This mark indicates the type of board assembly(for single wiring or double wiring) which is mounted inside the manifold block.
- All stations will be double wiring specification (D) unless wiring method is specified in a manifold specification.
- In this case, either single or double valve can be mounted, however, when single valve is used, there will be blank number in the control signal. To avoid making blank number, please indicate position of the manifold block by manifold specification, whether single wiring (S) or double wiring (D) is required.(Please note that double 3 position or 4 position valve cannot be used for manifold block with single wiring specification (S).)

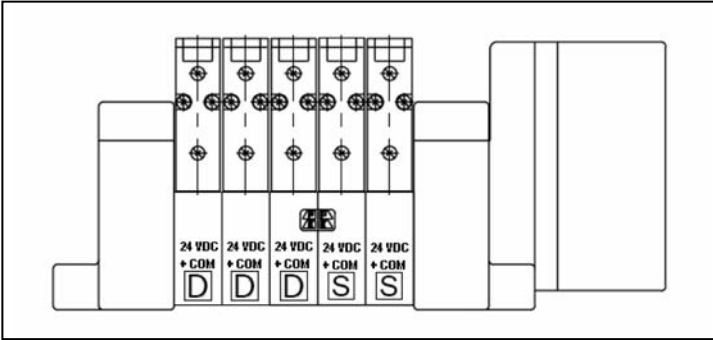

⚠ CAUTION:
Circuit board assembly assembled into manifold

- Circuit board assembly installed into manifold cannot be disconnected. Disconnecting by force may damage components.

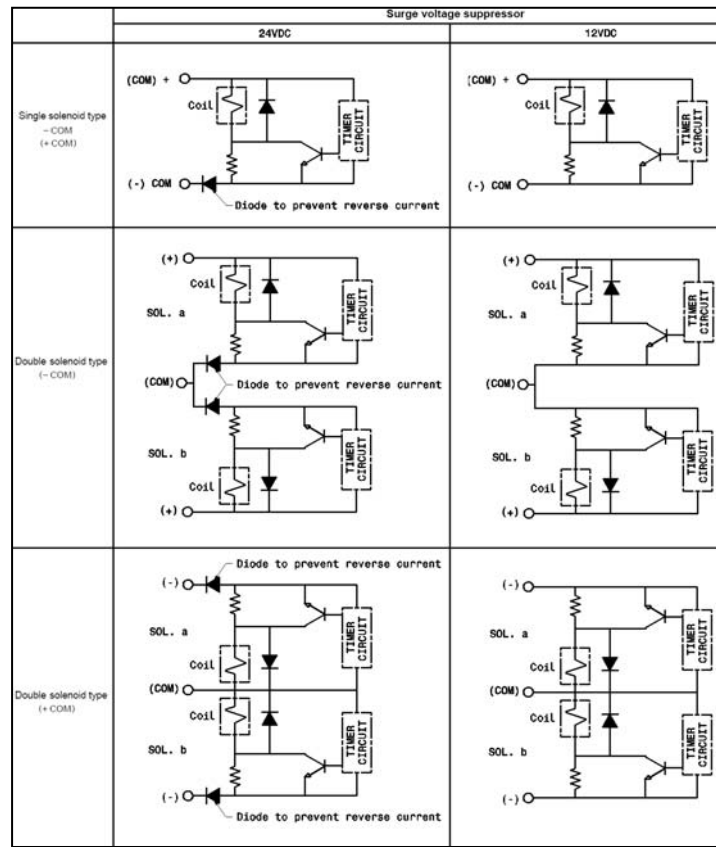
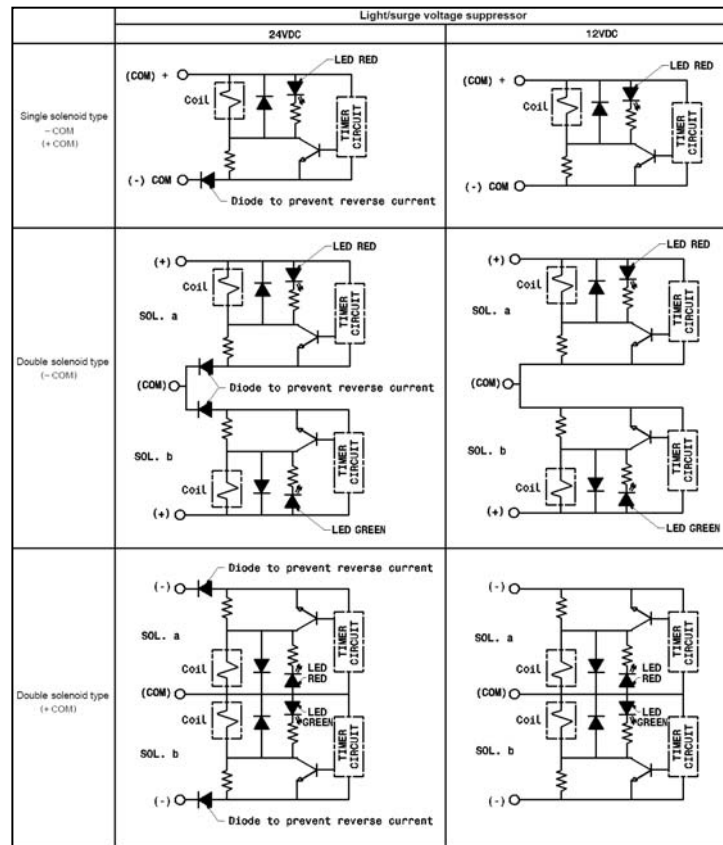

3.4 Mounting

- ⚠ DANGER:**
- Never add or remove a valve from the manifold when energised.
 - Never disconnect or reconnect cables or connectors when power is connected to manifold.

- ⚠ CAUTION:**
- Be sure to cut off power and the air supply and confirm that no air is left in actuators, piping and manifolds before disassembling, as remaining air may cause an accident.
 - If the connection between blocks or tightening of the tie-rod screws is insufficient, it may cause air leakage. Before supplying air, check that there is no clearance between the blocks, and the manifold blocks are firmly mounted on the DIN rail in order to ensure air supply without leakage.
 - Before assembly and installations, confirm that rubber parts such as gaskets and O-rings are assembled to every block. If rubber parts are missing, air leakage may occur and the specifications of IP65 and IP67 cannot be satisfied.

Removal and fitting of protective covers

- ⚠ WARNING:**
- Be sure to re-assemble protective covers after removal, or this will invalidate the ATEX rating.

Type 10C Circular connector type tie-rod manifold

- To remove protective cover, undo the two M4 screws and withdraw cover from over the valves. Assembly is in the reverse order, torque tighten screws to 0.72 to 0.88Nm.
- The protective cover over the circular connector can be removed to allow access to the connector by loosening the two M4 screws and sliding the cover away from the connector. Assembly is in the reverse order, torque tighten screws to 0.33 to 0.40Nm.

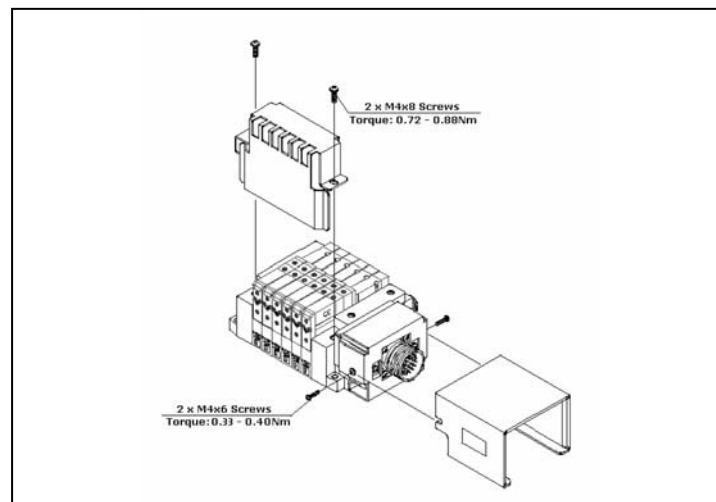

EX500 Decentralized serial wiring type tie-rod manifold

- To remove protective cover, undo the two M4 screws and withdraw cover from over the valves. Assembly is in the reverse order, torque tighten screws to 0.72 to 0.88Nm.

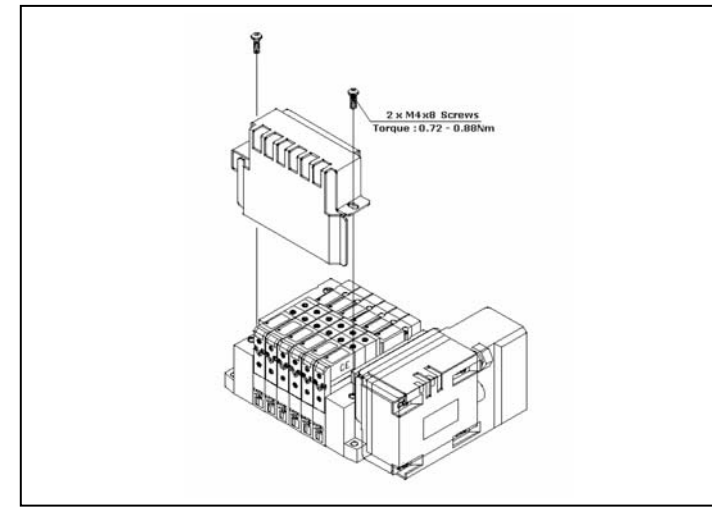

Removal/assembly of valve

Note: Before valves/stations can be removed or assembled, protective cover must be removed.

- Remove screws and gently lift valve from manifold.
- Ensure seals are present before re-assembling valve. Torque tighten screws as shown in table.

Series	Appropriate tightening torque (Nm)
56-SV1000	0.15Nm
56-SV2000	0.6Nm
56-SV3000	1.4Nm
56-SV4000	0.6Nm

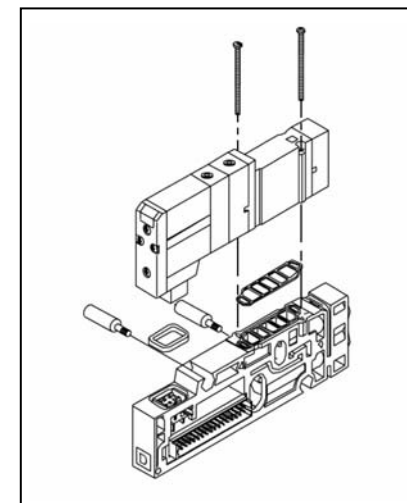

Removal and adding stations

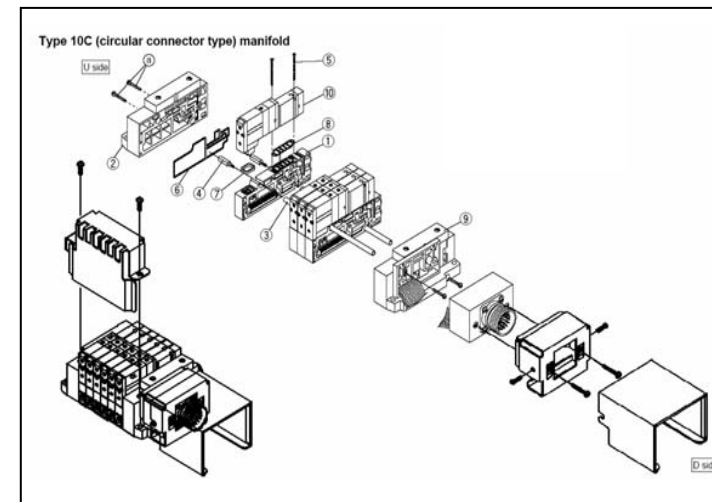

Note: Adding (or removing) stations, must be done in pairs (a blanking plate can be used if only one valve is needed). This is because a new protective cover will be required for the different number of stations. Protective covers are available for 4, 6, 8 and 10 stations.

Type 10C (circular connector) and Series EX500 serial wiring manifold (tie-rod type)

- To add another station, loosen bolts ② on the U side to dismount the SUP/EXH end block assembly ① (maximum number of stations is 10).
- Screw in the additional tie-rod ④ until there is no clearance between the tie-rods.
- Ensure all seals are present and connect the additional block manifold assembly to the SUP/EXH end block assembly and remount to the manifold assembly, tightening the bolts ③ to torque shown in table.

Series	Appropriate tightening torque (Nm)
56-SV1000	0.6Nm
56-SV2000	0.6Nm
56-SV3000	1.4Nm
56-SV4000	2.9Nm

Note: For reducing the number of stations, order the required tie-rods ③ for the reduced manifold.

3.5 Lubrication

- ⚠ CAUTION:**
- SMC products have been lubricated for life at manufacturer, and do not require lubrication in service.
 - If a lubricant is used in the system, use turbine oil Class 1(no additive), ISO VG32. Once lubricant is used in the system, lubrication must be continued because the original lubricant applied during manufacturing will be washed away.

4 SETTINGS AND PROGRAMMING

4.1 Manual override

- ⚠ WARNING:**
- Since connected equipment will operate when manual override is performed, first confirm conditions are safe.
 - Non-locking push type
 - Push down on the manual override button, until it stops ON, using a small-bladed screwdriver.
 - Hold this position for the duration of the check(ON position).
 - Release the button and the override will re-set to OFF position.

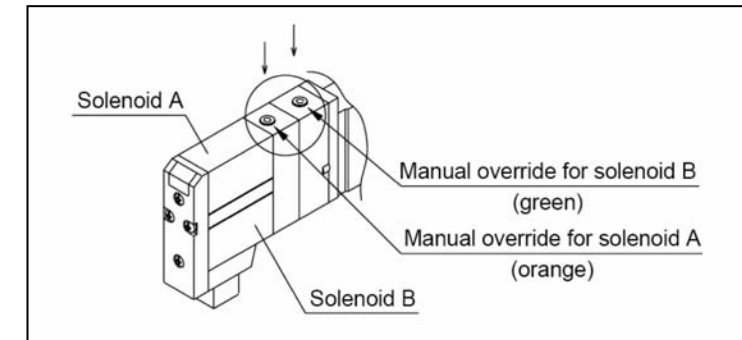

- Push-locking slotted type
 - To lock
 - Using a small-bladed screwdriver in the slot, push the manual override button down until it stops.
 - Turn the override button 90° in the direction of the arrow until it stops (ON position).
 - Remove the screwdriver.

- ⚠ WARNING:**
- In this position the manual override is in the locked 'ON' position.
- To unlock
 - Place a small-bladed screwdriver in the slot, push the manual override button.
 - Turn the override button 90° in the reverse direction of the arrow.
 - Remove the screwdriver and the manual override will re-set to the OFF position.

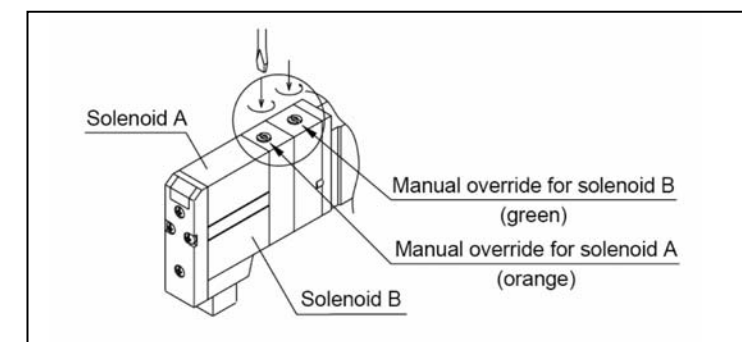

4.2 Light indication

⚠ CAUTION:

- In the case of light/surge voltage suppressor, the light window turns orange when solenoid A is energised, and it turns green when solenoid B is energised.

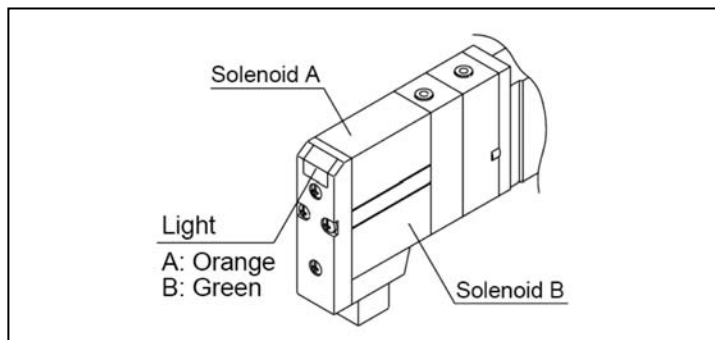

5 MAINTENANCE

⚠ WARNING:

- Not following proper procedures could cause the product to malfunction and could lead to damage to the equipment or machine.
- If handled improperly, compressed air can be dangerous. Assembly, handling and repair of pneumatic system should be performed by qualified personnel only.
- Drain: remove condensate from the filter bowl on a regular basis.
- Shut-down before maintenance: before attempting any kind of maintenance make sure the supply pressure is shut off and all residual air pressure is released from the system to be worked on.
- Start-up after maintenance: apply operating pressure and power to the equipment and check for proper operation and possible air leaks. If operation is abnormal, please verify product set-up parameters.
- Do not make any modification to the product
- Do not disassemble the product, unless required by installation or maintenance instructions.
- Ensure protective covers are not damaged and are re-assembled after maintenance. If these covers are not re-assembled, this will invalidate the ATEX rating.

5.1 Replacement of fittings

- By replacing a valve's fitting assembly, it is possible to change the connection diameter of the A and B ports.
- To replace a valve fitting assembly, remove the clip using a flat blade screwdriver, then pull out the fitting assembly. To mount a new fitting assembly, insert it into place and then fully reinsert the clip.

⚠ CAUTION:

- Before disassembly, be sure to turn off electric power and air supplies. Also, since air may still remain inside actuators, piping and manifolds, confirm that the air has been completely exhausted before performing any work.
- Take care not to get scratches or dirt etc. on the O-rings, as this can cause air leakage.
- When removing a fitting assembly from a valve, after removing the clip, connect a tube or plug (KQP-##) to the one-touch fitting and pull it out by holding the tube (or plug). If the fitting assembly is pulled out by holding its release bushing (resin part), the release bushing maybe damaged. However, for port block assembly (02 and 03), maybe pulled out as it is.

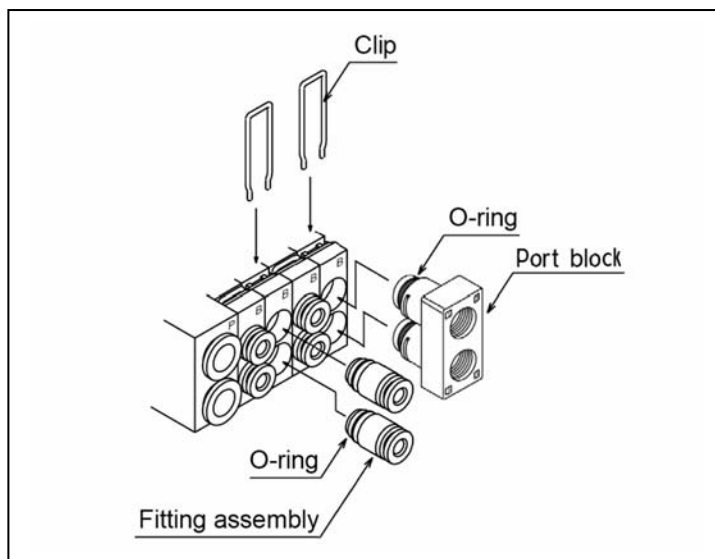

5.2 Blanking plate assembly

- For blanking off any spare stations on the manifold assembly.
- Assemble blanking plate to manifold block ensuring gasket is present.
- Torque tighten mounting screws as shown in table.

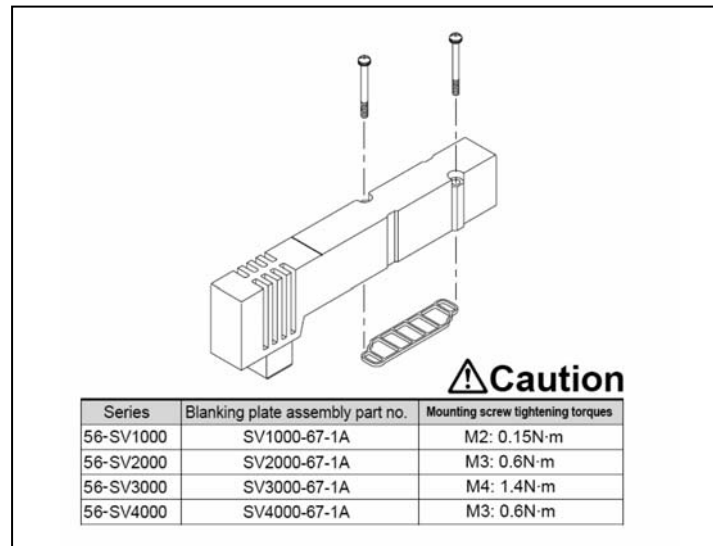

6 LIMITATIONS OF USE

⚠ WARNING:

- Do not exceed any of the specifications laid out in section 2 of this document or the specific product catalogue.
- Ensure all air and power supplies are ISOLATED before commencing installation.
- Do not use in atmosphere where the valve is in direct contact with corrosive gases, chemicals, salt water, water or steam. However products with IP65 enclosure or IP67 (per IEC529) are protected against dust or water, but are not suitable for use under water.
- Specification of product with IP65 enclosure or IP67 is satisfied by mounting each product appropriately. Please thoroughly read cautions for each product.
- If it is intended to energise a valve for an extended period of time, please consult SMC.
- These valves are NOT intended to be used as emergency shut-off valves.
- Double solenoid valves must be energised for AT LEAST 0.1 seconds to ensure correct operation.
- DO NOT use these valves down to -10°C.
- Mount double solenoid 3 position valves with spool horizontal.
- Ensure valves are operated within the specification range.
- All valve series have POLARITY.

7 EUROPEAN CONTACT LIST

7.1 SMC Corporation

Country	Telephone	Country	Telephone
Austria	(43) 2262-62 280	Italy	(39) 02-92711
Belgium	(32) 3-355 1464	Netherlands	(31) 20-531 8888
Czech Republic	(420) 5-414 24611	Norway	(47) 67 12 90 20
Denmark	(45) 70 25 29 00	Poland	(48) 22-548 50 85
Finland	(358) 9-859 580	Portugal	(351) 22 610 89 22
France	(33) 1-64 76 1000	Spain	(34) 945-18 4100
Germany	(49) 6103 4020	Sweden	(46) 8 603 12 00
Greece	(30) 1- 342 6076	Switzerland	(41) 52-396 3131
Hungary	(36) 23 511 390	Turkey	(90) 212 221 1512
Ireland	(353) 1-403 9000	United Kingdom	(44) 1908-56 3888

7.2 Websites

SMC Corporation	www.smcworld.com
SMC Europe	www.smc.eu.com