



Installation and Maintenance Manual

Series 56-IS1000, 56-IS1000E, 56-IS1000M

Mechanical Pressure Switch



II 3GD EEx nA II T5 Ta-5°C to 60°C T90°C
IP67 / IP40

Read this manual before using this product

- The information within this document is to be used by pneumatically trained personnel only.
- For future reference, please keep manual in a safe place.
- This manual should be read in conjunction with the current catalogue.

ATEX marking description

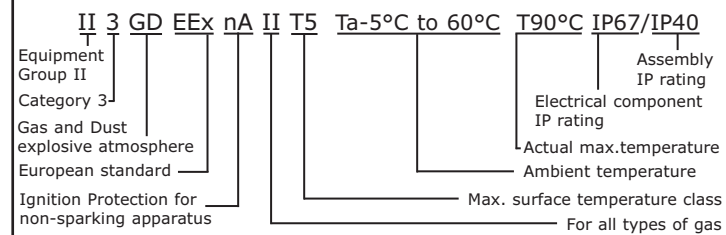

1 SAFETY RECOMMENDATION

1.1 General recommendation

These safety instructions are intended to prevent a hazardous situation and/or equipment damage. These instructions indicate the level of potential hazard by label of "Caution", "Warning" or "Danger". To ensure safety, be sure to observe ISO4414 (Note1), JIS B 8370 (Note2) and other safety practices.

Note 1:ISO 4414:Pneumatic fluid power - General rules relating to systems.
Note 2:JIS B 8370:Pneumatic system axiom.

CAUTION: Operator error could result in injury or equipment damage.

WARNING: Operator error could result in serious injury or loss of life.

DANGER: In extreme conditions, there is a possible result of serious injury or loss of life.

WARNING:

- The compatibility of pneumatic equipment is the responsibility of the person who designs the pneumatic system or decides its specifications.
 - Since the products specified here are used in various operating conditions, their compatibility for the specific pneumatic system must be based on specifications or after analysis and/or tests to meet your specific requirements.
- Only trained personnel should operate pneumatically operated machinery and equipment.
 - Compressed air can be dangerous if an operator is unfamiliar with it. Assembly, handling or repair of pneumatic systems should be performed by trained and experienced operators.
- Do not service machinery/equipment or attempt to remove component until safety is confirmed.
 - Inspection and maintenance of machinery/equipment should only be performed after confirmation of safe locked-out control positions.
 - When equipment is to be removed, confirm the safety process as mentioned above. Switch off air and electrical supplies and exhaust all residual compressed air in the system.
 - Before machinery/equipment is re-started, ensure all safety measures to prevent sudden movement of cylinders etc. (Bleed air into the system gradually to create backpressure, i.e. incorporate a soft-start valve).
- Contact SMC if the product is to be used in any of the following conditions:
 - Conditions and environments beyond the given specifications, or if product is used outdoors.
 - Installations in conjunction with atomic energy, railway, air navigation, vehicles, medical equipment, food and beverage, recreation equipment, emergency stop circuits, press applications, or safety equipment.
 - An application, which has the possibility of having negative effects on people, property, or animals, requiring special safety analysis.

CAUTION:

- Ensure that the air supply system is filtered to 5 micron.

1.2 Conformity to standard

This product is certified to and complies with the following standards:

ATEX Directive 94/9/EC

- EN 50021:1999 Electrical apparatus for potentially explosive atmospheres - Type of protection 'n'
- EN 50281-1-1:1999 Electrical apparatus protected by enclosures - construction and testing
- EN 13463-1:2001 Non-electrical equipment for potentially explosive atmospheres - basic methods and requirements

EMC Directive 89/336/EEC

- EN 60947-5-2:1998 Specification for low voltage switchgear & control gear. Control circuit devices and switching elements, Proximity switches
- EN 55011:1998+A1 Limits and methods of measurement of radio disturbance characteristics of industrial, scientific and medical (ISM) - radio-frequency equipment

2 INTENDED CONDITIONS OF USE

2.1 Specifications

Model (standard)	56-IS1000
Proof Pressure	1.0 MPa
Maximum Operating Pressure	0.7 MPa
Pressure Range (at OFF point)	0.1 - 0.4 MPa
Hysteresis	0.08 MPa or less
Error of scale	±0.05 MPa
Repeatability	±0.05 MPa
Contacts	1a
Electrical Entry	Grommet - lead wire length 0.5m (standard)
Fluid	Air / Inert Gas
Ambient and Fluid Temperature	-5°C to 60°C
Air connection Port size	R (PT) 1/8
Weight	74 g

2.2 Proximity Switch Characteristics

Proximity Switch type	Reed Switch	
Wiring Style	2 wire	
Maximum Contact Capacity	AC 2 VA , 2 W DC	
Voltage	24V AC/DC or less	48V AC/DC or less
Maximum Load Current	50mA	40mA
Shock Resistance	30G	

2.3 Setting Pressure Range

- Pressure adjustment is carried out via the regulation screw (item 5).
- Set the pressure scale at the value of the pressure required on the scale plate (item 8).
- In applications where the ON pressure is being detected, please note that the indication on the scale plate, will be the OFF pressure. The ON pressure will be made up of the 'SET' pressure plus the ON-OFF differential (or hysteresis).

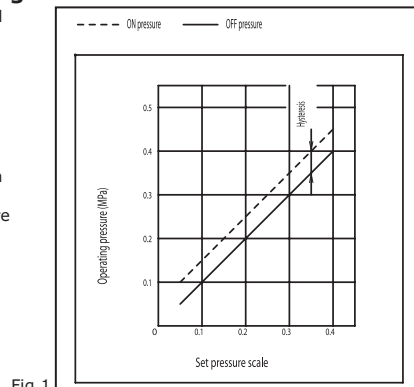

Fig 1

2.4 Pressure Switch Construction / Parts List

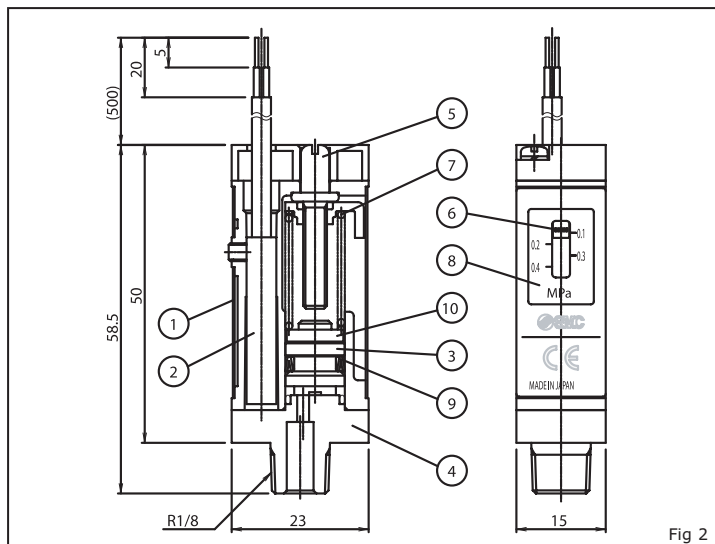

Fig 2

No.	Description	Material	Specification
1	Shield Plate	Steel Plate	
2	Reed Switch	-	
3	Piston	Polyacetal	
4	Fittings	Zinc die-cast	
5	Regulation screw	Brass	
6	Pointer	Brass	
7	Spring	Stainless Steel	SUS304 WPB
8	Scale Plate	PC	
9	Piston seal Y type	NBR	
10	Magnet	Rare Earth magnet	

The drawing shows the standard model 56-IS1000

Refer to Best Pneumatics, Air Combination (AC) series for IS1000E and IS1000M

2.5 How to Order

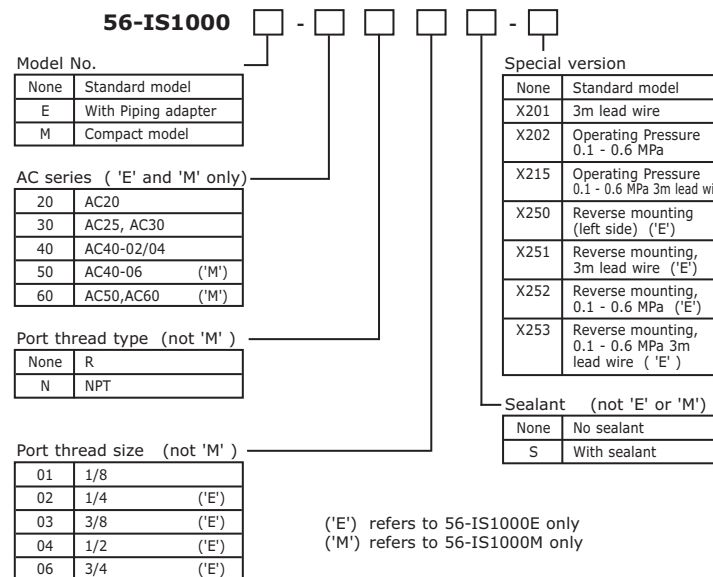

3 INSTALLATION

WARNING:

- Do not install unless the safety instructions have been read and understood.
- Ensure all air and power supplies are ISOLATED before commencing with installation.
- Do not carry the pressure switch by the reed switch lead wire, as this may cause broken wires, or may stress internal elements of the switch.

3.1 Environment

WARNING:

- Do not use in an environment where the product is directly exposed to corrosive gases, oil, chemicals, salt water, water or steam.
- The product should not be exposed to prolonged sunlight. This could generate surface temperatures outside the ATEX temperature classification. Use a protective cover.
- Do not mount the product in a location where it is subject to strong vibrations and/or shock. Check the product specifications for above ratings.
- Do not mount the product in a location where it is exposed to radiant heat.
- Do not use in an environment where a magnetic field is generated. The proximity switch can malfunction.

3.2 Piping

CAUTION:

- Before piping make sure to clean up chips, cutting oil, dust etc.
- When installing piping, ensure that sealant material does not enter the port inside. When using seal tape, leave 1.5 to 2 threads exposed on the end of pipe/fitting.
- When installing or removing piping, ensure that the body of the pressure switch is securely held (Fig 4). Do not apply stress to the electrical wiring.

Thread	Tightening torque (Nm)
1/8	7 to 9
1/4	12 to 14
3/8	22 to 24
1/2	28 to 30
3/4	28 to 30

Fig 3

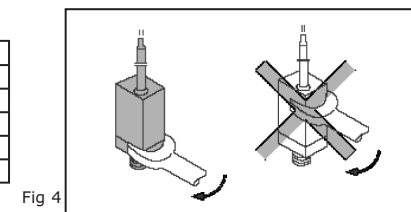

Fig 4

3.3 Electrical connection

CAUTION:

- The product may be damaged or malfunction if it is used outside of the range of specifications for operating current, voltage or temperature.
- Pay attention to the length of time that the reed switch is ON, at the intermediate stroke position. For information please consult SMC.
- Keep the reed switch wiring as short as possible. The longer the wire, the greater the rush current at switching ON.
- For inductive load applications, or where the lead wire is greater than 5m long, an SMC contact protection box (CD-P12) must be used.
- Avoid repeatedly bending or stretching the lead wires.
- Be sure to connect the load before power is applied. If the power is turned ON without a load, the switch will be damaged due to excess current.
- Confirm proper insulation of wiring.

3.4 Electrical Wiring

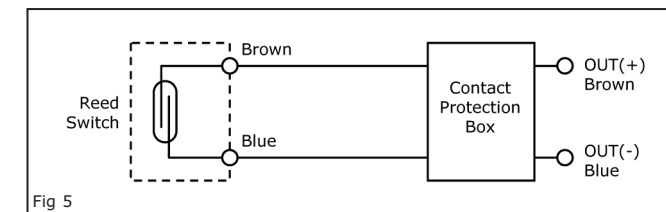

Fig 5

3.5 Lubrication

CAUTION:

- SMC products have been lubricated for life at manufacturer, and do not require lubrication in service.

4 MAINTENANCE

WARNING:

- Not following proper procedures could cause the product to malfunction and could lead to damage to the equipment.
- If handled improperly, compressed air can be dangerous. Assembly, handling and repair of pneumatic systems should be performed by qualified personnel only.
- Shut-down before maintenance: before attempting any kind of maintenance make sure the supply pressure is shut off and all residual air pressure is released from the system to be worked on.
- Start-up after maintenance: apply operating pressure and power to the equipment and check for proper operation and possible air leaks. If operation is abnormal, please verify product set-up parameters.
- Do not make any modification to the product.
- Do not disassemble the product, unless required by installation or maintenance instructions.
- Confirm that there is no damage to the lead wires, to avoid faulty insulation.

5 EUROPEAN CONTACT LIST

5.1 SMC Corporation

Country	Telephone	Country	Telephone
Austria	(43) 2262-62 280	Italy	(39) 02-92711
Belgium	(32) 3-355 1464	Netherlands	(31) 20-531 8888
Czech Republic	(420) 5-414 24611	Norway	(47) 67 12 90 20
Denmark	(45) 70 25 29 00	Poland	(48) 22-548 50 85
Finland	(358) 9-859 580	Portugal	(351) 22 610 89 22
France	(33) 1-64 76 1000	Spain	(34) 945-18 4100
Germany	(49) 6103 4020	Sweden	(46) 8 603 12 00
Greece	(30) 1- 342 6076	Switzerland	(41) 52-396 3131
Hungary	(36) 23 511 390	Turkey	(90) 212 221 1512
Ireland	(353) 1-403 9000	United Kingdom	(44) 1908-56 3888

5.2 Websites

SMC Corporation	www.smcworld.com
SMC Europe	www.smceu.com