OPERATION MANUAL

Input Block

EX250-IE1

EX250-IE2

EX250-IE3

Contents

1.Precautions	-----	P2
2.Specifications		
2-1 General specification	-----	P4
2-2 Input specification	-----	P4
3.Wiring and setting		
3-1 Input wiring	-----	P5
3-2 Installation and maintenance	-----	P13
3-3 Input selector switch	-----	P16
4.LED indicator and Physical dimensions		
4-1 LED indication	-----	P16
4-2 Physical dimensions	-----	P17
5.Trouble Shooting	-----	P19

1. Precaution

Following safety requirements aim at the prevention of hazardous condition and the damage of instruments. Here, the hazard is classified in “Dangerous”, “Warning” and “Caution” on the level of hazard.

Please refer to regulation of safety on ISO and JIS to ensure safety.



Warning : Operator error may cause the death or serious injury.



Caution : Operator error may cause the injury or equipment damage.



Warning

1. The product is designed to use in ordinary full automation equipment. Don't use this product in equipment or instrument where human life may be directly injured or malfunction of failure may cause devastating loss.
2. Don't disassemble the product to repair and modification.



Caution

Read this operation manual carefully to ensure the safety and proper operation.

Design, Selection

1. See the specification
 - Keep all requirements in the specification (Voltage, operating ambient temperature, impact) to avoid damage, malfunction and fire.
2. Specified maintenance space is necessary
 - Design must consider the space necessary for maintenance.

Installation, Adjustment, Wiring

1. Don't drop nor hit the unit
 - Don't apply impact more than 100m/s². Internal parts of Input Block may be damaged and malfunction.
2. Wire properly
 - Input Block may damage by improper wiring.
3. Don't wire power supply line and high power line together
 - Wire Input Block wiring (piping) and power line/high power line separately to avoid interference of noise and surge from high power line to the signal line.
4. Ensure the insulation of wiring
 - Insulation failure (mixture with other circuit, insulation between terminals etc.) may cause excessive voltage or current to Input Block which leads to damage the Input Block.

5. Keep the tightening torque

The screw should be tighten with the specified torque, otherwise IP67 protection can not be guaranteed.

6. Don't apply repeated bend and tensile force

Wiring applying repeated bending stress and tensile force lead to cause disconnection.

Operating Condition

1. Never use in explosive environment

Input Block is not explosion proof. Operation in explosive environment may cause explosion accident.

2. Don't apply temperature cycle

Temperature cycle other than normal temperature change do harm to the internal part of Input Block.

3. Don't use where exposed to surge source

Device and instrument which generate big surge (Electromagnetic lifter, High frequency induction furnace, motor etc.) adjacent to the manifold solenoid valve with Input Block lead to cause the deterioration or damage of the switch internal circuit element. Consider the solution against surge and do not to mix lines.

4. Bits of wire and other foreign materials should not enter the product

Bits of wire and other foreign materials in Input Block may cause fire, failure or malfunction.

5. Mounting of Input Block on manifold and wiring from the conduit shall be treated as specified

Otherwise IP67 rating cannot be attained.

Maintenance

1. Periodic maintenance is recommended to avoid unexpected failure and malfunction.

2. Don't touch the terminal and internal board during energization to avoid malfunction, unit damage, and electric shock.

2.Specifications

2-1 General specification

Item	Specification
Operating ambient temperature	+5 to +45°C
Operating ambient humidity	35 to 85 % RH (No dew condensation)
Storage ambient temperature	-20 to +60°C
Vibration proof	10 to 57 Hz 0.35 mm (constant amplitude) 57 to 150 Hz 50 m/s ² (constant acceleration)
Impact proof	150 m/s ² (peak), 11ms × three times in each direction ±X,Y and Z.
Noise immunity	Normal mode : ±1500 V Pulse duration 1us Common mode : ±1500 V Pulse duration 1us Radiation : ±1000 V Pulse duration 1us
Operating environment	No corrosive gas and no dust

2-2 Input specification

Item	Specification		
	EX250-IE1	EX250-IE2	EX250-IE3
Part number	EX250-IE1	EX250-IE2	EX250-IE3
Input point	2 points	4 points	4 points
Input connector	M12 connector	M12 connector	M8 connector
Standard	IEC1131-2		
Corresponding sensors	Current source type (PNP output) Current sink type (NPN output) *1		
Rated voltage Ue	24V DC *2		
Logic "1" input voltage UH	+11 to +30V		
Logic "0" input voltage UL	-3 to +5V		
Logic "1" input current IH	8 mA Typ.		
Two wire sensor connection	Possible		
Logic "0" allowable current IL	2.5mA Max.		
Sensor supply current	120mA/Input Block(30mA/sensor)*3		
Short-circuit protection	Fuse cut over 500mA each Input Block		

*1) Change-over by switch (for changing the whole Input Block)

*2) About 1V of voltage drop for power supply voltage (power for SI unit and Input Block)

*3) When extended Input Block and used 32 sensors, total of sensor supply current should not be over 1A.

3.Wiring and setting

3-1 Input wiring

EX250-IE1 input circuit construction

(1) NPN sensor

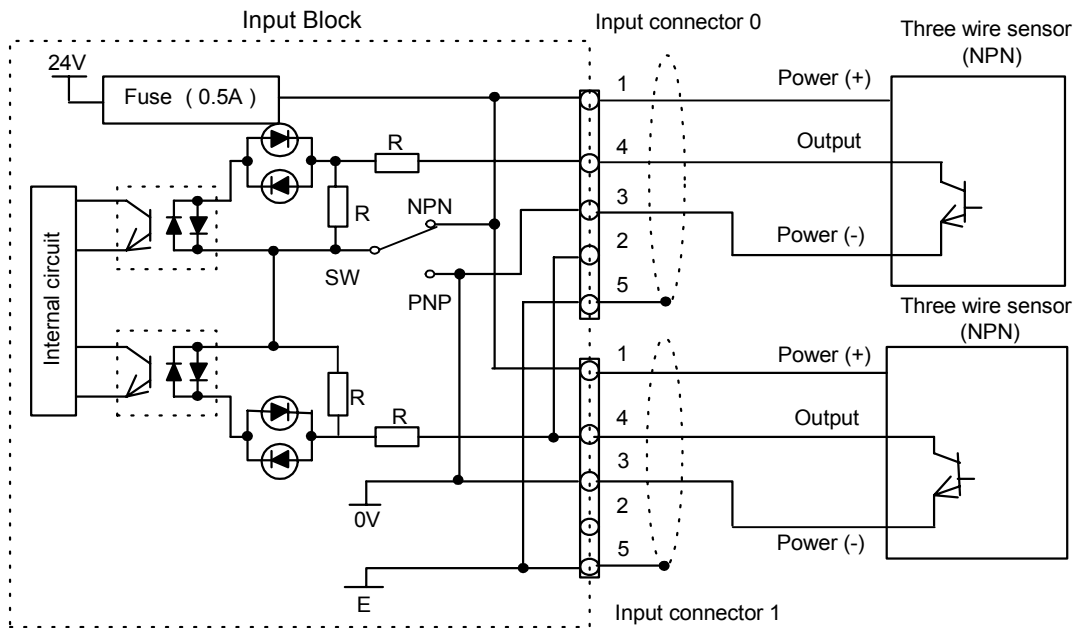

(2) PNP sensor

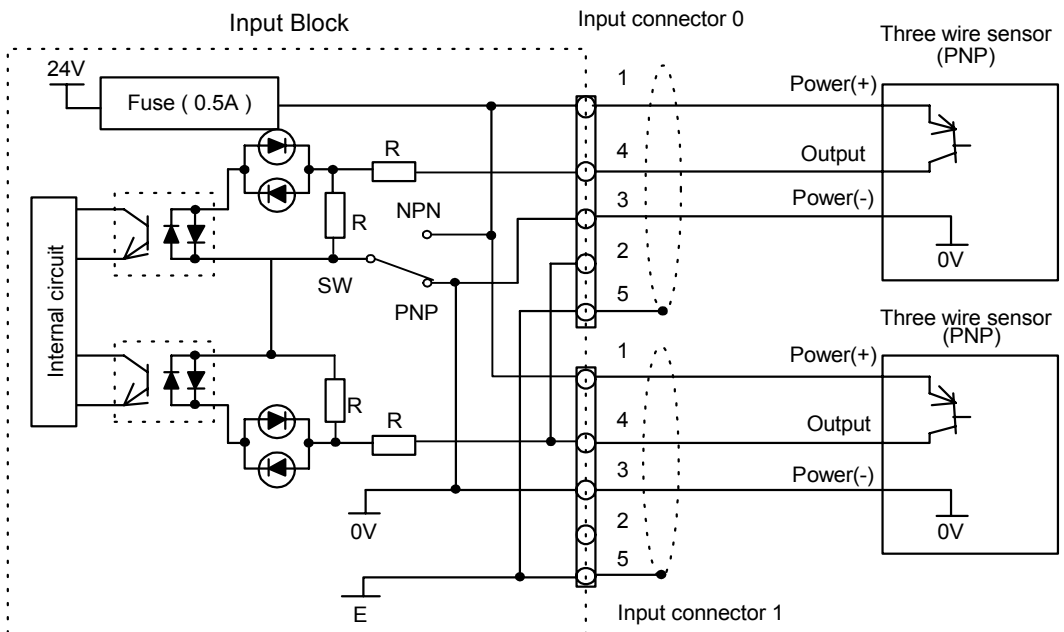

(3) Two wire sensor

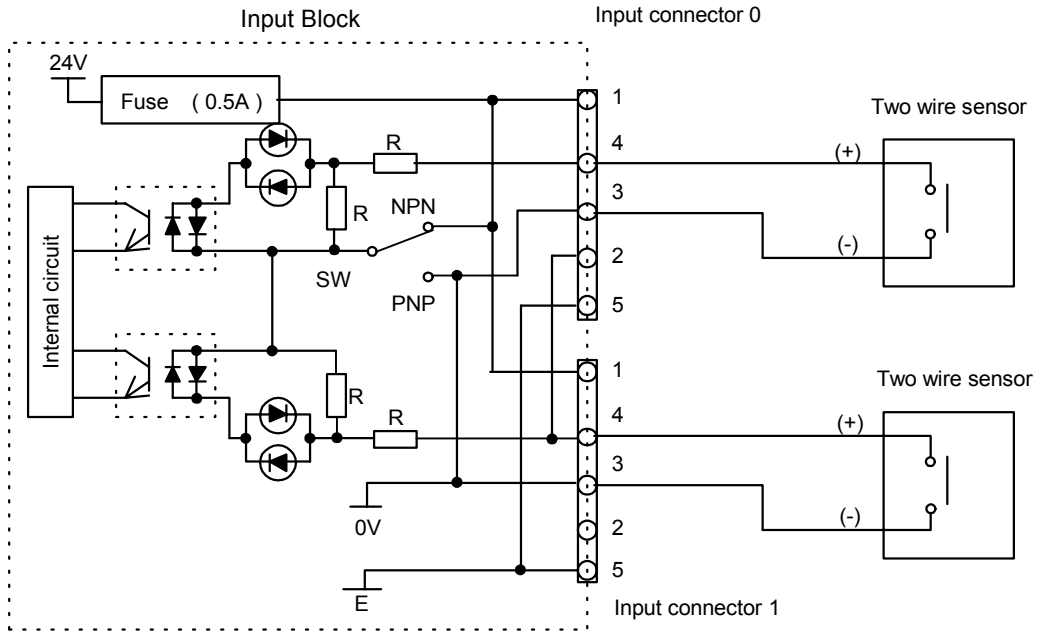

EX250-IE2 input circuit construction

(1) NPN sensor

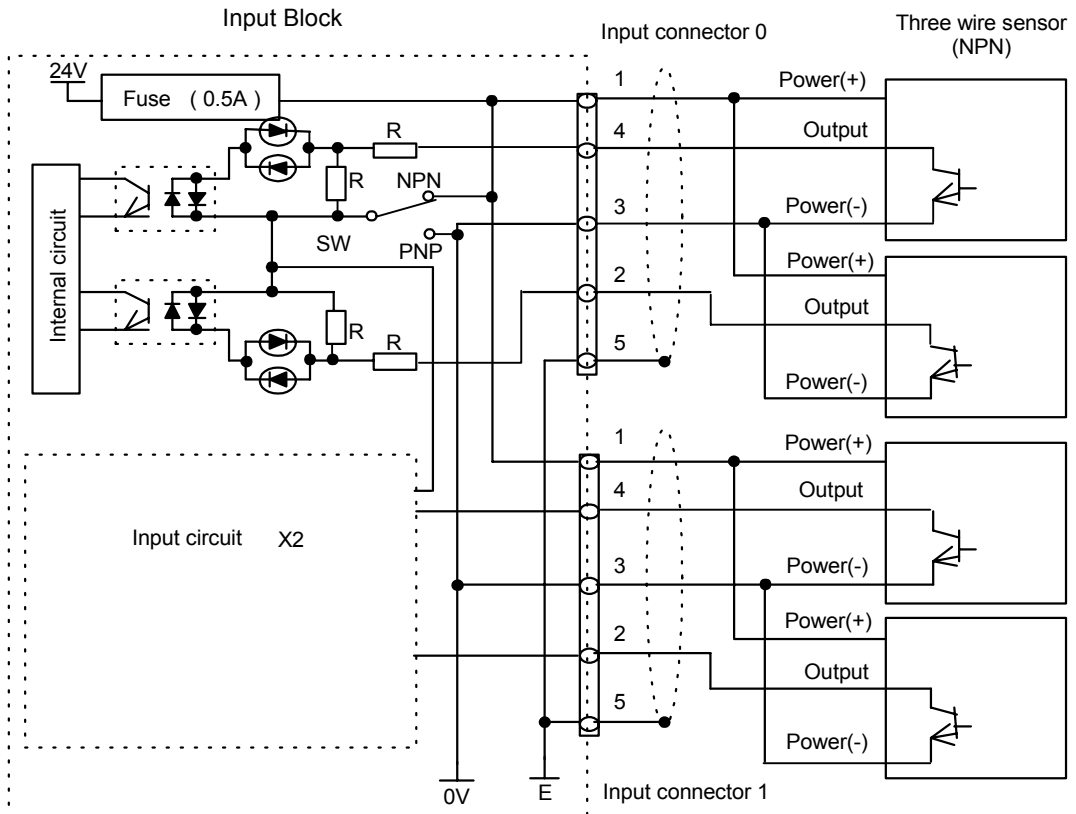

(2) PNP sensor

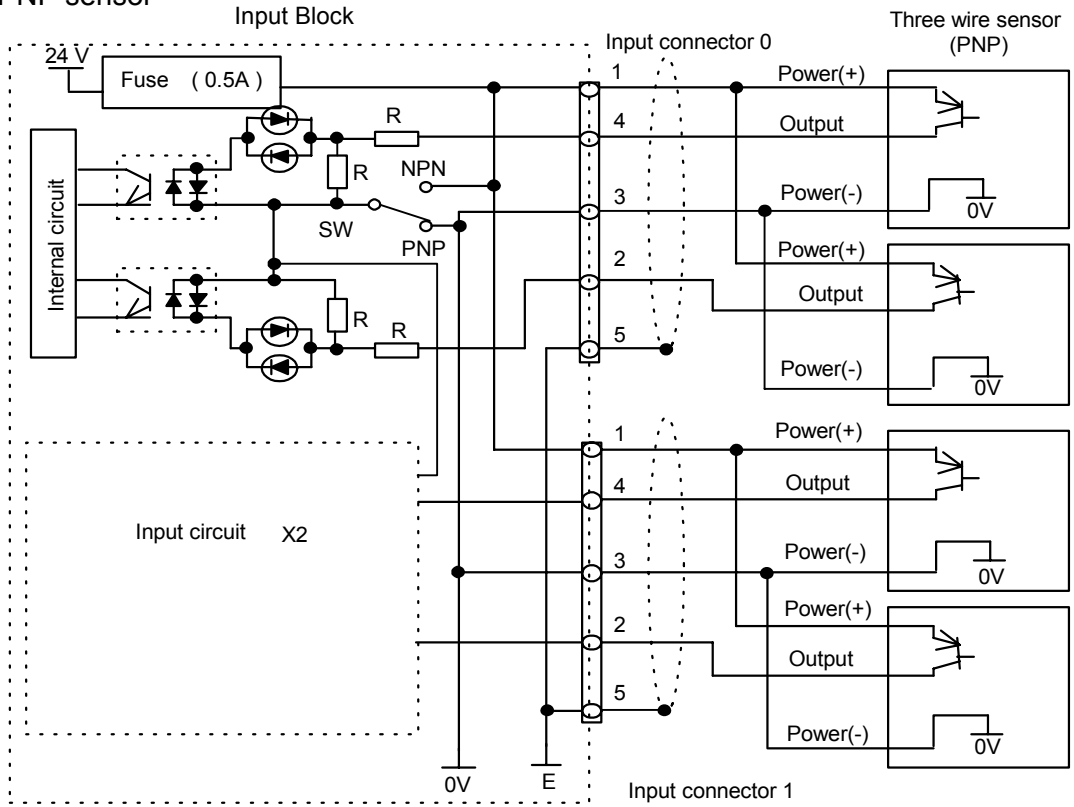

(3) Two wire sensor

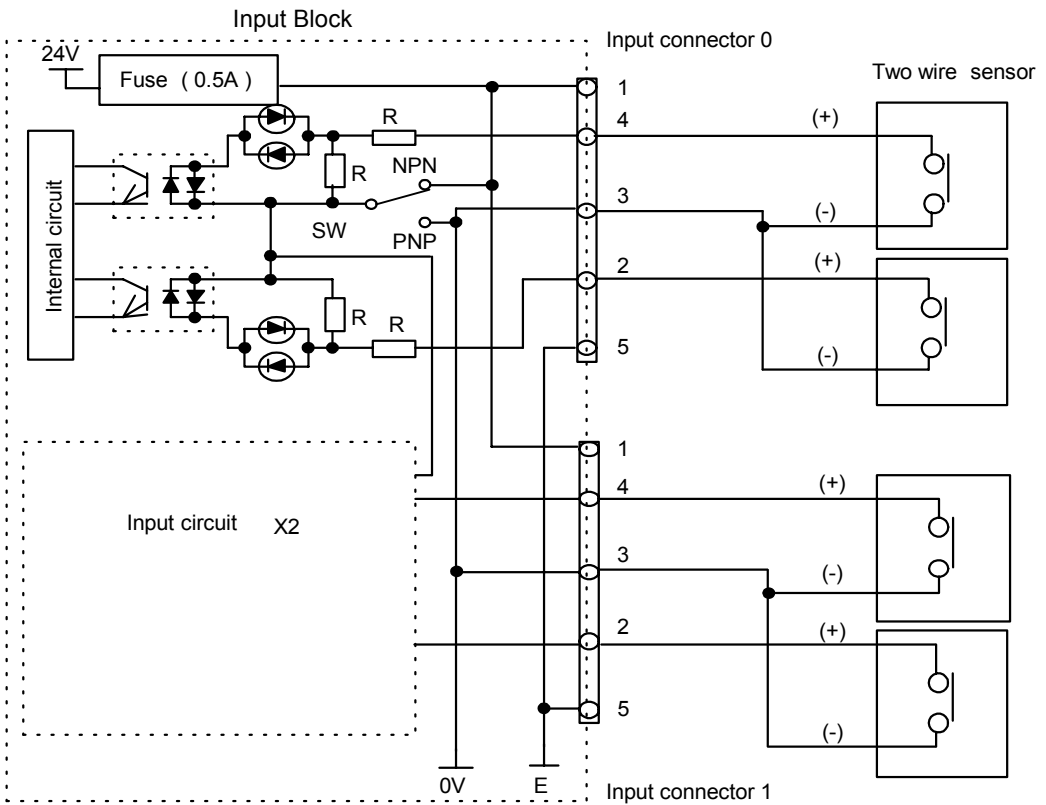

EX250-IE3 input circuit construction

(1) NPN sensor

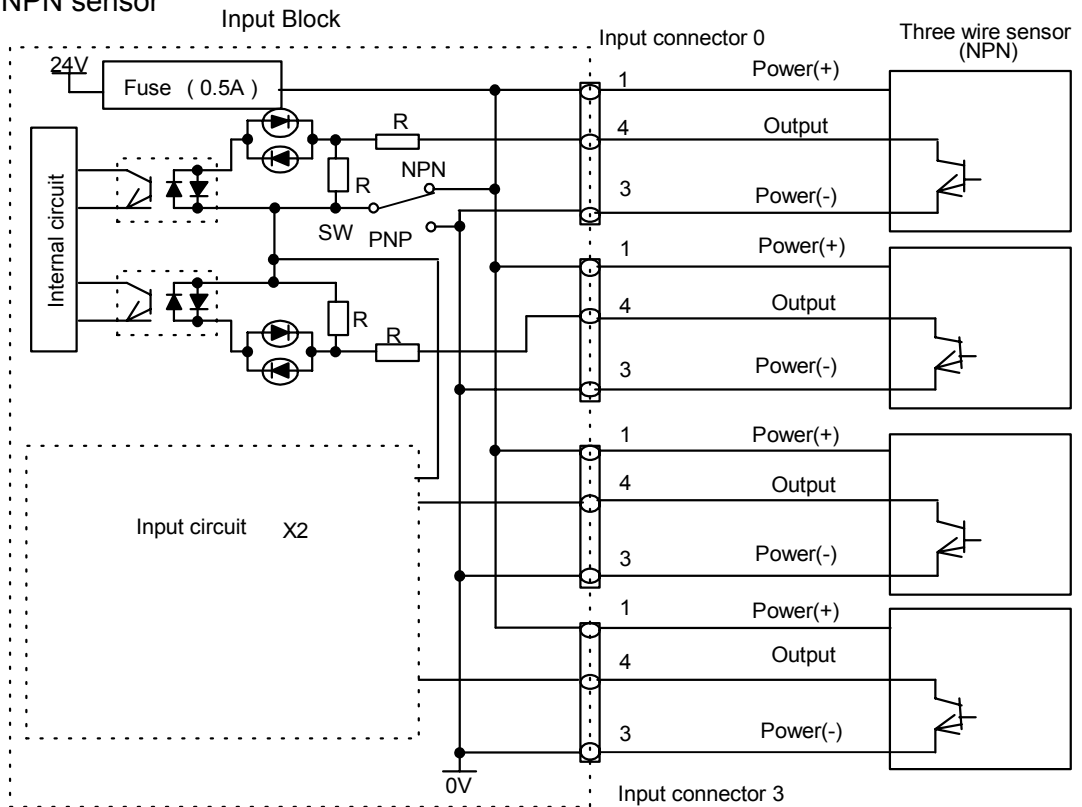

(2) PNP sensor

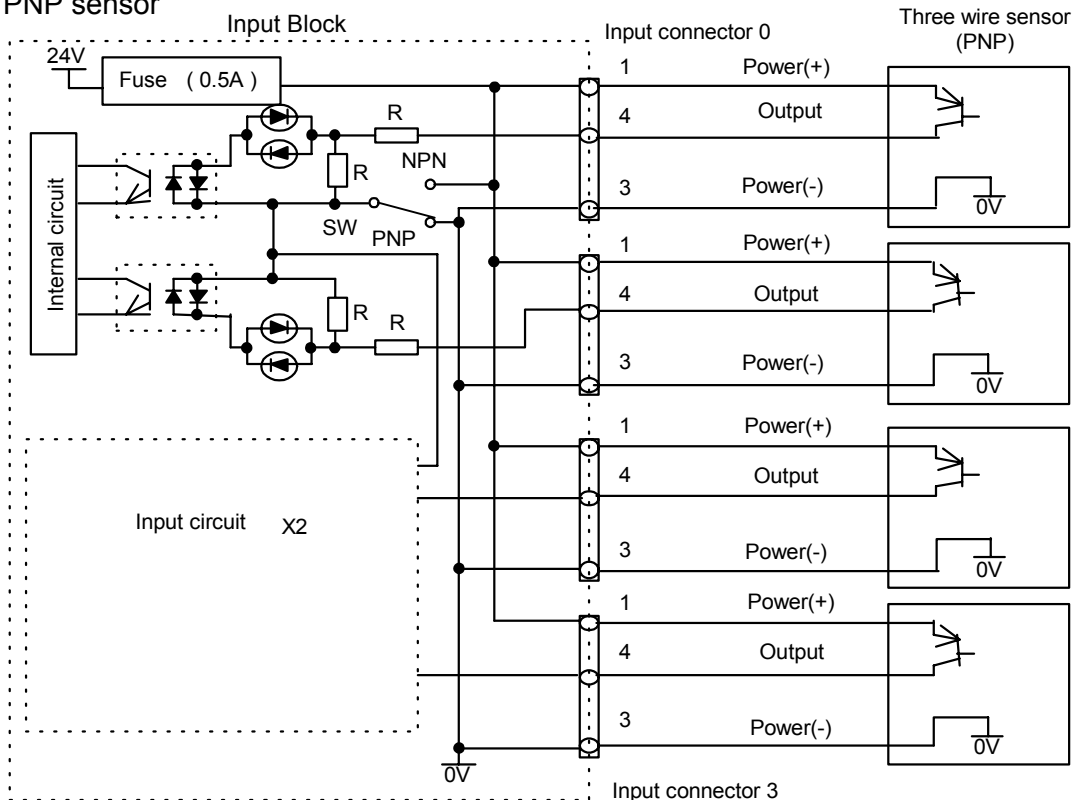

(3) Two wire sensor

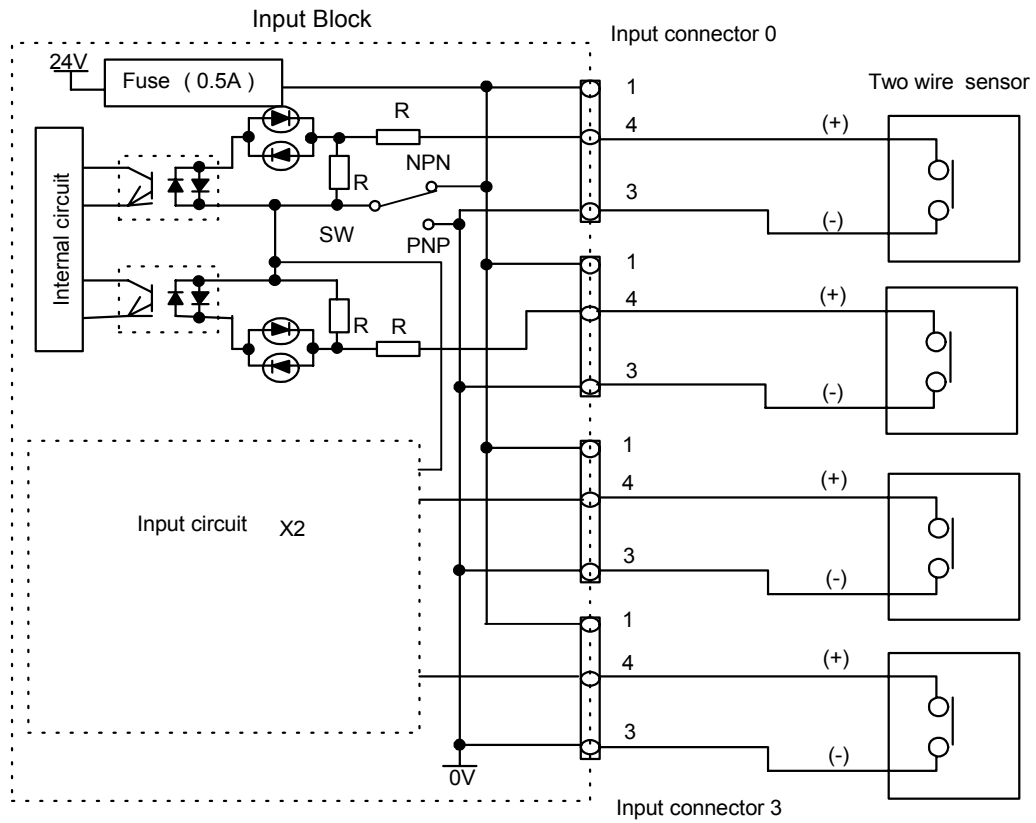

Connecting of sensor

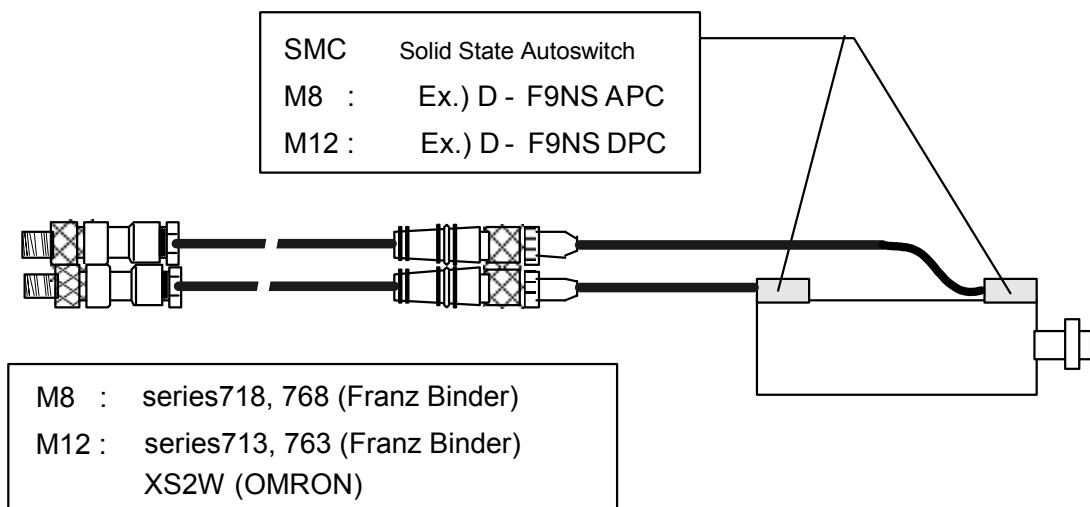

An example of connecting autoswitch and extension cable

Input current

The available current to the sensor is 30mA maximum for each input point.

In power supply for the sensor, if an over current flows because of short circuit etc, power supply will be cut-off by the fuse cutting.

In this case, the user must fix the cause of the short circuit before exchange the fuse.

In changing, release the combination of units and perform by individual Input Block.

Please refer to “3-2 Installation and maintenance” for assembling / disassembling procedure.

Fuse model : LM05 (0.5A) Maker : Daito Communication Co. Ltd.

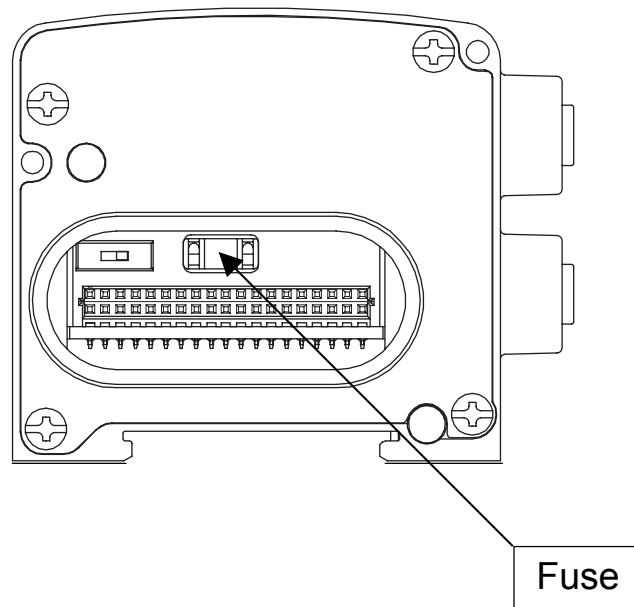

Connector

(1) EX250-IE1 connector

M12 5pin (Female)

Cable side : Ex. OMRON Corp. XS2, XS2W
Franz Binder series713, 763 etc.

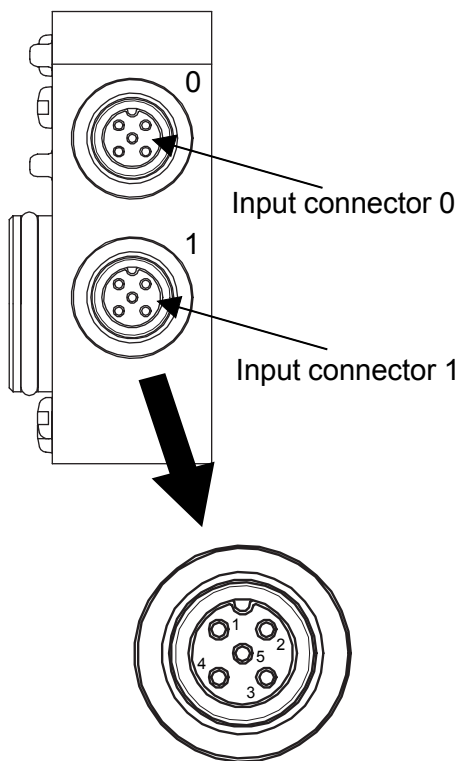

Input connector 0

Pin No.	Description	Function
1	24V	Sensor supply power+
2	IN1	Sensor 1 input signal
3	0V	Sensor supply power-
4	IN0	Sensor 0 input signal
5	E	Earth

Input connector 1

Pin No.	Description	Function
1	24V	Sensor supply power+
2	—	Unused
3	0V	Sensor supply power-
4	IN1	Sensor 1 input signal
5	E	Earth

Pin No.2 of Input connector 0 and Pin No.4 of Input connector 1 are connected inside the Input Block.

This enables the user to use two different inputs by using a single Input connector 0 and reduces the cost of wiring.

To ensure the IP67 rating, please use a water proof plug on unused Input connector 1.

The plug part number is XS2Z-12 made by Omron Corp.

(2) EX250-IE2 connector

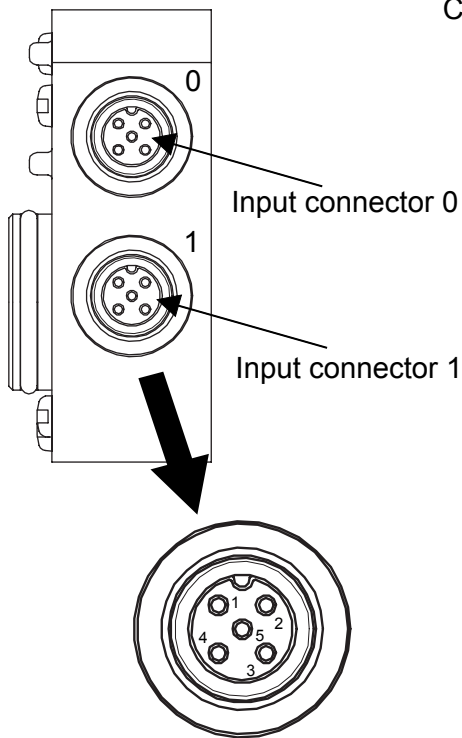

M12 5pin (Female)

Cable side : Ex. OMRON Corp. XS2, XS2W
 Franz Binder series713, 763 etc.

Input connector 0

Pin No.	Description	Function
1	24V	Sensor supply power+
2	IN1	Sensor 1 input signal
3	0V	Sensor supply power-
4	IN0	Sensor 0 input signal
5	E	Earth

Input connector 1

Pin No.	Description	Function
1	24V	Sensor supply power+
2	IN3	Sensor 3 input signal
3	0V	Sensor supply power-
4	IN2	Sensor 2 input signal
5	E	Earth

To ensure the IP67 rating, please use a water proof plug on unused Input connector. Plug part number is XS2Z-12 made by Omron Corp.

(3) EX250-IE3 connector

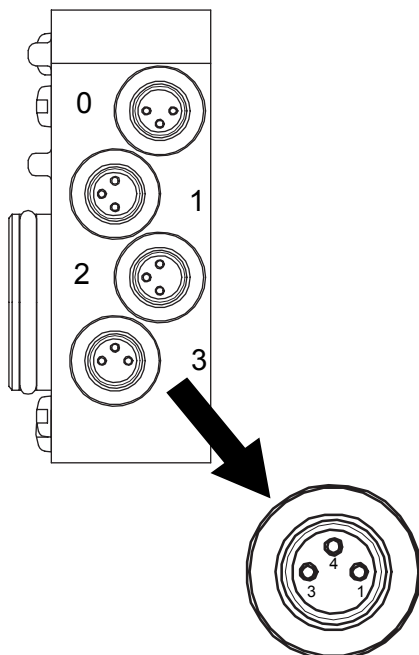

M8 3pin (Female)

Cable side : Ex. Franz Binder series718, 768 etc.

Input connector 0, 1, 2, 3

Pin No.	Description	Function
1	24V	Sensor supply power+
4	IN	Sensor input signal
3	0V	Sensor supply power-

To ensure the IP67 rating, please use a water proof plug on unused Input connector. Plug part number is EX500-AWES made by SMC.

3-2 Installation and maintenance (EX250-IE1,2,3)

Installation size

SI unit does not have mounting holes.

The unit can not be installed by itself.

Solenoid valve manifold must be attached with SI unit.

If no Input Block is required, then the End Plate must be attached with SI unit.

Example of installation

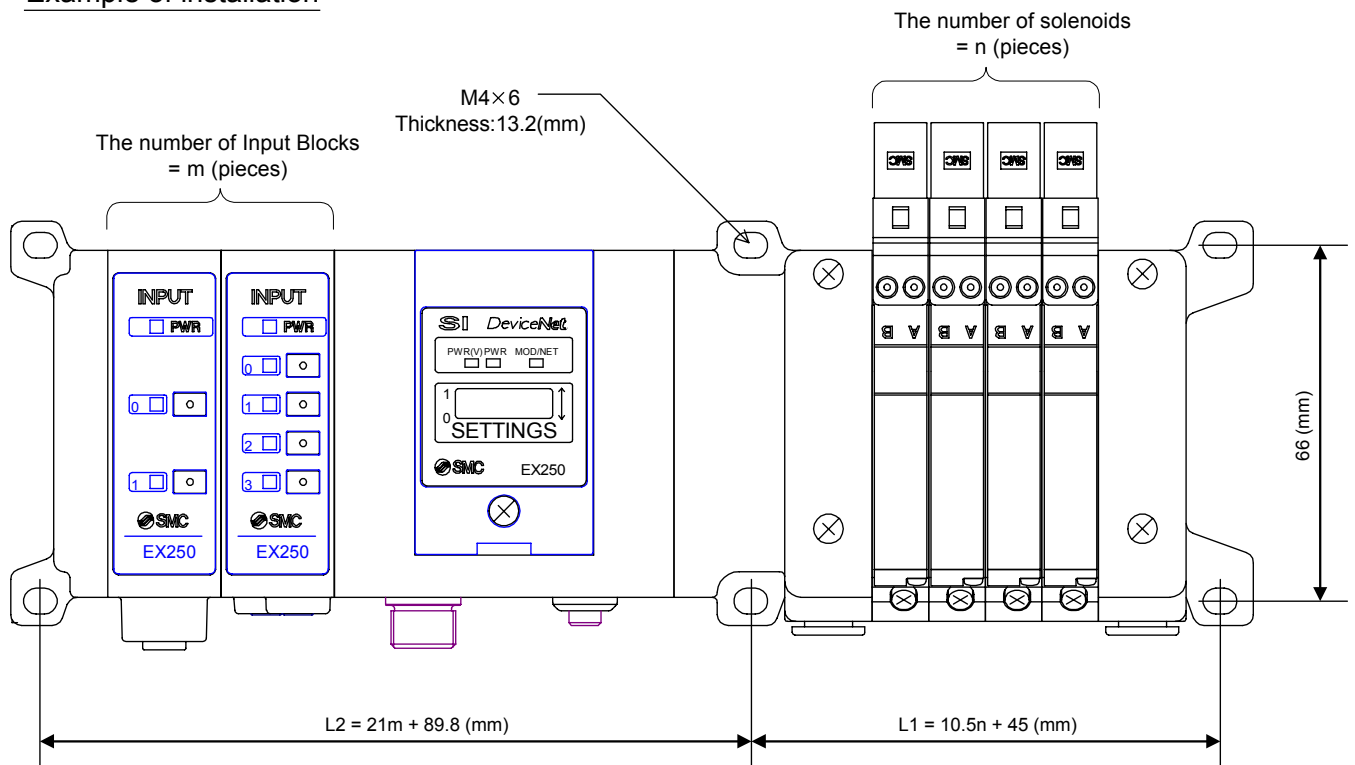

n_m	0	1	2	3	4	5	6	7	8	9	10	11	12	13	14	15	16
L1	45.0	55.5	66.0	76.5	87.0	97.5	108.0	118.5	129.0	139.5	150.0	160.5	171.0	181.5	192.0	202.5	213.0
L2	89.8	110.8	131.8	152.8	173.8	194.8	215.8	236.8	257.8	278.8	299.8	320.8	341.8	362.8	383.8	404.8	425.8

Note : Dimensions of L1 are shown for VQC1000 solenoid valve series.

(mm)

Refer to SMC catalogue for valve series.

Electrical wiring and pneumatic piping has been done from one side only ,to save space for installation or mounting .

Maintenance

Please be sure to turn off the power supply when performing the following operations.

- Addition of Input Block
 - 1.Remove screws from End Plate.
 - 2.Mount attached tie rod.
 - 3.Connect additional Input Block.
 - 4.Connect End Plate and tighten removed screws by specified tightening torque. (0.6N · m)

- Exchange of Input Block
 - 1.Remove screws from End Plate and release connection of each unit.
 - 2.Replace old Input Block with new one. (Tie rod does not need to be removed.)
 - 3.Connect End Plate and tighten removed screws by specified tightening torque. (0.6N · m)

Caution for maintenance

- (1) Be sure to turn-off all power supplies.
- (2) Be sure that there is no foreign object in any of units.
- (3) Be sure that gasket is lined properly.
- (4) Be sure that tightening torque is according to specification.

If these items are not kept, it may lead to the breakage of substrate or intrusion of liquid or dust into the units.

Assembly and disconnection of unit

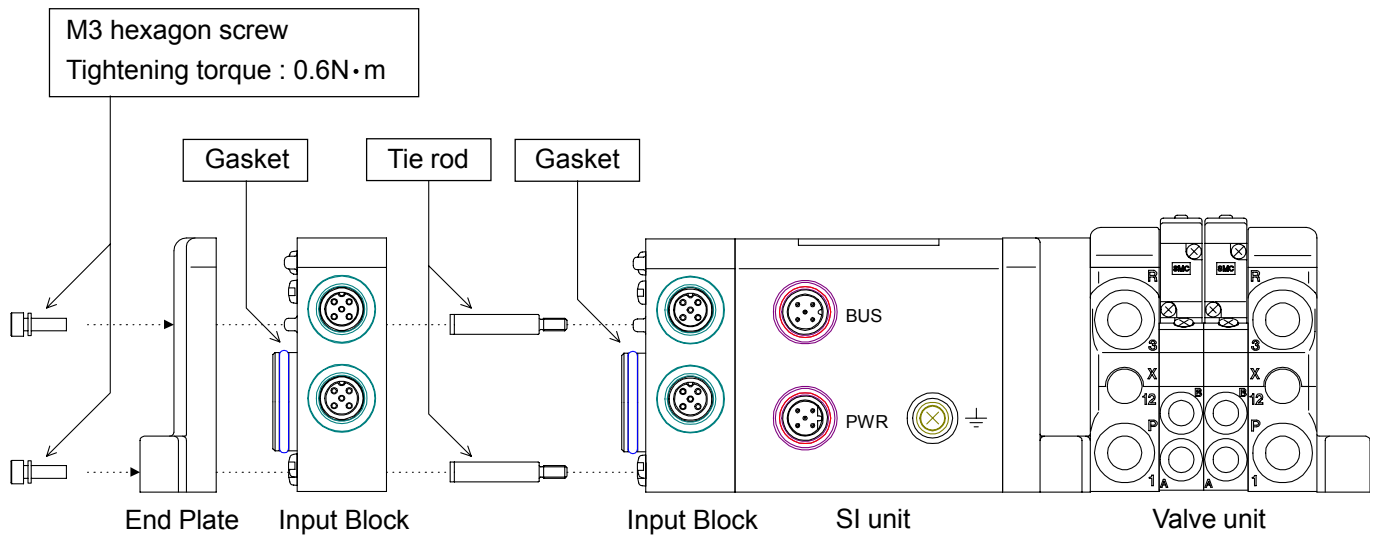

3-3 Input selector switch

Setting for the sensor input is “PNP” when units are shipped from the factory.

In case of connecting NPN sensor, please change the setting from PNP to NPN by selector switch as shown the picture below.

Input manifold must be dis-assembled into individual Input Blocks to change the switch position. Please refer to “3-2. Installation and maintenance” for assembling / disassembling procedure.

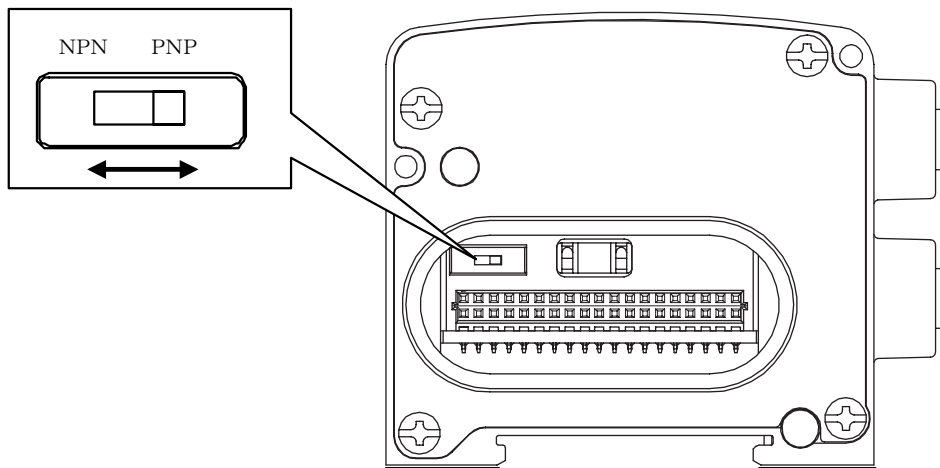

4.LED indicator and Physical dimensions

4-1 LED indication

Input Block (EX250-IE1)

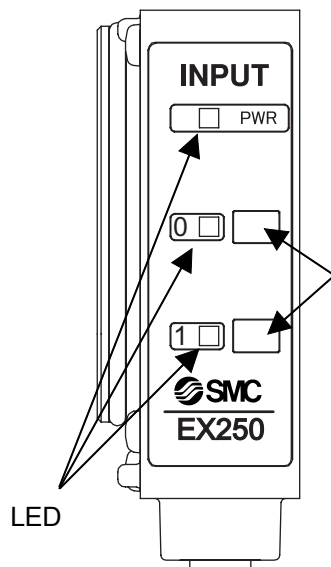

User's nameplate

Indication	Contents
PWR (Green)	Lights when input power is on.
0 (Yellow)	Lights up when sensor 0 input signal is on.
1 (Yellow)	Lights up when sensor 1 input signal is on.

Input Block (EX250-IE2,3)

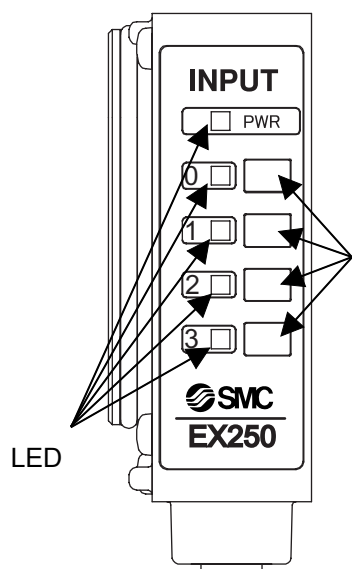

Indication	Contents
PWR (Green)	Lights when input power is on.
0 (Yellow)	Lights up when sensor 0 input signal is on.
1 (Yellow)	Lights up when sensor 1 input signal is on.
2 (Yellow)	Lights up when sensor 2 input signal is on.
3 (Yellow)	Lights up when sensor 3 input signal is on.

User's nameplate

4-2 Physical dimensions

Input Block (EX250-IE1)

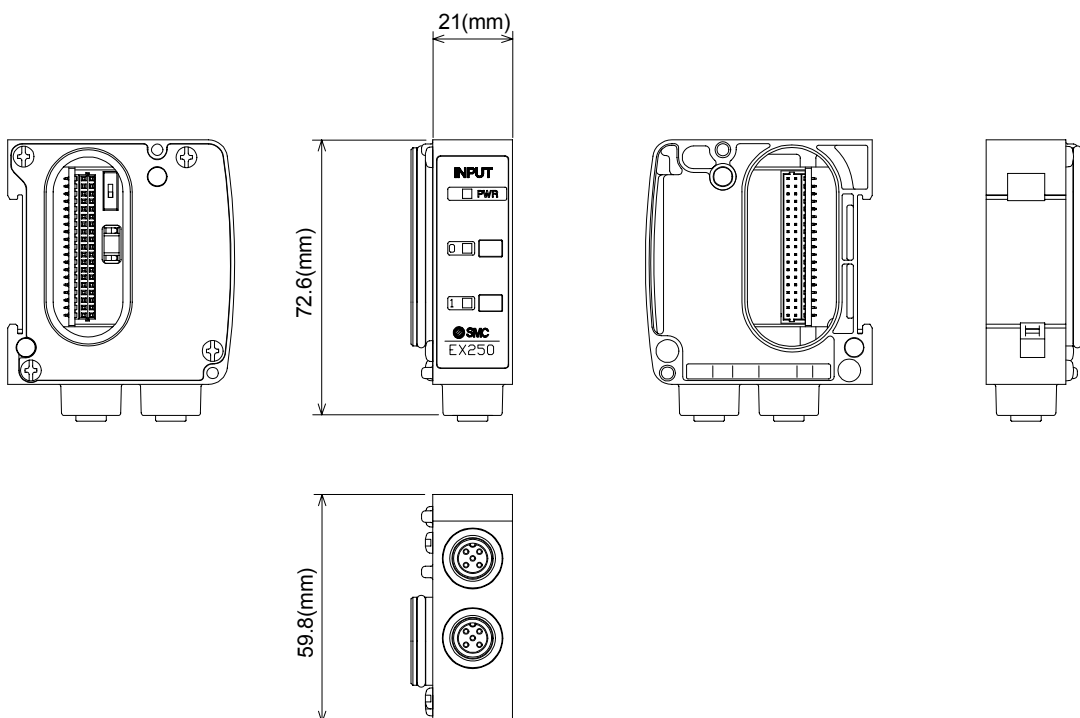

Input Block (EX250-IE2)

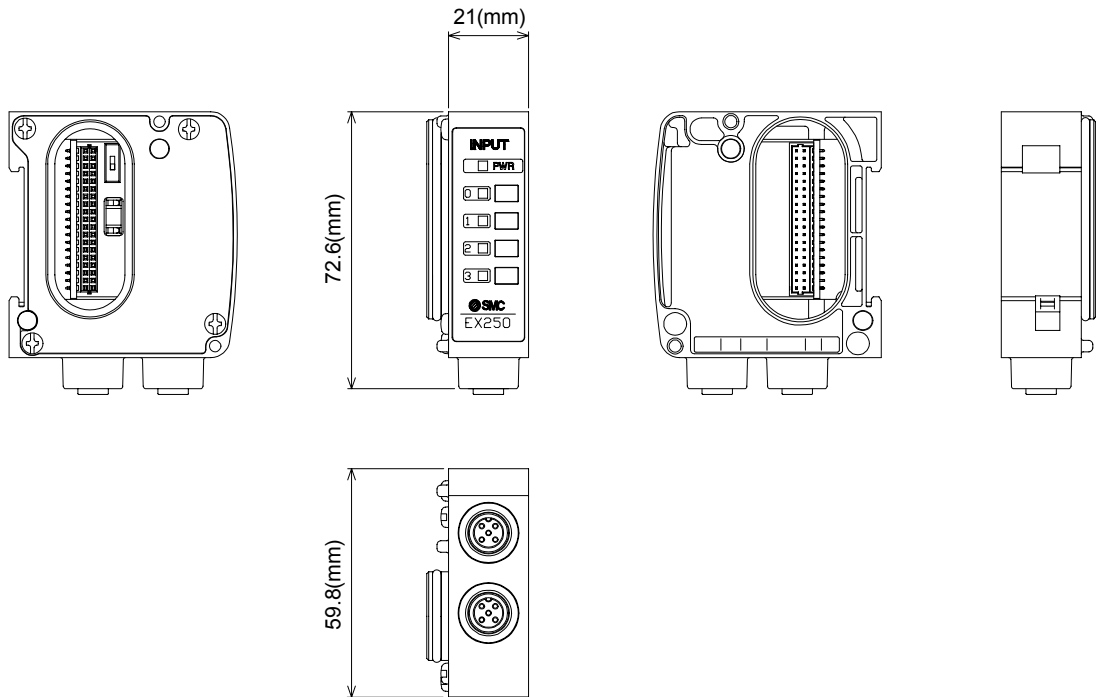

Input Block (EX250-IE3)

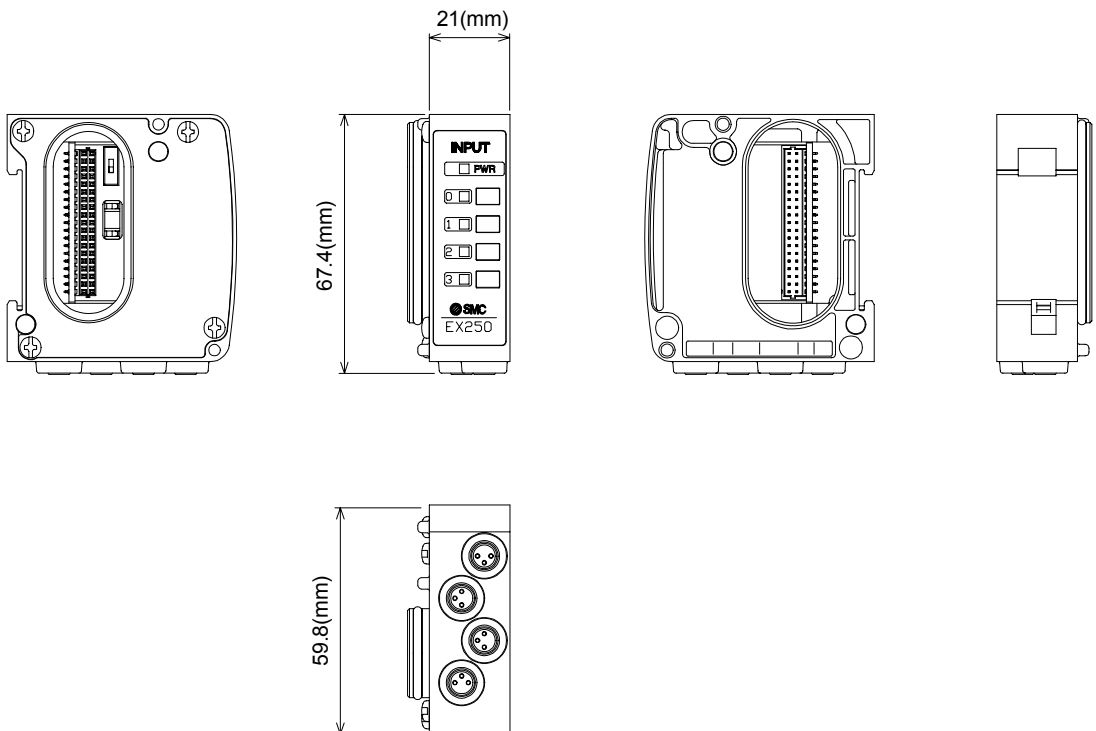

5. Trouble Shooting

PWR LED	Power ON / OFF LED
Green lights off Pale green lights up	<Countermeasures> <ul style="list-style-type: none">• Confirm fuse breakage of Input Block.• Confirm input power (24V) of SI unit.• Exchange SI unit.• Exchange Input Block.
0 to 3 LED	Input signal ON / OFF LED
No lights up No lights off	<Countermeasures> <ul style="list-style-type: none">• Confirm connector connecting.• Confirm the kind of sensors (PNP / NPN).• Confirm after reversing the sensors.• Exchange Input Block.